

# Quick-Lift Rail

## QL R 125i

Intelligent lifting device which meets the highest standards of ergonomics, working **environment, safety and efficiency.**

Easy to use, thanks to outstanding responsiveness, regardless of load weight.

Exceptional safety is achieved using our intelligent control systems.

The best auto balancing available, regardless of load weight.

High cost efficiency through low power consumption, high reliability and long durability.



Distributed By



McLaughlin Hoist & Crane

(636)343-9700

[www.stlcrane.com](http://www.stlcrane.com)

[Sales@StLCrane.com](mailto:Sales@StLCrane.com)

# BINAR

*Improving your productivity*

# Quick-Lift Rail

## QL R 125i

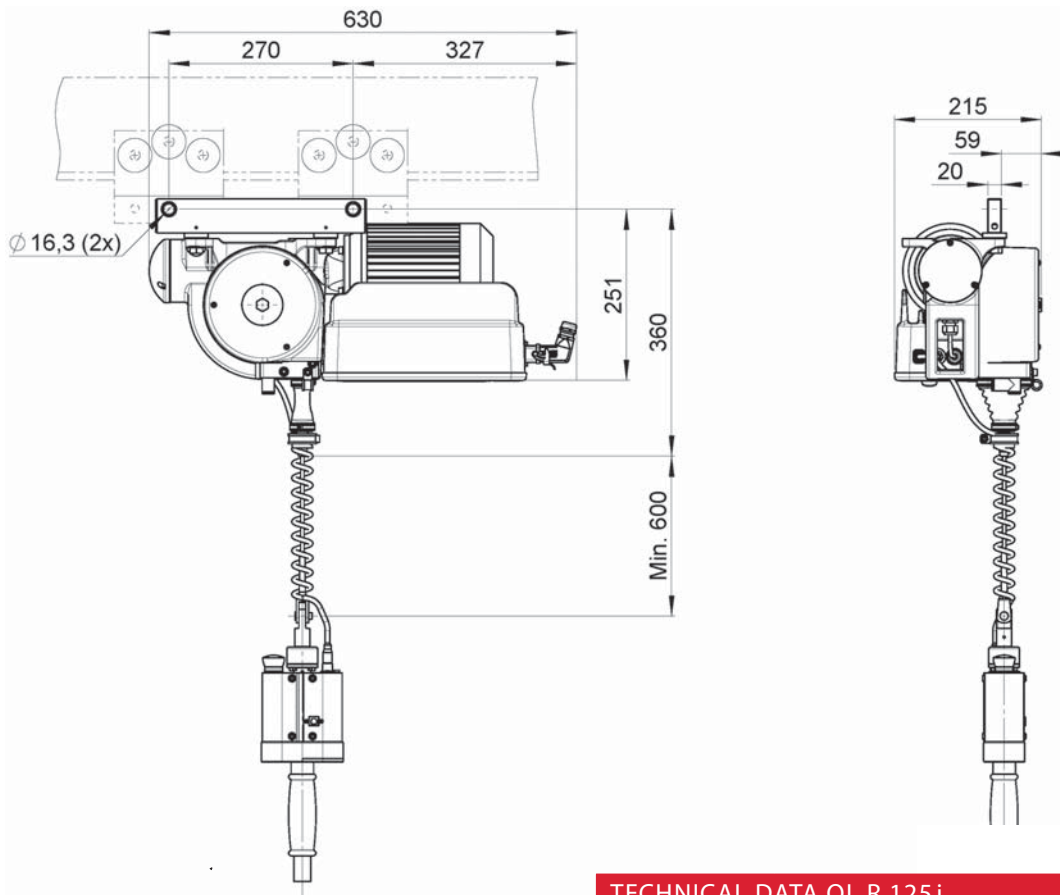

### TECHNICAL DATA QL R 125 i

Lifting capacity	Max 125 kg
Lift motor	Stepless servo-controlled asynchronous motor
Weight	28 kg
Manoeuvring	<p>Manoeuvring is done by using a patented manoeuvring handle or balancing mode. Both options sense the operator's hand/arm movement and give a very exact and smooth speed control.</p> <p>Only a force equivalent to 20 gram is needed to engage the up/down motion. When the operator let go of the handle or object, the up/down motion is immediately stopped.</p>
Power supply	230V, 50-60 Hz, 1-phase with ground protection, 10A
Stroke length	2,7 meter
Suspension	The QL R 125i can be mounted in the most types of rail systems. Existing rail systems can often be used.
Gripping device	<p>Grippers are designed to fit customer's need. Intelligent I/O signals are available for optimum functionality.</p> <p>Easy accessible USB communication as standard.</p>

Binar Quick-Lift Systems AB disclaims responsibility for any errors or incomplete information in the published material and reserves the right to make changes.

Binar Quick-Lift Systems AB

Distributed by:

McLaughlin Hoist & Crane

Sales@StLCrane.com or (636) 343-9700

2010-11-16 eng 1.02

# BINAR

*Improving your productivity*