

**CHESTER**  
**HOIST**

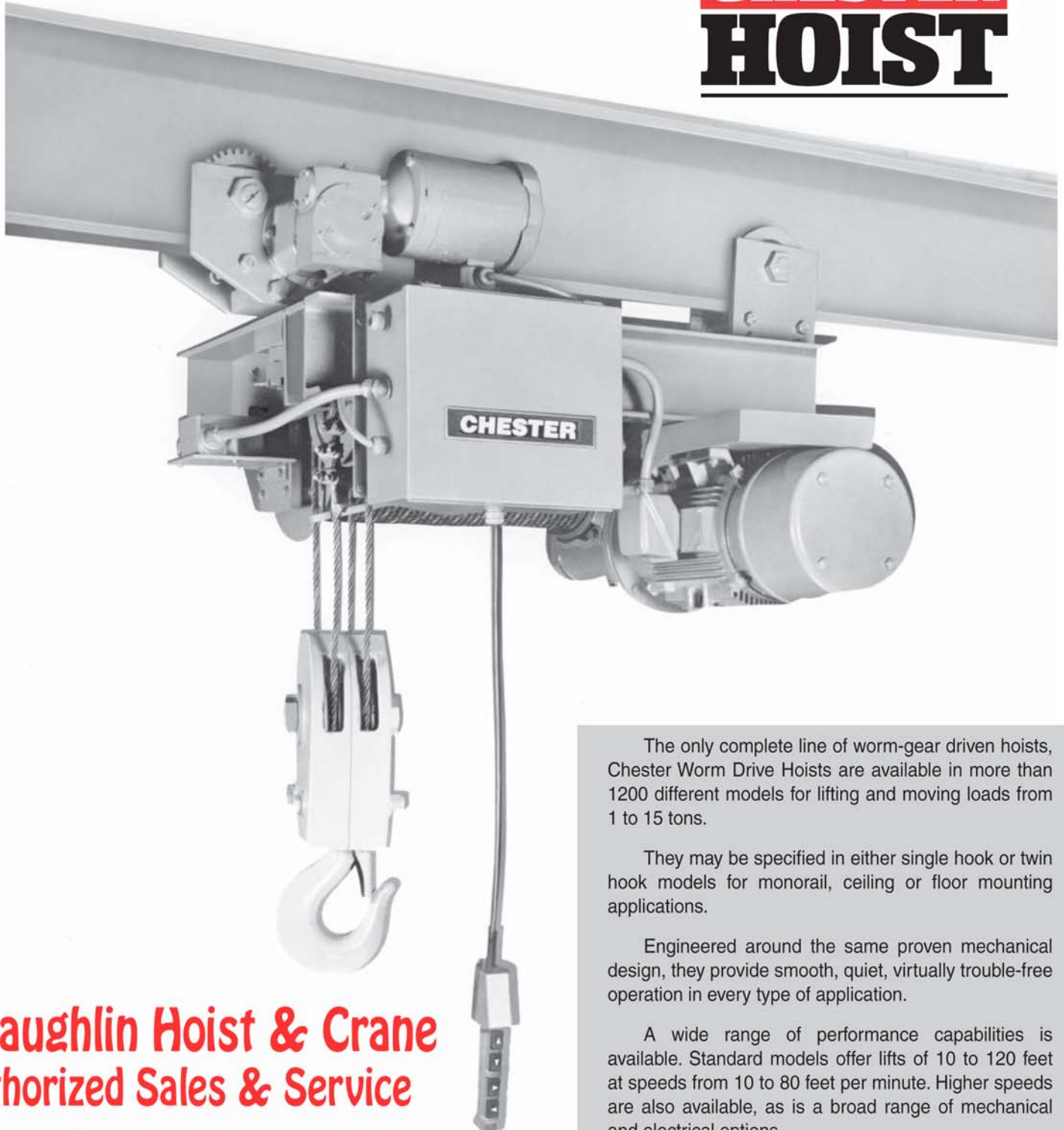

The only complete line of worm-gear driven hoists, Chester Worm Drive Hoists are available in more than 1200 different models for lifting and moving loads from 1 to 15 tons.

They may be specified in either single hook or twin hook models for monorail, ceiling or floor mounting applications.

Engineered around the same proven mechanical design, they provide smooth, quiet, virtually trouble-free operation in every type of application.

A wide range of performance capabilities is available. Standard models offer lifts of 10 to 120 feet at speeds from 10 to 80 feet per minute. Higher speeds are also available, as is a broad range of mechanical and electrical options.

**McLaughlin Hoist & Crane**  
**Authorized Sales & Service**

**(636) 343-9700**

**[www.stlcrane.com](http://www.stlcrane.com)**

# SPECIFICATIONS & CLEARANCE DIMENSIONS

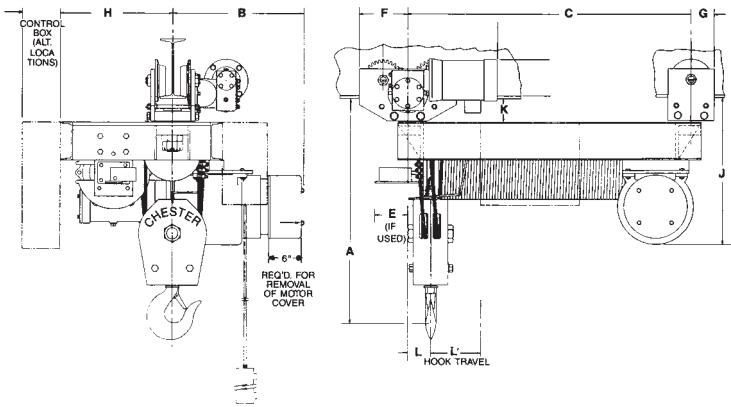

FOR CHESTER  
WORM DRIVE HOIST

TYPE	CAPACITY LBS.	SPEED (fpm)	MOTOR (hp)	LIFT (ft)	MODEL NUMBER	A	B	C	E	F	G	H	J	K	L	L'	WGT.	REEVING		
R	2,000	20	2 @ 1200	24	WDMT-127	22	20 <sup>1</sup> / <sub>2</sub>	21 <sup>1</sup> / <sub>2</sub>	5 <sup>1</sup> / <sub>2</sub>	7 <sup>3</sup> / <sub>8</sub>	3 <sup>1</sup> / <sub>2</sub>	16	20 <sup>3</sup> / <sub>4</sub>	4	4	4 <sup>1</sup> / <sub>4</sub>	640	2PS-1/4		
				45	WDMT-128		28												7 <sup>1</sup> / <sub>2</sub>	690
				66	WDMT-129		34 <sup>1</sup> / <sub>2</sub>												11	740
				98	WDMT-129B		44 <sup>1</sup> / <sub>2</sub>												16	820
		24	WDMT-120		21 <sup>1</sup> / <sub>2</sub>											4 <sup>1</sup> / <sub>4</sub>	640			
		45	WDMT-121		28											7 <sup>1</sup> / <sub>2</sub>	690			
		66	WDMT-122		34 <sup>1</sup> / <sub>2</sub>											11	740			
		98	WDMT-122B		44 <sup>1</sup> / <sub>2</sub>											16	820			
		24	WDMT-123		21 <sup>1</sup> / <sub>2</sub>											4 <sup>1</sup> / <sub>4</sub>	640			
		45	WDMT-124		28											7 <sup>1</sup> / <sub>2</sub>	690			
		68	WDMT-125		34 <sup>1</sup> / <sub>2</sub>											11	740			
		98	WDMT-125B	22	44 <sup>1</sup> / <sub>2</sub>											16	820			
	18	WDMT-130	25 <sup>1</sup> / <sub>2</sub>	21 <sup>1</sup> / <sub>2</sub>											4 <sup>1</sup> / <sub>4</sub>	640	2PS-5/16			
	35	WDMT-131		28											7 <sup>1</sup> / <sub>2</sub>	690				
	52	WDMT-132		34 <sup>1</sup> / <sub>2</sub>											11	740				
	18	WDMT-133		21 <sup>1</sup> / <sub>2</sub>											4 <sup>1</sup> / <sub>4</sub>	640				
	35	WDMT-134		28											7 <sup>1</sup> / <sub>2</sub>	690				
	52	WDMT-135	20 <sup>1</sup> / <sub>2</sub>	34 <sup>1</sup> / <sub>2</sub>											11	740				
	18	WDMT-136	23 <sup>1</sup> / <sub>2</sub>	21 <sup>1</sup> / <sub>2</sub>								16	20 <sup>3</sup> / <sub>4</sub>		4 <sup>1</sup> / <sub>4</sub>	665	4PS-1/4			
	35	WDMT-137		28											7 <sup>1</sup> / <sub>2</sub>	715				
	52	WDMT-138	25 <sup>1</sup> / <sub>2</sub>	23 <sup>1</sup> / <sub>2</sub>	34 <sup>1</sup> / <sub>2</sub>							16	20 <sup>3</sup> / <sub>4</sub>		11	765				
	12	WDMT-146	28	20 <sup>1</sup> / <sub>2</sub>	21 <sup>1</sup> / <sub>2</sub>							16 <sup>1</sup> / <sub>4</sub>	22 <sup>3</sup> / <sub>4</sub>		2 <sup>1</sup> / <sub>4</sub>	760				
	22	WDMT-147		28											3 <sup>3</sup> / <sub>4</sub>	810				
	32	WDMT-148		34 <sup>1</sup> / <sub>2</sub>											5 <sup>3</sup> / <sub>8</sub>	860				
49	WDMT-148A		44 <sup>1</sup> / <sub>2</sub>											8	960	4PS-1/4				
72	WDMT-148B		58 <sup>1</sup> / <sub>2</sub>											11 <sup>1</sup> / <sub>2</sub>	1060					
93	WDMT-148C		71 <sup>1</sup> / <sub>2</sub>											15	1160					
115	WDMT-148D		85 <sup>1</sup> / <sub>2</sub>											18 <sup>1</sup> / <sub>2</sub>	1260					
12	WDMT-140		21 <sup>1</sup> / <sub>2</sub>											2 <sup>1</sup> / <sub>4</sub>	760					
22	WDMT-141		28											3 <sup>3</sup> / <sub>4</sub>	810					
32	WDMT-142		34 <sup>1</sup> / <sub>2</sub>											5 <sup>3</sup> / <sub>8</sub>	860	2PS-3/8				
49	WDMT-142A		44 <sup>1</sup> / <sub>2</sub>											8	910					
72	WDMT-142B		58 <sup>1</sup> / <sub>2</sub>											11 <sup>1</sup> / <sub>2</sub>	1010					
93	WDMT-142C		71 <sup>1</sup> / <sub>2</sub>											15	1110					
115	WDMT-142D	28	20 <sup>1</sup> / <sub>2</sub>	85 <sup>1</sup> / <sub>2</sub>	5 <sup>1</sup> / <sub>2</sub>						16 <sup>1</sup> / <sub>4</sub>	22 <sup>3</sup> / <sub>4</sub>		18 <sup>1</sup> / <sub>2</sub>	1210					
20	WDMT-143	32	22	26 <sup>1</sup> / <sub>8</sub>	5 <sup>1</sup> / <sub>4</sub>						17 <sup>3</sup> / <sub>4</sub>	23 <sup>3</sup> / <sub>8</sub>	4	4	5 <sup>3</sup> / <sub>4</sub>		890			
40	WDMT-144			34 <sup>7</sup> / <sub>8</sub>											10 <sup>1</sup> / <sub>8</sub>	940	2PS-3/8			
60	WDMT-145			43 <sup>5</sup> / <sub>8</sub>											14 <sup>1</sup> / <sub>2</sub>	990				
75	WDMT-145A			43 <sup>5</sup> / <sub>8</sub>											14 <sup>1</sup> / <sub>2</sub>	1010				
90	WDMT-145B			43 <sup>5</sup> / <sub>8</sub>											14 <sup>1</sup> / <sub>2</sub>	1015				
120	WDMT-145C	32	22	53 <sup>5</sup> / <sub>8</sub>	5 <sup>1</sup> / <sub>4</sub>						17 <sup>3</sup> / <sub>4</sub>	23 <sup>3</sup> / <sub>8</sub>			19 <sup>1</sup> / <sub>2</sub>	1050	2PS-5/16E			
9	WDMT-160	28	20 <sup>1</sup> / <sub>2</sub>	21 <sup>1</sup> / <sub>2</sub>	5 <sup>1</sup> / <sub>2</sub>						16 <sup>1</sup> / <sub>4</sub>	22 <sup>3</sup> / <sub>4</sub>			2 <sup>1</sup> / <sub>4</sub>	760	4PS-5/16			
17	WDMT-161			28											3 <sup>3</sup> / <sub>4</sub>	810				
26	WDMT-162			34 <sup>1</sup> / <sub>2</sub>											5 <sup>3</sup> / <sub>8</sub>	860				
39	WDMT-162A			44 <sup>1</sup> / <sub>2</sub>											8	850				
57	WDMT-162B			58 <sup>1</sup> / <sub>2</sub>											11 <sup>1</sup> / <sub>2</sub>	950				
74	WDMT-162C	28	20 <sup>1</sup> / <sub>2</sub>	71 <sup>1</sup> / <sub>2</sub>	5 <sup>1</sup> / <sub>2</sub>	7 <sup>3</sup> / <sub>8</sub>	3 <sup>1</sup> / <sub>2</sub>	16 <sup>1</sup> / <sub>4</sub>	22 <sup>3</sup> / <sub>4</sub>	4	4	15	1050							

**NOTE:** When adding a geared limit switch — add 1" to head room "A" dimension.  
**NOTE:** All Hoists with a lift exceeding 60' include a geared limit switch.

**NOTE:** TVL – (True Vertical Lift).

# MOTORIZED TROLLEY SUSPENSION



The Chester side-drive motorized trolley increases speed and efficiency of load handling. Worm gearing in all sizes of motorized trolleys assists in smooth acceleration and deceleration.

With a motorized trolley suspension, a Chester Worm Drive Hoist can lift and transport loads to 15 tons with push button ease.

Multiple motorized trolleys are normally used for larger hoists (consult factory).

Trolleys can be supplied for I-beam, wide-flange or patented track systems. Specify flange width — from 3 1/4" to 8". Trolleys for wider flanges are available at extra cost. Each trolley is made for the specified beam or track, and is not adjustable to other sizes.

Standard trolley speeds available: 15, 20, 35, 50, 75, 100, 150 fpm.

CAPACITY TONS	SIZE	CLEARANCE	MIN. CURVE RADIUS
1 - 5	7 - 24	7/16	6 ft.
6 - 7 1/2 (4PS) Reeving	8 - 24	5/8	6 ft.
7 1/2 (2PD) Reeving	7 - 24	7/16	6 ft.
10 - 15	8 - 24	5/8	7 ft.

TYPE	CAPACITY LBS.	SPEED (fpm)	MOTOR (hp)	LIFT (ft)	MODEL NUMBER	A	B	C	E	F	G	H	J	K	L	L'	WGT.	REEVING	
R	6,000	20	6 @ 1800	9	WDMT-163	28	23 1/2	21 1/2	5 1/2	7 3/8	3 1/2	16 1/4	22 3/4	4	4	2 1/4	800	4PS-5/16	
				17	WDMT-164			28									3 3/4		850
				26	WDMT-165			34 1/4									5 3/8		900
				39	WDMT-165A			44 1/2									8		1035
				57	WDMT-165B			58 1/2									11 1/2		1135
			74	WDMT-165C	28	23 1/2	71 1/2	5 1/2						16 1/4	22 3/4		15	1235	2PS-7/16
			20	WDMT-166	32	22	26 1/8	5 1/4						17 3/4	23 3/8		5 3/4	890	
			40	WDMT-167			34 7/8										10 1/8	940	
			60	WDMT-168			43 5/8										14 1/2	990	
			80	WDMT-168A	32		53 5/8							17 3/4			19 1/2	1050	
S	8,000	15	6 @ 1800	10	WDMT-180	36		26 1/8				18 1/4				3	1150	4PS-3/8	
				20	WDMT-181			34 7/8								5 1/4	1200		
				30	WDMT-182			43 5/8								7 1/4	1250		
				38	WDMT-182A			43 5/8								7 1/4	1250		
				50	WDMT-182B			53 5/8								9 1/2	1300		
				75	WDMT-182C			70 5/8								15 1/2	1400		
				100	WDMT-182D			89 1/8								18 1/2	1550		
		10	WDMT-183			26 1/8									3	1150	4PS-3/8		
		20	WDMT-184			34 7/8									5 1/4	1200			
		30	WDMT-185			43 5/8									7 1/4	1250			
		38	WDMT-185A			43 5/8									7 1/4	1250			
		50	WDMT-185B			53 5/8									9 1/2	1300			
		75	WDMT-185C			70 5/8									15 1/2	1400			
		100	WDMT-185D			89 1/8									18 1/2	1550			
T	10,000	10	5 @ 1200	10	WDMT-1100			26 1/8								3	1150	4PS-7/16	
				20	WDMT-1101			34 7/8								5 1/4	1200		
				30	WDMT-1102			43 5/8								7 1/4	1250		
				38	WDMT-1102A			43 5/8								7 1/4	1250		
				50	WDMT-1102B			53 5/8								9 1/2	1300		
		75	WDMT-1102C			70 1/8								15 1/2	1400	4PS-3/8E			
		10	WDMT-1103			26 1/8									3		1150		
		20	WDMT-1104			34 7/8									5 1/4		1200		
		30	WDMT-1105			43 5/8									7 1/4		1250		
		38	WDMT-1105A			43 5/8									7 1/4		1250		
		50	WDMT-1105B			53 5/8									9 1/2	1300	4PS-3/8E		
		75	WDMT-1105C	36	22	70 1/8							18 1/4	23 3/8	4	15 1/2		1400	
		23	WDMT-1104W	28	22 3/4	34 7/8							17 5/8	22 3/8	8 3/4	5		1200	
		35	WDMT-1105W			43 5/8										7		1300	
45	WDMT-1105WA	28	22 3/4	53 5/8							17 5/8	22 3/8	8 3/4	10	1400				
T	20	10 @ 1200	10 @ 1200	15	WDMT-1106	34	31	42 1/2				22 1/4	28 1/2		17 1/2	TVL	2200	2PD-7/16	
				25	WDMT-1107			51 1/2								22	2300		
				35	WDMT-1108			57 1/2								25	2400		
				55	WDMT-1108A			72 1/2								32 1/2	2600		
				65	WDMT-1108B			72 1/2								32 1/2	2600		
				95	WDMT-1108C	34	31	93 1/2	5 1/4	7 3/8	3 1/2	22 1/4	28 1/2	4	42 1/2	TVL	2850		

NOTE: "E" after cable diameter indicates Extra Strength Wire Rope.

# HOW TO ORDER A CHESTER WORM DRIVE HOIST

When specifying a Chester Worm Drive Hoist, the following parameters should be considered. Determine the values required, and clearly state them when ordering. The following checklist will be of help:

1. Load weight to be lifted
2. Lift or reach required
3. Lifting speed or speeds
4. Power supply available
5. How often load must be lifted (specify number of starts per cycle, number of cycles per hour, on-time per hour).
6. Operating environment (moisture, corrosive fumes, explosive vapors, temperature, etc.).
7. Beam sizes and weight (to determine trolley wheel specifications).
8. Trolley type (plain, hand-gear, or motorized) and trolley speed.
9. Controls (may be expressed as functions, such as Hoist Up-Down, Trolley Forward-Reverse, etc.).
10. Headroom requirements (Standard or Low, to accommodate specified lift).

### LETTERS USED IN MODEL DESIGNATIONS:

- WD** – Lug-Mounted Worm Drive Hoist
- WDT** – Worm Drive Hoist with Plain Trolley
- WDGT** – Worm Drive Hoist with Hand-Gear Trolley
- WDMT** – Worm Drive Hoist with Motorized Trolley

TYPE	CAPACITY LBS.	SPEED (fpm)	MOTOR (hp)	LIFT (ft)	MODEL NUMBER	A	B	C	E	F	G	H	J	K	L	L'	WGT.	REEVING	
T	10,000	30	15 @ 1800	15	WDMT-1109	34	31	42 <sup>1</sup> / <sub>2</sub>	5 <sup>1</sup> / <sub>4</sub>	7 <sup>3</sup> / <sub>8</sub>	3 <sup>1</sup> / <sub>2</sub>	22 <sup>1</sup> / <sub>4</sub>	28 <sup>1</sup> / <sub>2</sub>	4	17 <sup>1</sup> / <sub>2</sub>	TVL	2200	2PD-7/16	
				25	WDMT-1110			51 <sup>1</sup> / <sub>2</sub>							22		2300		
				35	WDMT-1111			57 <sup>1</sup> / <sub>2</sub>								25			2400
				55	WDMT-1111A			72 <sup>1</sup> / <sub>2</sub>								32 <sup>1</sup> / <sub>2</sub>			2600
				65	WDMT-1111B			72 <sup>1</sup> / <sub>2</sub>								32 <sup>1</sup> / <sub>2</sub>			2600
						95	WDMT-1111C	34	31	93 <sup>1</sup> / <sub>2</sub>				22 <sup>1</sup> / <sub>4</sub>	28 <sup>1</sup> / <sub>2</sub>	42 <sup>1</sup> / <sub>2</sub>	TVL	2850	2PD-3/8E
		33	15 @ 1800	50	WDMT-1001	37	32	44 <sup>1</sup> / <sub>2</sub>					21 <sup>1</sup> / <sub>2</sub>	27		4	13	2300	
				75	WDMT-1002			57 <sup>1</sup> / <sub>2</sub>									19 <sup>1</sup> / <sub>2</sub>	2450	
				100	WDMT-1003			69 <sup>1</sup> / <sub>2</sub>									25 <sup>1</sup> / <sub>2</sub>	2625	
				125	WDMT-1004			81 <sup>1</sup> / <sub>2</sub>									31 <sup>1</sup> / <sub>2</sub>	2800	
150	WDMT-1005			37	32	93 <sup>1</sup> / <sub>2</sub>			7 <sup>3</sup> / <sub>8</sub>	3 <sup>1</sup> / <sub>2</sub>	21 <sup>1</sup> / <sub>2</sub>	27	4		37 <sup>1</sup> / <sub>2</sub>	3000			
S	12,000	10	6 @ 1200	10	WDMT-1120	38 <sup>1</sup> / <sub>2</sub>	22	26 <sup>1</sup> / <sub>8</sub>		8 <sup>1</sup> / <sub>8</sub>	4	18 <sup>1</sup> / <sub>4</sub>	25 <sup>7</sup> / <sub>8</sub>	6 <sup>1</sup> / <sub>2</sub>		3	1150	4PS-7/16	
				20	WDMT-1121			34 <sup>7</sup> / <sub>8</sub>									5 <sup>1</sup> / <sub>4</sub>		1200
				30	WDMT-1122			43 <sup>5</sup> / <sub>8</sub>									7 <sup>1</sup> / <sub>4</sub>		1250
				40	WDMT-1122A			53 <sup>5</sup> / <sub>8</sub>									9 <sup>1</sup> / <sub>2</sub>		1250
				60	WDMT-1122B	38 <sup>1</sup> / <sub>2</sub>	22	70 <sup>1</sup> / <sub>8</sub>			8 <sup>1</sup> / <sub>8</sub>	4	18 <sup>1</sup> / <sub>4</sub>	25 <sup>7</sup> / <sub>8</sub>	6 <sup>1</sup> / <sub>2</sub>	4	15 <sup>1</sup> / <sub>2</sub>		1300
T	15,000	20	15 @ 1200	15	WDMT-1150	34	33	42 <sup>1</sup> / <sub>2</sub>		7 <sup>3</sup> / <sub>8</sub>	7 <sup>3</sup> / <sub>8</sub>	22 <sup>1</sup> / <sub>4</sub>	28 <sup>1</sup> / <sub>2</sub>	4	17 <sup>1</sup> / <sub>2</sub>	TVL	2200	2PD-7/16E	
				25	WDMT-1151			51 <sup>1</sup> / <sub>2</sub>							22		2300		
				35	WDMT-1152			57 <sup>1</sup> / <sub>2</sub>								25			2400
				55	WDMT-1152A	34	33	72 <sup>1</sup> / <sub>2</sub>			7 <sup>3</sup> / <sub>8</sub>	7 <sup>3</sup> / <sub>8</sub>	22 <sup>1</sup> / <sub>4</sub>	28 <sup>1</sup> / <sub>2</sub>	4	32 <sup>1</sup> / <sub>2</sub>	TVL		2600
				20	WDMT-1153	38 <sup>1</sup> / <sub>2</sub>	22	34 <sup>7</sup> / <sub>8</sub>	5 <sup>1</sup> / <sub>4</sub>	8 <sup>1</sup> / <sub>8</sub>	4	18 <sup>1</sup> / <sub>4</sub>	25 <sup>7</sup> / <sub>8</sub>	6 <sup>1</sup> / <sub>2</sub>	4	5 <sup>1</sup> / <sub>4</sub>	1200		4PS-7/16E
S	10	10 @ 1200	15	WDMT-1200	37 <sup>1</sup> / <sub>2</sub>	31	59	4 <sup>1</sup> / <sub>2</sub>		8 <sup>1</sup> / <sub>8</sub>	22 <sup>1</sup> / <sub>4</sub>	30 <sup>1</sup> / <sub>2</sub>	6 <sup>1</sup> / <sub>2</sub>	25 <sup>3</sup> / <sub>4</sub>	TVL	2900			
			25	WDMT-1201			74							33 <sup>1</sup> / <sub>4</sub>		3100			
			35	WDMT-1202			90							41 <sup>1</sup> / <sub>4</sub>		3300			
			50	WDMT-1202A			105							48 <sup>3</sup> / <sub>4</sub>		3500			
			15	WDMT-1203			59							25 <sup>3</sup> / <sub>4</sub>		2900			
T	20,000	15	15 @ 1800	25	WDMT-1204			74						33 <sup>1</sup> / <sub>4</sub>		3100	4PD-7/16		
				35	WDMT-1205			90						41 <sup>1</sup> / <sub>4</sub>		3300			
				50	WDMT-1205A	37 <sup>1</sup> / <sub>2</sub>	31	105			8 <sup>1</sup> / <sub>8</sub>	22 <sup>1</sup> / <sub>4</sub>	30 <sup>1</sup> / <sub>2</sub>	6 <sup>1</sup> / <sub>2</sub>	48 <sup>3</sup> / <sub>8</sub>	TVL		3500	
				25	WDMT-1206	44 <sup>1</sup> / <sub>2</sub>	32	46			4	21 <sup>1</sup> / <sub>2</sub>	29 <sup>1</sup> / <sub>2</sub>	6 <sup>1</sup> / <sub>2</sub>	4 <sup>3</sup> / <sub>4</sub>	6 <sup>3</sup> / <sub>4</sub>		2500	
				37	WDMT-1207			59								10		2650	
		16	15 @ 1800	50	WDMT-1208			71								13	2825	4PS-1/2E	
				62	WDMT-1209			83								16	3000		
				75	WDMT-1210	44 <sup>1</sup> / <sub>2</sub>	32	95			4	21 <sup>1</sup> / <sub>2</sub>	29 <sup>1</sup> / <sub>2</sub>	6 <sup>1</sup> / <sub>2</sub>		19	3200		
				15	WDMT-1300	38 <sup>1</sup> / <sub>2</sub>	33	59			8 <sup>1</sup> / <sub>8</sub>	22 <sup>1</sup> / <sub>4</sub>	30 <sup>1</sup> / <sub>2</sub>	6 <sup>1</sup> / <sub>2</sub>	25 <sup>3</sup> / <sub>4</sub>	TVL	2900		
				25	WDMT-1301			74							33 <sup>1</sup> / <sub>4</sub>		3100		
30,000	10	15 @ 1200	35	WDMT-1302	38 <sup>1</sup> / <sub>2</sub>	33	90	4 <sup>1</sup> / <sub>2</sub>	8 <sup>1</sup> / <sub>8</sub>	8 <sup>1</sup> / <sub>8</sub>	22 <sup>1</sup> / <sub>4</sub>	30 <sup>1</sup> / <sub>2</sub>	6 <sup>1</sup> / <sub>2</sub>	41 <sup>1</sup> / <sub>4</sub>	TVL	3300	4PD-7/16E		

### WARNING

The hoisting equipment shown in this bulletin is intended for industrial use only and should not be used to lift, support or otherwise transport human cargo or molten metal.





## FOR IMMEDIATE SERVICE — CALL CHESTER!

Standard Worm Drive Monorail Hoists with motorized trolleys are furnished with 115 VAC pendant-type four button weather-resistant control station with push button drop four feet less than lift. Standard control includes reversing contactors for hoist and trolley, control transformer (115 VAC) and terminal block in a NEMA-12 cabinet, supply voltage 230/460 VAC, 3-phase, 60 Hz and a paddle type limit switch which stops the hook in its upper position.

Standard paint is an air-dried enamel. Standard worm drive hoists are built and tested in accordance with the nationally recognized Safety Standard for overhead hoists ANSI B30.16.

Mounting arrangements available are: Lug, plain trolley, hand geared trolley and motorized trolley. Clearance dimensions shown here for single hook monorail hoist with motorized trolleys are the same for plain and hand geared trolley arrangements. For Lug suspension models subtract (K) dimensions from (A) and (J). All others are the same. If space is critical, ask your Chester Hoist representative or consult factory.

## — HOIST MOUNTINGS —

			
<b>LUG MOUNT SUSPENSION</b> Basic Chester Worm Drive Hoist mounting lets you select the right suspension for your job. Permits use of alternate suspensions with minimum installation problems.	<b>PLAIN TROLLEY SUSPENSION</b> For mounting on I-beam to permit horizontal travel. Useful where loads are not exceedingly heavy for manual movement or where travel speed is not important. Heat-treated ductile iron wheels are mounted on ball bearings for easy movement and long life.	<b>HAND GEARED TROLLEY SUSPENSION</b> Features a closed hand wheel for additional chain guidance and reliable operation. This arrangement is recommended for loads of 3 tons or more — and where accurate spotting is required. Heat-treated ductile iron wheels and ball bearings deliver smooth rolling action.	<b>MOTORIZED TROLLEY SUSPENSION</b> This trolley increases speeds and efficiency of load handling. Worm gearing in all sizes of motorized trolleys assists in smooth acceleration and deceleration. With a motorized trolley suspension, a Chester Worm Drive Hoist can lift and transport loads to 15 tons with push button ease.

## — OPTIONS —

### VERSATILITY

The Chester Worm Drive Hoist design permits adaptation to a wide variety of applications. Variations are available to accommodate special mountings, long lifts, special trolleys, controls, etc. Multiple speeds are available for both hoist and trolley.

### SPECIAL PAINT

The hoist can be provided with any color finish to meet customer requirements. Machine enamel is standard. Epoxy coating is available at extra cost.

### SPECIAL CONTROL ENCLOSURES

Unless otherwise specified, NEMA-12 (Industrial, dust-tight and drip-tight) enclosures will be supplied.

Optional enclosures are available for various non-hazardous locations, as well as certain hazardous locations.

### EXPLOSION-PROOF UNITS

Units are available to meet customer specifications for equipment meeting Class I, Group D or Class II, Groups E, F or G criteria. Spark-resistant features are available when specified (optional, extra cost).

All units are designed in accordance with Chester Hoist's interpretation of the N.E.C. Explosion-proof components such as motor, control enclosure, limit switch, etc, carry the UL Label.

### TWIN HOOK SPACING

Spacing of hooks on Twin Hook models can be provided as required by the application. Suspended units (trolley mounted, monorail) may be specified with hook spacing as great as 15 feet.

### CIRCUITS and CONTROL

All Chester Worm Drive Hoists and motorized trolleys are designed for use on 230/460 volts AC, 3 phase, 60 Hz. Units for operation on 200 VAC, 575 VAC or 50 Hz systems are also available.

IEC contactors are standard. NEMA-rated contactors are available at extra cost.

### ALL TYPES OF LIMIT SWITCHES

Chester Worm Drive Monorail Hoists are furnished with a paddle type upper limit switch. Additional paddle switches, or multi-element geared upper and lower limit switches are also available at extra cost. A geared limit switch is standard on each floor or ceiling mounted unit.

### LOAD-LIMITING SWITCH

A mechanical, positive-acting or an electrical (current-limiting) load limiter is available on Chester Worm Drive Hoist models.

### TROLLEY SPEEDS and BRAKE

Motorized trolleys are available in six different speeds. A trolley motor brake can be supplied at extra cost.

### PUSH BUTTON STATIONS

Some available options include extra push buttons to provide such functions as trolley and crane motion, start-stop control, tandem hoist control and multiple stations.

### INCHING CIRCUIT

An inching circuit allows precise load handling down to a fraction of an inch each time the push button is pressed. This control is often used for accurate spotting of loads (option, extra cost).



# LOW HEADROOM HOISTS 1 to 7 1/2 TONS

Complete with Push Button Transformer Control for operation on 230/460 VAC, 3 phase, 60 Hz



HOIST CAPACITY (LBS.)	TROLLEY FITS SPECIFIC FLANGE WIDTHS (INCHES)
2000 or 3000	3 1/4 to 5
4000 or 6000	3 1/4 to 6
Above 6000	3 1/4 to 7

Chester Low Headroom Worm Drive Hoists are specifically designed for applications requiring minimal hook clearance.

Models are available with lug mount suspension, plain trolley or motorized trolley for efficient lifting and transporting of loads up to 7 1/2 tons.

Because of minimal clearances, Low Headroom Worm Drive Hoists can be operated on straight track only.

Trolleys can be supplied for I-beam, wide-flange or patented track systems. Each trolley is made for a specific beam or track flange width, and is not adjustable to other sizes. Limiting dimensions are shown in the box at left.

## TWIN HOOK MODELS

Twin hook hoists are ideal for moving long, unwieldy loads. Specify desired hook spacing (up to 15 feet on suspended units).



## FLOOR MOUNTED & CEILING MOUNTED WORM DRIVE HOISTS

1/2 to 7 1/2 TONS



For stable lifting of loads from a stationary position such as over a hatchway, loading dock or in an auditorium. Hook spacing available as desired. Spacing up to 40 feet is common.

