

# OPERATION, SERVICE & PARTS MANUAL



***BUDGIT***<sup>®</sup>  
***Hoists***

**MAN & GUARD**<sup>™</sup>  
**electric hoists**

Printed in U.S.A.

**FOREWORD**

This book contains important information to help you install, operate, maintain and service your new Electric Hoist. We recommend that you study its content thoroughly before putting your hoist into use. Then, through proper installation, application of correct operating procedures, and by practicing the recommended maintenance suggestions you will be assured maximum lifting service from the hoist.

Complete inspection, maintenance and overhaul service is available for Budgit Electric Hoists at Authorized Repair Stations. All are staffed by qualified factory-trained service men; have authorized testing equipment; and stock a complete inventory of factory approved Budgit replacement parts.

Complete replacement parts information is given in Section IX. It will likely be a long time before parts information is needed, therefore, after you completely familiarize yourself with operation and preventive maintenance procedures, we suggest that this instruction and parts manual be carefully filed for future reference.

**Notice:** Use only factory approved Budgit replacement parts, available from Authorized Repair Stations or Budgit Hoist Distributors.

The "Accident Prevention Manual for Industrial Operations" (8th Edition) by the National Safety Council states:

"Employees who work near cranes or assist in hooking on or arranging loads should be instructed to keep out from under loads. Supervisors should watch closely to see that this rule is strictly followed.

From a safety standpoint, one factor is paramount: conduct all lifting operations in such a manner that if there were an equipment failure, no personnel would be injured. This means keep out from under raised loads!"

**THE INFORMATION CONTAINED IN THIS MANUAL IS FOR INFORMATIONAL PURPOSES ONLY AND BUDGIT HOISTS DOES NOT WARRANT OR OTHERWISE GUARANTEE (IMPLIEDLY OR EXPRESSLY) ANYTHING OTHER THAN THE COMPONENTS THAT BUDGIT MANUFACTURES AND ASSUMES NO LEGAL RESPONSIBILITY (INCLUDING, BUT NOT LIMITED TO CONSEQUENTIAL DAMAGES) FOR INFORMATION CONTAINED IN THIS MANUAL.**

**INDEX**

| SECTION I                                      | GENERAL DESCRIPTION   | Page         |
|--|---|--------------|
| Paragraph 1-1                                  | General .....   | 3            |
| Paragraph 1-2                                  | Hoist Service Classification .....  | 3            |
| Paragraph 1-3                                  | Basic Construction .....  | 3            |
| Paragraph 1-4                                  | Differences Between Models and Sizes .....                                  | 4            |
| Paragraph 1-5                                  | <b>MAN-GUARD</b> Overload Clutch .....                                      | 4            |
| <b>SECTION II INSTALLATION</b>                 |   |              |
| Paragraph 2-1                                  | General .....   | 4            |
| Paragraph 2-2                                  | Installation .....  | 4            |
| Paragraph 2-3                                  | Pre-Installation Checks .....   | 5            |
| Paragraph 2-4                                  | Connecting Hoist to Electrical Service .....                                | 5            |
| Paragraph 2-5                                  | Electronic Adjustable Limit Switch .....                                    | 5            |
| <b>SECTION III OPERATION</b>                   |   |              |
| Paragraph 3-1                                  | General.....  | 6            |
| Paragraph 3-2                                  | Operating Hoist .....   | 6            |
| Paragraph 3-3                                  | Pulling and Rotating Hoist and Load .....                                   | 6            |
| Paragraph 3-4                                  | Upper and Lower Limit Stops .....   | 6            |
| Paragraph 3-5                                  | <b>MAN-GUARD</b> Overload Clutch Operations .....                           | 7            |
| Paragraph 3-6                                  | Operating Precautions .....   | 7            |
| <b>SECTION IV LUBRICATION</b>                  |   |              |
| Paragraph 4-1                                  | General .....   | 9            |
| Paragraph 4-2                                  | Change Gear Case Oil .....  | 9            |
| Paragraph 4-3                                  | Lubricate Load Chain .....  | 9            |
| Paragraph 4-4                                  | Lubricate Upper Hook and Lower Block Assembly .....                         | 9            |
| Paragraph 4-5                                  | Lubricate Limit Lever Control Shaft and Gears .....                         | 9            |
| <b>SECTION V MAINTENANCE</b>                   |   |              |
| Paragraph 5-1                                  | General .....   | 9            |
| Paragraph 5-2                                  | Thirty-Day Inspection .....   | 9            |
| Paragraph 5-3                                  | Six-Month Inspection .....  | 12           |
| Paragraph 5-4                                  | Inspection 5000 Hour or Five Year .....                                     | 12           |
| <b>SECTION VI TROUBLE SHOOTING CHART .....</b> |   | <b>13-14</b> |
| <b>SECTION VII DISASSEMBLY AND REASSEMBLY</b>  |   |              |
| Paragraph 7-1                                  | General .....   | 14           |
| Paragraph 7-2                                  | Disassembly of Hoist Into Subassemblies .....                               | 15           |
| Paragraph 7-3                                  | Rebuild of Hoist Frame, Sprocket Gear, Sprocket Shaft and Chain Guide ..... | 17           |
| Paragraph 7-4                                  | Rebuild of Load Brake and Overload Clutch Assembly .....                    | 20           |
| Paragraph 7-4a                                 | Overload Clutch without Load Brake .....                                    | 21           |
| Paragraph 7-5                                  | Rebuild of Lower Block and Load Chain Assembly .....                        | 21           |
| Paragraph 7-6                                  | Rebuild of Electrical Controls and Gear Case Cover Subassembly .....        | 23           |
| Paragraph 7-7                                  | Rebuild of Push Button Station and Conductor Cable Assembly .....           | 23           |
| Paragraph 7-8                                  | Rebuild of Contactor Assembly (Push Button Models) .....                    | 24           |
| Paragraph 7-9                                  | Rebuild of Single Phase Motor Assembly .....                                | 24           |
| Paragraph 7-10                                 | Rebuild of Three Phase Motor Assembly .....                                 | 24           |
| Paragraph 7-11                                 | Reassembly of Hoist From Subassemblies .....                                | 24           |
| Paragraph 7-12                                 | Testing Hoist .....   | 31           |
| Paragraph 7-13                                 | Test Procedure For Checking Operation of Overload Clutch .....              | 31           |
| <b>SECTION IX REPLACEMENT PARTS .....</b>      |   | <b>32-36</b> |

**Notice:** Information contained in this book is subject to change without notice.

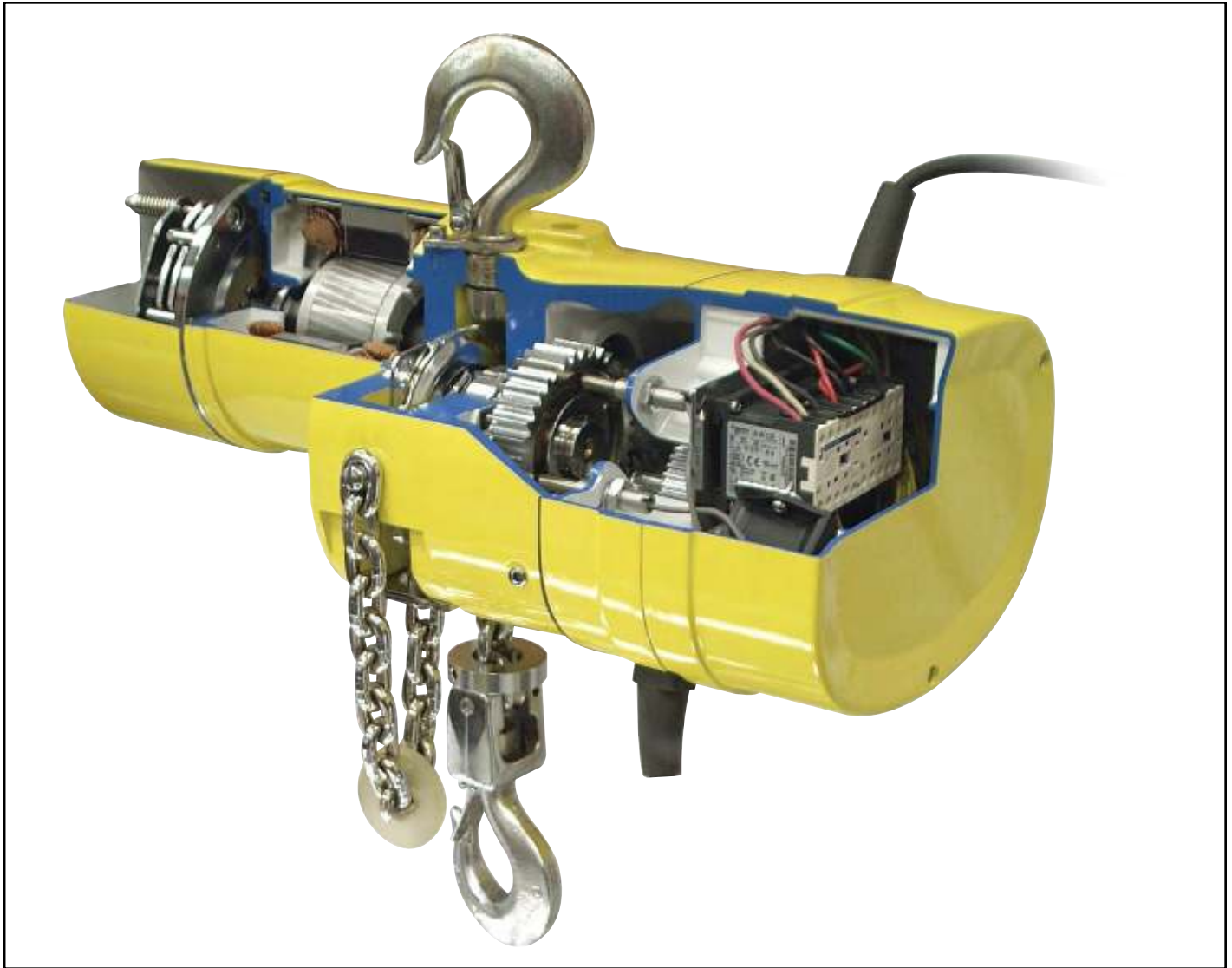

Figure 1-1. Cutaway View Of Typical Budgit Electric Hoist

## SECTION I - GENERAL DESCRIPTION

1-1. GENERAL. **Budgit** Portable Electric Hoists are precision built chain type hoists ranging in six rated load sizes from 1/4 ton through 3 tons with various lifting speeds and electrical power supplies. In addition to the capacities, there are model variations with hook or lug type suspension, and single or two speed. In addition to standard models, there are four rated load sizes of Budgit Electric Hoists ranging from 1/4 ton through 2 tons suitable for plating hoist service with various lifting speeds and electrical power.

### 1-2. HOIST SERVICE CLASSIFICATION

a. **Budgit** electric hoists at the time of manufacture comply with our interpretation of applicable sections of ANSI B30.16 "Overhead Hoists", National Electric Code ANSI/ NFPA 70 and Occupational Safety and Health Act, 1992.

b. OSHA places the burden of compliance for hoist installations on the user. The user must install the equipment in accordance with the National Electric Code ANSI/NFPA 70 as well as other federal, state and local regulations which apply to the installation and application in your particular area.

## **⚠ WARNING**

**Equipment covered herein is not designed or suitable as a power source for lifting or lowering persons. Do not use as an elevator.**

c. These hoists meet ANSI/ASME HST-1M "Performance Standard for Electric Chain Hoists" hoist duty class ratings as outlined in the sales bulletin.

1-3. BASIC CONSTRUCTION. All sizes and models of these **Budgit** Electric Hoists are of the same basic designs, having many common and interchangeable parts. They consist primarily of an aluminum alloy frame and gear case cover which houses the gear train. An electric driving motor and external motor brake are mounted on the rear of the frame, Electrical control components are mounted on front of the gear case cover and encased by aluminum alloy end cover. An upper hook or lug bracket for suspending the hoist is attached to the top of the frame. A high strength low alloy coil load chain with lower block assembly is employed to raise and lower loads. Hoist operation is controlled by a pendant push button station.

1-4. DIFFERENCES BETWEEN MODELS AND SIZES. The main differences between hoist models are in the service classification, type of load chain and the suspension employed. These are described in paragraphs (a) through (c), below. The differences between sizes of hoists are in the number of gear reductions used and the reeving of the load chain. Two-reduction gearing is used for 1/4 through 1/2 ton rated load hoists; three-reduction gearing for 1, 2 and 3 ton rated hoists. On 1/4 through 1 ton rated load hoists, the load chain is single reeved (one part of chain); on 2 ton rated loads, the chain is double reeved (two parts of chain); on three ton rated loads, the chain is triple reeved (three parts of chain).

a. Coil type chain is full-flexing electric welded link chain. It is especially designed for use in **Budgit** Electric Hoists and only factory approved chain of the correct size, pitch, hardness, and strength can be used with these hoists.

b. Suspension differences include a conventional hook type mounting and a lug type mounting. Hook suspension allows portability permitting hoist to be easily moved from job to job. Lug suspension permits hoist to be rigidly mounted to overhead structure or attached to **Budgit** Rigid Mount Trolleys, affording unusual headroom advantage.

c. Some hoists are adaptations of standard model hoists to permit use in some mildly corrosive atmospheres, high ambient temperatures and high duty cycle operation. They are available in either hook or lug suspension. Construction variations from standard models are as follows:

- (1) Load chain is zinc plated for corrosion resistance.
- (2) All exposed aluminum parts are prime painted with corrosion resistant paint.
- (3) Aluminum castings are specially treated.

1-5. **MAN-GUARD OVERLOAD CLUTCH.** **Budgit** Electric Hoists having a **MAN-GUARD** label on the sides of the electrical compartment cover are equipped with an overload clutch that is designed to help guard against excessive overloads. It is a cone-friction clutch that connects the first reduction gear to the clutch pinion shaft. A belleville disc spring provides clutch pressure between the gear and its cone shaped gear center. An excessive overload causes the gear to rotate without turning the gear center and pinion shaft. See paragraph 3-5 for operation.

|  |
|--|
|  <b>WARNING</b>   |
| <p><b>THE MAN-GUARD OVERLOAD CLUTCH IS A PROTECTIVE DEVICE THAT WILL PERMIT OPERATION OF YOUR HOIST WITHIN ITS RATED LOAD AND WILL PREVENT LIFTING OF EXCESSIVE OVERLOADS WHICH CAN CAUSE PERMANENT DEFORMATION OR WEAKENING OF A PROPERLY MAINTAINED HOIST AND/OR ITS SUSPENSION.</b></p> |

**SECTION II - INSTALLATION**

2-1. GENERAL. **Budgit** Electric Hoists are completely lubricated and load tested under their own power before being shipped from the factory. To place hoist in service, attach to suitable overhead suspension (par. 2-2) in area to be used; make pre-installation check (par. 2-3); and connect to the proper power supply (par 2-4).

2-2. INSTALLATION.

|  |
|--|
| <b>NOTICE</b>  |
| Lubricate load chain before operating hoist. See paragraph 4.3 |

a. On hook suspended hoists, select a suitable overhead support in area hoist is to be used (one capable of holding weight of hoist and its rated load) and hang up hoist. Be certain upper hook is firmly seated in center of hook saddle. Upper hook is equipped with a spring type hook latch; it may be necessary to remove latch to attach hook to support. Replace latch after hoist is installed.

b. On lug suspended hoists, select a suitable overhead support in area hoist is to be used (one capable of holding weight of hoist and its rated load). Mount hoist using through bolts, of appropriate size, to fit mounting holes in suspension lug at top of hoist frame. (See table below.) The structure used to suspend hoist must be of sufficient strength to withstand reasonable forces to which hoist and support may be subjected. Hoist must be aligned with load to avoid side pulls.

c. On lug suspended hoists, the suspension lug is factory oriented to cross mount the hoist. This is the recommended orientation. To rotate the lug 90° for parallel mounting, follow instructions below:

(1) On 1/4 through 1 ton hoists, remove the two screws securing the anti-rotation bracket and remove the bracket. Rotate the suspension lug in 90° increments. Reinstall the anti-rotation bracket and secure with two screws and lock washers.

(2) On 2 ton hoists, remove hex socket head screw in lower lock plate. Remove lower lock plate. Rotate suspension lug to selected position and replace lock plate and hex socket head screw.

(3) On 3 ton hoists, the hanger bracket must first be removed from the hoist to provide access to suspension nut per Section VII, par. 7-2. a. (4) and figures 7-2 and 7-3. To remove lug bolt, follow instructions in Section VII, par. 7-3. b. (3). With bolt removed lift lug from hanger and reposition as desired. The lug is located and prevented from turning by integral lugs on adjacent surfaces of the lug and the hanger. Reinstall suspension bolt, spherical washers and nut. Align hole in nut and suspension bolt. Reassemble hanger bracket to hoist.

d. On rigid mount trolley suspended hoists, the trolley side plates must be properly spaced so trolley will fit I-beam on which hoist will operate. Adjustment for various I-beam sizes is accomplished by rearrangement of spacer washers on through bolts which connect trolley side plates to suspension lug on hoist. Refer to instruction sheet furnished with **Budgit** Rigid Mount Trolleys for complete instructions.

**SUSPENSION LUG BOLT SIZES AND SPACING**

| Hoist Rated Load (tons) | Bolt Diameter (in) | Distance Between Holes (in) |
|-------------------------|--------------------|-----------------------------|
| 1/4, 1/2 & 1            | 5/8                | 3-1/8                       |
| 2                       | 1                  | 5                           |
| 3                       | 1-1/4              | 6                           |

2-3. PRE-INSTALLATION CHECK.

**Check Oil Level** (Fig. 4-1). The gear case has been filled with oil, to the proper level at the factory. However, the oil level should be checked before hoist is operated. Remove pipe plug from oil filler on side of hoist frame. Replace with supplied oil hole cover. Check oil level by removing oil level plug (side of frame). Observe if oil level is even with bottom of tapped hole. If it is not, add oil, as specified in paragraph 4-2c. Also check load chain. Be sure it is properly lubricated. See para. 4-3.

**Check Limit Stops:**

**Paddle limit equipped.** Make sure the actuator on the tail chain side is securely pinned to the proper link. (See chart on page 30). On single part hoists, make sure steel actuator is pinned to the first chain link above the lower block. Multiple part reeved hoists do not have an actuator on the lower block side.

**Electronic limit switch equipped.** Make sure the stop on the tail chain side is securely fastened to the proper link. (See chart on page 30). There is no stop on the lower block side.

2-4. CONNECTING HOIST TO ELECTRICAL SERVICE.

a. All hoists are equipped with a flexible power cable extending from the hoist. A grounding type male plug or permanent connection in an outlet box may be used for connecting hoist to power supply. See table (fig. 2-1) for branch circuit conductor sizes.

| H.P.  | Power Supply  | AWG Wire Size |      |      |      |      |     |
|-------|---------------|---------------|------|------|------|------|-----|
|       |               | #16           | #14  | #12  | #10  | #8   | #6  |
| 1/4   | 115-1-60      | 80            | 130  | 210  | 330  |      |     |
|       | 230-1-60      | 230           | 330  | 835  |      |      |     |
|       | 200, 230-3-60 | 465           | 740  | 1180 |      |      |     |
|       | 460, 575-3-60 | 1440          | 2390 |      |      |      |     |
| 1/2   | 115-1-60      | 45            | 75   | 120  | 190  | 310  | 490 |
|       | 230-1-60      | 195           | 305  | 490  | 775  | 1235 |     |
|       | 200, 230-3-60 | 280           | 450  | 715  | 1135 |      |     |
|       | 460, 575-3-60 | 860           | 1440 |      |      |      |     |
| 1     | 115-1-60      | *             | 45   | 75   | 120  | 190  | 300 |
|       | 230-1-60      | 120           | 190  | 300  | 475  | 720  |     |
|       | 200, 230-3-60 | 180           | 290  | 460  | 730  |      |     |
|       | 460, 575-3-60 | 560           | 900  |      |      |      |     |
| 2 1/2 | 200, 230-3-60 | 60            | 100  | 150  | 250  |      |     |
|       | 460, 575-3-60 | 260           | 420  |      |      |      |     |

\*Do not use

Figure 2-1. Branch Circuit Conductor Size. Maximum length in feet for wire size based on horsepower and power supply. Wire size for entire length of branch circuit and permanent wiring to main feeder. Power supply measured at hoist, while running and with normal load, must not vary more than ±5% of voltage on motor nameplate.

b. Follow local & National Electrical Codes when providing electrical service to hoist. Connect power wires in accordance with appropriate wiring diagram. Power supply must be the same voltage, frequency and phase as specified on the hoist nameplate.

**⚠ WARNING**

**The green wire provided in the power supply cable is a grounding wire and must be connected to a proper ground. (Follow local code requirements and/or National Electrical Code Article 250).**

c. Dual voltage hoists with reconnectable 230/460 volts, 3 phase, 60 hertz are (unless otherwise specified on customer's order) shipped from factory pre-connected for operation on 460 volts. If hoist is to be operated on 230 volts convert wiring by changing connections on terminal board. With hoist disconnected from power source, remove electrical compartment cover and reconnect terminal board leads. Refer to Wiring Diagram.

d. Dual voltage hoists with reconnectable 115/230 volts, 1 phase, 60 hertz are (unless otherwise specified on customer's order) shipped from factory pre-connected for operation on 230 volts. If hoists are to be operated on 115 volts convert wiring by changing connections on terminal board. With hoist disconnected from power source, remove electrical compartment cover and reconnect terminal board leads. Also refer to Wiring Diagram.

**⚠ WARNING**

**On electrically operated hoists it is possible to have "Reverse Phasing" causing the lower block to raise when the down button is depressed. When this condition exists, the block operated limit switches will not function properly. Serious damage to the hoist can occur with resulting hazard to operator and load. Hoists must be properly phased each time they are installed or moved to a new power source, or when service is performed on mainline (power source).**

e. To properly phase the hoist follow these steps:

- (1) Temporarily connect hoist to power source.
- (2) Operate "↑" button briefly to determine direction of travel.
- (3) If hook raises, phase is correct and temporary connections should be made permanent.
- (4) **IF HOOK LOWERS, HOIST IS "REVERSE PHASED" AND MUST BE CORRECTED BY INTERCHANGING ANY TWO LEADS AT POWER SOURCE CONNECTION. DO NOT CHANGE INTERNAL WIRING OF HOIST.**

f. For connecting hoist to a motor driven trolley, refer to instructions furnished in trolley manual.

2-5. ELECTRONIC ADJUSTABLE LIMIT SWITCH (if equipped).

The limit switch arrangement consists of two sensors which protrude into the gear case at the sprocket gear, and a control module. The control module has two buttons for programming set points, an UP and DOWN green LED, and a red ALERT LED.

The electronic adjustable limit switch is factory set to the extreme upper and lower limits to allow for testing. The limits may be left as they are, or can be reset according to the following procedure:

When power is first applied to the hoist, one or both of the green LED's should be on, and the red ALERT light should be off. The hoist will operate between the points set at the factory. If red ALERT light is on and both green lights are off, the hoist will not operate, the limits need to be set.

### SECTION III - OPERATION

To set limits:

(1) Press both SET buttons simultaneously. Both green LED's should come on, and the red ALERT LED should flash. Hoist can now be operated through full range of lift.

(2) Raise or lower hook to desired set point. It does not matter whether upper or lower limit is set first. Press the set button that corresponds to UP if the upper limit is to be set first, or DOWN if the lower limit is to be set first. The corresponding green LED should go out.

(3) Move hook to desired upper limit if the lower limit was previously set, or to the lower limit if the upper limit was previously set. The LED corresponding to the limit just set will come back on, indicating the hoist is no longer at that limit. Press the set button that corresponds to UP if the upper limit is being set, or DOWN if the lower limit is being set. The corresponding green LED should go out. The red ALERT light should also go out.

(4) The upper and lower limits are now set. Operate the hoist to confirm the settings are at the desired limits.

Tips for setting limits:

For the initial setting, both limits must be set. If one setting is more critical, that one should be set first. For example, if the position at the lower limit is more important than the position at the upper limit, the lower limit should be set first.

Once the upper and lower limits are set, they can be changed without having to do both *if the new limit is within the previously set limits*. For example, if the lower limit is set too low, stop the hook at the desired position and press the DOWN set button. The hook will now stop at the new limit.

When positioning the hook to set a limit, stop the hook in the same manner as it is likely to be stopped during normal operation. If it is likely that the limit will be reached when the hoist is traveling at full speed, then position the hook by pressing the pushbutton and releasing when the hook is at the desired position, without jogs. If jogs are used to position the hook for setting the limit, the hook may drift past the limit if tripped at full speed.

**Note:** The limit switch has a setting increment of 1/4 revolution of the sprocket gear. This applies when setting the limits. The hoist may stop up to a maximum of 1-1/2 inches before the desired position for 5/16 chain, or 1-1/4 inches for 1/4" chain. Once set, the hoist will repeatedly stop at the same location.

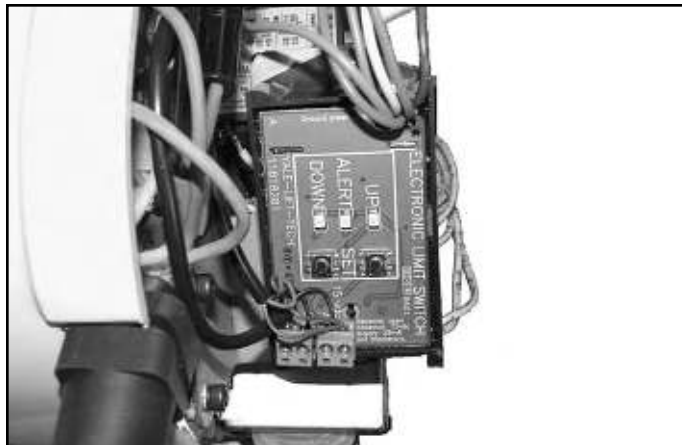

Figure 2-2.

3-1. GENERAL. Operation of **Budgit** Electric Hoists are controlled by a push button station suspended from the hoist electrical compartment. The station has a built-in mechanical interlock to prevent depressing both buttons simultaneously.

3-2. OPERATING HOIST.

- a. Depress push button marked “↑” to raise load.
- b. Depress push button marked “↓” to lower loads.

c. Jogging the push buttons will give “hairline” load movement. The quickness of the depressing motion will determine the amount of movement. Excessive use of this “jogging” feature will cause premature burning of contact points, motor overheating, and rapid motor brake wear.

3-3. PULLING AND ROTATING HOIST AND LOAD.

a. The push button station conductor cable has a built-in strain cable suitable for pulling trolley suspended hoists when not loaded. Do not use for pulling bridge cranes. Push on load or load chain or use a hand geared or motor driven type trolley to traverse loaded hoists.

b. To rotate hoist and load, push on one corner of load. The lower hook will pivot through 360 degrees to permit load to be swung to the desired position. The upper hook (hook suspension models) is also designed to rotate so that side pulls will swing hoist to face load, thus reducing side thrust.

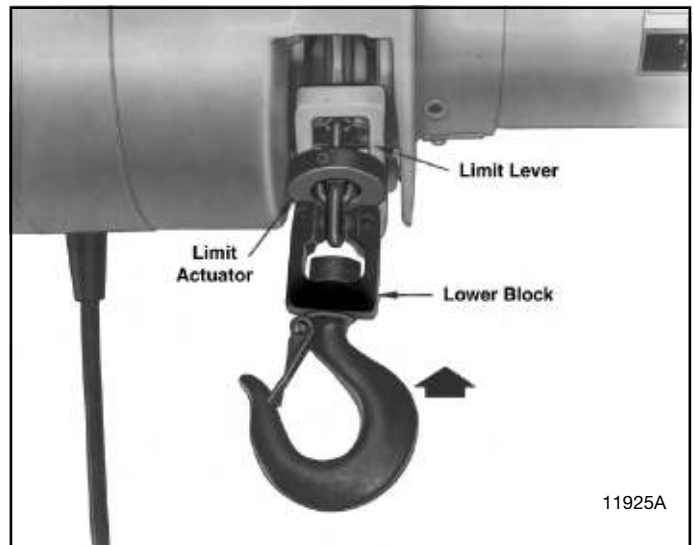

Figure 3-1a. Limit Lever Being Tripped By Actuator Above Lower Block on Single Line Hoist (paddle limit)

3-4 UPPER AND LOWER LIMITS. Budgit Electric Hoists are equipped with either a paddle type limit switch, operated by the lower block in the up direction and an actuator attached to the chain in the lowering direction, or an electronic limit switch which relies on proximity switches mounted in the gear case cover. Refer to the appropriate section below:

3-4a. UPPER AND LOWER LIMIT STOPS (paddle limit). A lower block and chain operated limit stop is provided to guard against overtravel of load in either raising or lowering direction, which can cause damage to hoist. When highest position is reached a limit actuator on the load chain, above the lower block, trips

the limit lever (fig. 3-1a). When lowest position is reached, a limit actuator on the tail end of load chain trips the limit lever (fig. 3-1b). The limit lever is connected to a limit switch that automatically stops the hoist motor. This is intended as a safety device and is not to be used on a routine basis to stop travel of lower block or shut off hoist.

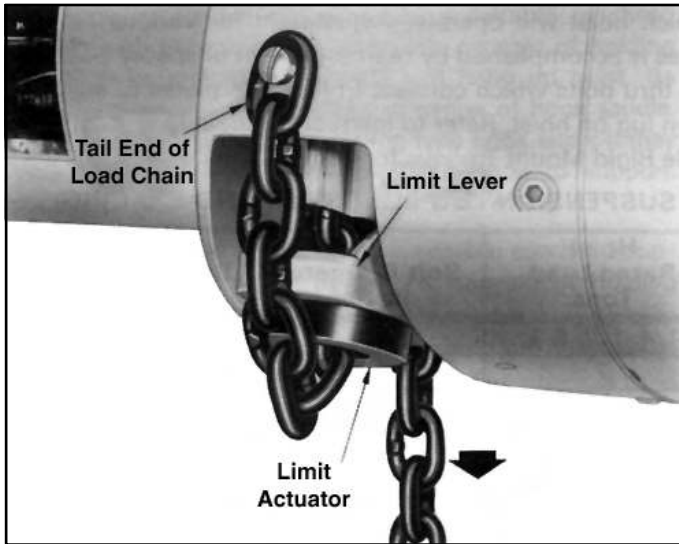

Figure 3-1b. Limit Lever Being Tripped By Actuator on Tail End of a Load Chain (paddle limit)

3-4b. UPPER AND LOWER LIMIT STOPS (electronic limit switch). Upper and lower limit stops are provided to guard against overtravel of load in either raising or lowering direction, which can cause damage to hoist. When highest position is reached, the lower block will cause the overload clutch to slip (fig. 3-1c). When the lowest block position is reached, the tail chain stop will cause the overload clutch to slip (fig. 3-1d). Limit stops are intended as safety devices and are not to be used on a routine basis to stop block travel. Lowering full rated capacity load at full rated speed into the limit stop is an especially severe condition and must be avoided at all times.



Figure 3-1c. Lower Block Contacting Stop Shoe at Upper Limit of Travel (electronic limit switch)



Figure 3-1d. Chain Stop Contacting Stop Shoe Tail Chain End of Load Chain (electronic limit switch)

3-5. OVERLOAD CLUTCH OPERATION. The overload clutch is factory preset at assembly so that the hoist will lift its full rated load but will refuse to lift overloads within a range of 150 percent rated load to 200 percent rated load. If the load to be lifted exceeds the clutch factory setting, the motor will continue to run and will rotate the clutch gear without lifting the load. Whenever this occurs, immediately release the “↑” push button to prevent overheating of the clutch friction surfaces and motor, and reduce the load to rated hoist capacity. Should it be impractical to reduce the load, replace the hoist with one of suitable rated capacity.

**NOTE:** Always know load to be lifted. **Budgit Hoists** does not recommend lifting loads greater than the rated load of your hoist.

3-6. OPERATING PRECAUTIONS.

|  |
|--|
| <p><b>⚠ WARNING</b></p> <p><b>Equipment covered herein is not designed or suitable as a power source for lifting or lowering persons. Do not use as an elevator.</b></p> |
|--|

Safe operation of an overhead hoist is the operator’s responsibility. Following are some basic rules that can make an operator aware of dangerous practices to avoid and precautions to take for his own safety and the safety of others. Observance of these rules in addition to frequent examinations and periodic inspection of the equipment may save injury to personnel and damage to equipment.

- a. **DO read ANSI B30.16 Safety Standard for Overhead Hoists and the Operation, Service and Parts Manual**
- b. **DO be familiar with hoist operating controls, procedures and warnings.**
- c. **DO make sure hook travel is in the same direction as shown on controls.**
- d. **DO make sure hoist limit switches function properly.**
- e. **DO maintain firm footing when operating hoist.**
- f. **DO make sure that load slings or other approved single attachments are properly sized and seated in the hook saddle.**
- g. **DO make sure that the hook latch, is closed and not supporting any part of the load.**
- h. **DO make sure that load is free to move and will clear all obstructions.**
- i. **DO take up slack carefully, check load balance, lift a few inches and check load holding action before continuing.**
- j. **DO avoid swinging of load or load hook.**
- k. **DO make sure that all persons stay clear of the suspended load.**
- l. **DO warn personnel of an approaching load.**
- m. **DO protect load chain from weld splatter or other damaging contaminants.**
- n. **DO promptly report any malfunction, unusual performance, or damage of the hoist.**
- o. **DO inspect hoist regularly, replace damaged or worn parts, and keep appropriate records of maintenance.**
- p. **DO use the hoist manufacturer's recommended parts when repairing a hoist.**
- q. **DO use hook latches wherever possible.**
- r. **DO apply lubricant to load chain as recommended. DO NOT lift more than rated load.**
- s. **DO NOT use the hoist load limiting device to measure the load.**
- t. **DO NOT use damaged hoist or hoist that is not working correctly.**
- u. **DO NOT use the hoist with twisted, kinked, damaged or worn chain.**
- v. **DO NOT lift a load unless chain is properly seated in chain wheel(s) or sprocket(s).**
- w. **DO NOT use load chain as a sling or wrap chain around the load.**
- x. **DO NOT lift a load if any binding prevents equal loading on all supporting chains.**
- y. **DO NOT apply the load to the tip of the hook.**
- z. **DO NOT operate unless load is centered under hoist.**
- aa. **DO NOT allow your attention to be diverted from operating the hoist.**
- ab. **DO NOT operate the hoist beyond limits of load chain travel.**
- ac. **DO NOT use limit switches as routine operating stops. They are emergency devices only.**
- ad. **DO NOT use hoist to lift, support or transport people.**
- ae. **DO NOT lift loads over people.**
- af. **DO NOT leave a suspended load unattended unless specific precautions have been taken.**
- ag. **DO NOT allow sharp contact between two hoists or between hoist and obstructions.**
- ah. **DO NOT allow the chain or hook to be used as a ground for welding.**
- ai. **DO NOT allow the chain or hook to be touched by a live welding electrode.**
- aj. **DO NOT remove or obscure the warnings on the hoist.**
- ak. **DO NOT adjust or repair a hoist unless qualified to perform hoist maintenance.**
- al. **DO NOT attempt to lengthen the load chain or repair damaged load chain.**
- am. **DO NOT allow personnel not physically fit or properly qualified to operate the hoist.**
- an. **DO NOT operate hoist unless upper and lower limit switch stops are operating properly.**
- ao. **DO always be sure there is no twist in coil load chain. On 2 & 3 ton coil chain hoists, check to see that lower block is not capsized between strands of chain.**
- ap. **DO avoid operating hoist when hook is not centered under hoist. Be sure that hoist trolley or other support mechanism is correctly positioned for handling the load before lifting.**
- aq. **DO operate hoist within recommended duty cycle and do not "jog" unnecessarily.**
- ar. **DO conduct regular visual inspections for signs of damage or wear.**
- as. **DO NOT operate hoist with hooks that have opened up. See Figures 5-5 and 5-6.**
- at. **DO provide supporting structure or anchoring means that has a load rating at least equal to that of the hoist.**
- au. **DO NOT use hoists in locations that will not allow operator movement to be free of the load.**
- av. **DO when starting to lift or pull, move the load a few inches at which time the hoist should be checked for proper load holding action. The operation shall be continued only after the operator is assured that the hoist is operating properly.**
- aw. **DO NOT leave a loaded hoist unattended at the end of a work shift or for extended periods during the work shift. Where operations are such that this condition cannot be avoided the operator must be assured that the condition does not create a hazard to personnel or property.**
- ax. **DO use common sense and best judgement whenever operating a hoist. Observe American National Standard Safety standard, ANSI B30.16, latest issue.**



**SECTION IV - LUBRICATION**

4-1. GENERAL. The lubrication services outlined in paragraphs 4-2 through 4-5 should be performed at regular intervals to maintain top hoist performance and insure long life. The frequency for lubrication services will depend on the type of hoisting service that hoist is subjected to and should coincide with periodic preventive maintenance inspection. See Section V-Maintenance.

4-2. CHANGE GEAR CASE OIL (Fig. 4-1).

- a. Remove drain plug from bottom of hoist frame and drain oil from gear case. Replace plug.
- b. Remove oil level plug from side of hoist.
- c. Refill gearcase through oil filler to proper level (bottom of oil level plug hole) using Automatic Transmission Fluid - DEXRON Type. This is an all-weather oil available from all major oil companies. 1-1/2 pints of oil are required.
- d. Reinstall oil level plug and breather.

4-3. LUBRICATE LOAD CHAIN. A small amount of lubricant will greatly increase load chain life, therefore, chain should not be allowed to run without lubricant. Chain should be cleaned and lubricated as directed in paragraph a below. User should set up a regular schedule for chain lubrication after observing operating conditions for a few days. Use Bar and Chain Oil (LUBRIPLATE or equal) on load chain.

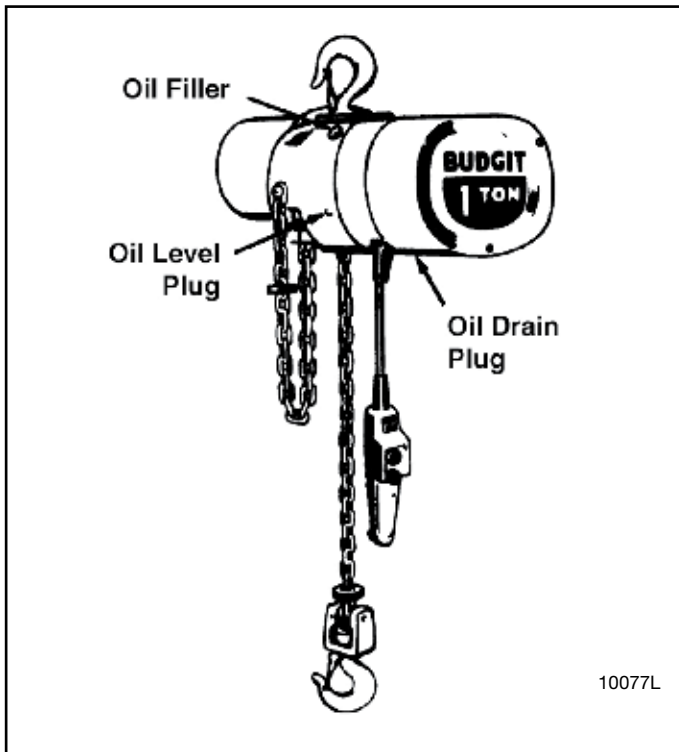

Figure 4-1. Location of Oil Filler and Plugs

a. Coil Chain. Under ordinary conditions only weekly attention will be necessary. Under hot and dirty conditions it may be necessary to clean chain at least once a day and lubricate it several times between cleanings. Thoroughly clean chain with an oil solvent and re-lubricate by coating it lightly with oil. Make sure that lubricant coats wear surfaces between links. Zinc plated load chain should be cleaned and lubricated daily.

4-4. LUBRICATE UPPER HOOK AND LOWER BLOCK ASSEMBLY.

- a. Apply a few drops of Bar and Chain Oil on shank of upper hook where it enters frame.
- b. Apply a few drops of Bar and Chain Oil on shank of lower hook where it enters lower block. Hook rotation bearing may be removed for cleaning and re-lubricating if necessary. See section 7-5.
- c. On lower block assemblies of 2 and 3 ton capacity hoists, also apply heavy duty lithium soap grease with EP additives through pressure fitting in end of sprocket pin to lubricate bearing in chain sprocket.
- d. On 3 ton model lubricate sprocket in hanger bracket with a few drops of Bar and Chain Oil in hole provided in center of sprocket hub.

4-5. LUBRICATE LIMIT LEVER CONTROL SHAFT AND GEARS.

Apply a few drops of Bar and Chain Oil on limit lever shaft at bearing points.

|  |
|--|
| <p><b>▲ WARNING</b></p> <p><b>Before performing any internal work on hoist, be certain power is shut off. Lock main service switch in the open position.</b></p> |
|--|

**SECTION V - MAINTENANCE**

5-1. GENERAL. Preventive maintenance services required on **Budget** Electric Hoists are for the most part, simple periodic inspection procedures to determine condition of hoist components. Below are suggested inspection procedures, based on daily average hoist usage.

5-2. THIRTY-DAY INSPECTION. Hoist may be left suspended.

a. Inspect Load Chain.

(1) Operate hoist under load and observe operation of chain over sprocket in both directions of chain travel. Chain should feed smoothly into and away from the sprocket. If chain binds, jumps or is noisy, first see that it is clean and properly lubricated. If trouble persists, inspect chain as outlined below.

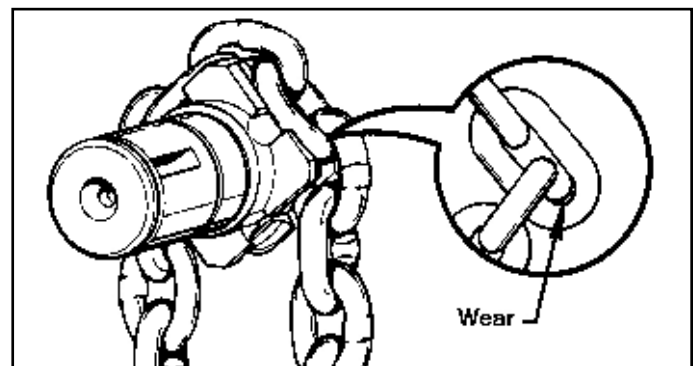

Figure 5-1. Check Chain Wear at Bearing Surfaces Between Links

(2) **Coil Type Load Chain.** Clean chain for inspection. Examine visually for gouges, nicks, weld spatter, corrosion or distorted links. Slacken chain and check bearing surfaces between links

for wear, fig. 5-1. Greatest wear will often occur at sprocket at high or low point of lift, particularly when hoist is subjected to repetitive lifting cycles. Case hardness of chain is about 015" deep. Chain must be replaced before the case is worn through. Also check chain for elongation using a vernier caliper (fig. 5-2). Select an unworn, unstretched section of chain (usually at slack or tail end) and measure and record the length over the number of chain links (pitches) indicated in figure 5-2. Measure and record the same length of a worn section in the load side of the chain. Obtain the amount of wear by subtracting the measurement of the unworn section from the measurement of the worn section. If the result (amount of wear) is greater than the amount specified in the "ALLOWABLE CHAIN WEAR" table, the chain has elongated beyond the maximum allowable length and must be replaced. Chain with excessively pitted, corroded, nicked, gouged, twisted or worn links should be replaced using only factory approved chain. Never weld or attempt to repair coil chain.

hoist frame and removing limit actuator. New chain is then run into hoist as old chain is run out. Use open "C" links, figures 5-3 and 5-4, for attaching chains. Links must be identical in size to hoist chain - 1/4" wire size with .745" pitch length for 1/4 through 1/2 ton models, 5/16" wire size with .858" pitch for 1 through 3 ton models. Be certain that all welds on links of replacement chain face away from center of load sprocket.

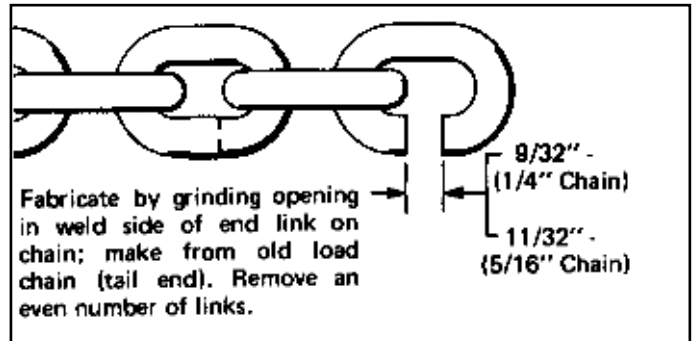

Figure 5-3. Open "C" Link for Removing and Installing Coil Load Chain

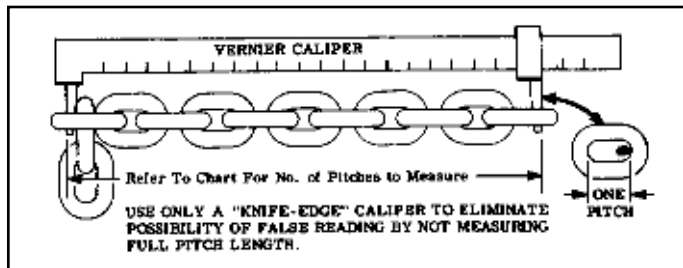

Figure 5-2. Check Coil Chain Using Vernier Caliper

**ALLOWABLE CHAIN WEAR - ELONGATION**

| Hoist Rated Load (tons) | Chain Size (wire dia.) | No. of Pitches to Measure | Maximum Wear Limit |
|-------------------------|------------------------|---------------------------|--------------------|
| 1/4 & 1/2               | 1/4"                   | 13                        | .145"              |
| 1 thru 3                | 5/16"                  | 11                        | .142"              |



Figure 5-4. Installing Coil Load Chain Using Two "C" Links (1/4, 1/2 & 1 ton hoists)

(b) Remove lower block assembly and actuator from old chain and attach them to replacement chain at end which was just run through hoist. Install limit actuator (as noted below) on other end of chain and anchor chain to side of hoist frame.

**⚠ WARNING**

Do not assume that load chain is safe because it measures below replacement points given herein. Other factors, such as those mentioned in visual checks above, may render chain unsafe or ready for replacement long before elongation replacement is necessary.

**⚠ WARNING**

To avoid serious personal injury from a dropped load caused by chain breakage, when replacing coil load chain, use only factory approved chain conforming to Budgit hoist specifications for material, hardness, strength and link dimensions. Chain not conforming to factory Specifications may be dangerous as it will not fit in the load sprocket and chain guide correctly, causing serious internal damage to hoist and it will wear prematurely, deform and eventually break.

**NOTICE**

Use one or two "C" links to orient chain for chain anchor screw. Position first link of new chain to be flat against hoist housing without twisting the chain.

**NOTE:** See table on page 30 for location of tail chain limit stop.

On 2 ton double reeved models, also connect opposite end of chain (from lower block) to load chain anchor inside of frame. On 3 ton triple reeved models, the opposite end of the chain is attached to the lower block connecting link.

(3) Removing and Replacing Coil Load Chain.

(a) Replacement Coil load chain is installed by attaching it to tail end of old chain, after disconnecting old chain from side of

**NOTE:** In the event the old chain is to be removed from hoist and reinstalled, a short length of chain (about 18" long) must be run into hoist when the old chain is removed. This short length can then be used in the same manner as shown in paragraph 5-2. a.(3). Be sure to use the proper number of open "C" links in order to correctly position end link on tail end of chain to fit anchor at side of hoist frame.

**NOTICE**

To avoid serious internal damage to hoist, when installing coil load chain do not attempt to hand feed chain into hoist, or use a piece of wire in place of the method described herein. To do so may result in serious internal damage to hoist, as coil chain links must be properly seated in chain sprocket before chain is run into hoist. Install chain only as described in this manual.

**CAUTION**

Keep fingers clear of chain sprocket when replacing load chain.

(4) Check connection of chain to lower block on 1/4 through 1 and 3 ton hoists. Replace parts showing evidence of damage, twisting or elongation.

(5) Check connection of chain to anchor inside hoist frame on double-reeved, 2-ton hoists. Replace parts showing evidence of damage, twisting or elongation. (Also see Sec. VII, par. 7-2. a. (2)).

(6) Lubricate load chain before using hoist. See paragraph 4-3, Section IV.

**b. Inspect Lower Block.**

(1) Check for bent or distorted hook. If hook is opened beyond the dimension given in figure 5-5, it must be replaced. Also check to see that hook swivels and is free to pivot. Lubricate these points if necessary.

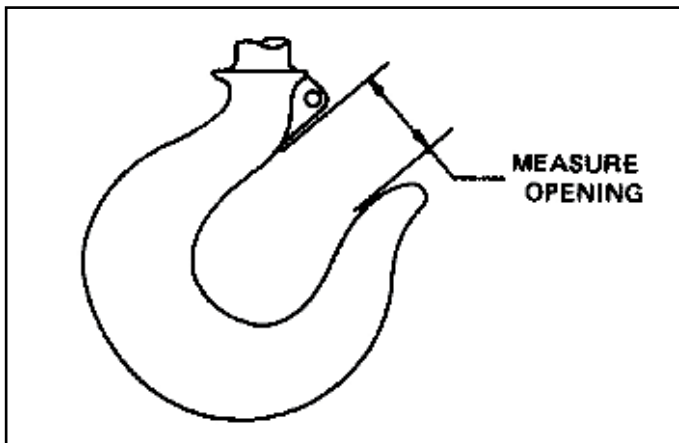

Figure 5-5. Lower Hook Opening (Shown with latch removed for clarity.)

| Hoist Rated Load (tons) | Hook Throat Opening |   |
|-------------------------|---------------------|---|
|                         | Normal Opening      | Replace Hook if Opening is Greater Than |
| 1/4 & 1/2               | 1-1/8               | 1-1/4                                   |
| 1                       | 1-1/4               | 1-7/16                                  |
| 2                       | 1-3/8               | 1-9/16                                  |
| 3                       | 1-1/2               | 1-11/16                                 |

(2) On 2 through 3 ton hoists, check sprockets and bearings in lower block for freedom of movement and signs of damage. Lubricate if necessary. Replace damaged parts.

(3) Check hook latches. Replace damaged or bent latches or broken springs.

**WARNING**

Hooks, upper or lower, damaged from chemicals, deformation or cracks or having more than 15 percent in excess of normal throat opening or more that 10 degrees twist from the plane of the unbent hook, or opened, allowing the hook latch to bypass hook tip must be replaced. Any hook that is twisted or has excessive throat opening indicates abuse or overloading of the hoist. Other load bearing components of the hoist should be inspected for damage. (See Section V. Par. 5-2. d. (2) below).

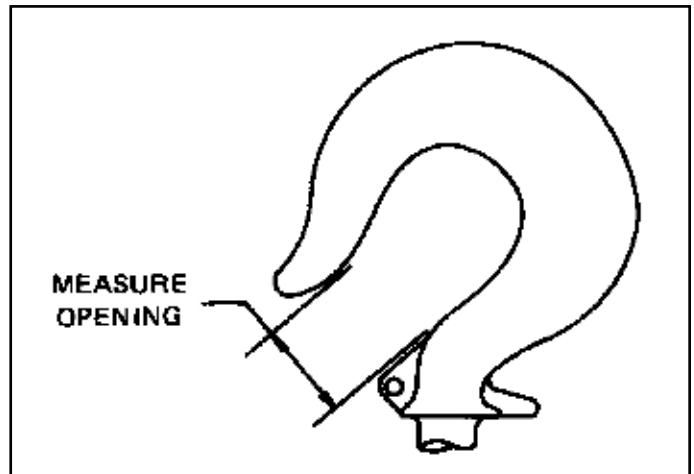

| Hoist Rated Load (tons) | Hook Throat Opening |   |
|-------------------------|---------------------|---|
|                         | Normal Opening      | Replace Hook if Opening is Greater Than |
| 1/4 & 1/2               | 1-1/8               | 1-1/4                                   |
| 1                       | 1-1/4               | 1-7/16                                  |
| 2                       | 1-3/8               | 1-9/16                                  |
| 3                       | 1-1/2               | 1-11/16                                 |

Figure 5-6. Upper Hook Opening (Shown with latch removed for clarity.)

**c. Inspect Upper Suspension.**

(1) On hook suspended models, check for bent or distorted hook. If hook is opened beyond the dimension given in figure 5-6, it must be replaced. Also check to see that hook pivots. Lubricate if necessary.

(2) On lug suspended models, check condition of suspension lug. Replace lug if damaged or cracked. Check to see that lock plate is in place on lug and screw holding it is tight. (All capacities see figure 7-20).

(3) On 2-ton hoists, check to see that upper lock plate securing hook or lug bushing is in place and screws holding it are tight. Lubricate hook shank.

(4) Check hook latch. Replace damaged or broken parts.

(5) Inspect threaded upper suspension bushing. Verify keeper is in place against flat of suspension bushing, and securing screw and lock washer are in place and tight.

**d. Inspect Motor, Frame and Electrical Compartment Cover.**

(1) Check to see that bolts securing motor to frame are tight. Also check for any visible damage to motor, such as a cracked end bell or dented stator housing. Replace damaged parts.

(2) Check hoist frame for signs of visible damage. If frame shows evidence of fracture, the hoist should be disassembled and inspected for further signs of damage from possible overloading. Replace damaged parts.

(3) Check for possible damage to electrical compartment cover. Be sure screws holding cover are tight.

**e. Check Oil Level.** Remove oil level plug (fig. 4-1). If oil level is not even with bottom of tapped hole, add Automatic Transmission Fluid, DEXRON Type, to bring to proper level.

5-3. SIX-MONTH INSPECTION OR 500-750 HOURS OF OPERATION. Hoist may be left suspended. Same as thirty day inspection plus the following:

**a. Inspect Electrical Controls.** Shut off power supply to hoist and remove electrical compartment cover from hoist. Use caution as some covers contain counterweights. Two speed hoists with a 2-1/4 horsepower motor have an externally mounted counterweight at the electrical compartment cover.

(1) Check all wiring and terminals. Insulation should be sound and terminals securely crimped to wires. Terminal screws should be tight and plug-type terminals completely mated. Replace terminals or wires as necessary.

(2) Check control circuit transformer for evidence of overheating. Replace if necessary.

(3) Check limit switch to see that wires are securely attached and mounting screws are tight.

(4) Check contactor solenoid coils and replace coils if they show evidence of overheating.

(5) Check control cable wire strain reliever to see that it is in good condition and securely attached to gear case cover. Replace rubber strain reliever grommets if damaged.

**a. Change Gear Case Oil.** See Section IV, paragraph 4-2.

**b. Relubricate Load Chain.** See Section IV, paragraph 4-3.

**c. Lubricate Upper Hook and Lower Block.** See Section IV, paragraph 4-4.

5-4. INSPECTION: 5000 HOURS "ON" TIME OR 5 YEARS ELAPSED TIME. Hoist must be removed from overhead suspension.

**a. Disassemble Hoist into Subassemblies.** Follow procedure outlined in Section VII, paragraph 7-2.

**b.** Motor shaft oil seal, sprocket shaft bearing, seal and all gaskets should be replaced.

**c. Inspect Load Brake and Overload Clutch.** Disassemble load brake (if equipped) and clutch assembly as outlined in paragraph 7-4. Friction discs should be discarded and replaced with new discs. Check load brake friction surfaces on flange, ratchet assembly and gear clutch cone. Replace parts if badly scored or worn. Check condition of pawl and ratchet assembly. If pawl, ratchet teeth or pawl spring are broken, damaged or badly worn, replace complete assembly. Check contact faces of load brake cam and gear clutch cone. Brake gear and pinion teeth should be inspected for wear or broken teeth. Clean parts thoroughly with an oil solvent before reassembly.

**NOTE:** The overload clutch assembly should not be disassembled as it is preset at the factory to provide proper clutch pressure for a specific hoist capacity range. If there is evidence of the clutch slipping or wear or damage to the clutch components, the complete clutch assembly should be replaced or sent to an authorized Budget Hoist Repair Station to be rebuilt and properly adjusted to factory specifications.

**d. Inspect Sprocket and Intermediate Gears.**

(1) On 1 through 3 ton hoists, check condition of gear teeth on intermediate gear and pinion shaft assembly. Replace worn or damaged parts.

(2) Check condition of pockets on chain sprocket (all capacities). Replace worn or damaged parts.

**e. Inspect Motor Brake.** Check braking surfaces for wear and scoring. Replace badly worn or scored parts. Check spring studs and guide pins to make sure they are not bent or loose. Check coil shock mounts for deterioration and damage. Check air gap adjustment. (See 7-11c)

**f. Reassemble and Test Hoist.** Reassemble hoist from subassemblies following procedure outlined in paragraph 7-11. After assembly is complete, test hoist as outlined in paragraphs 7-12 and 7-13.

**SECTION VI - TROUBLE SHOOTING**

| <b>Trouble</b>   | <b>Probable Cause</b>  | <b>Remedy</b>  |
|--|--|--|
| 6-1. Hoist Will Not Operate.                                 | <p>a. No power to hoist.</p> <p>b. Wrong voltage.</p> <p>c. No control voltage.</p> <p>d. Loose or broken wire connections in hoist electrical system.</p> <p>e. Contactor assembly not functioning.</p> <p>f. Starting switch burned out (single phase motor).</p> <p>g. Motor burned out.</p> <p>h. Electronic Limit Switch not set.</p> | <p>a. Check switches, circuit breakers and connections in power supply lines. Check power collectors.</p> <p>b. Check voltage required on motor data plate against power supply.</p> <p>c. Check transformer fuse. If blown, check for grounding and/or short in the pushbutton station. Check the transformer coil for signs of overheating. Replace transformer if burned out. Verify the transformer secondary is the same voltage as the coils to which it is connected.</p> <p>d. Shut off power supply, remove electrical cover from hoist and check wiring connections. Also check connections in push button station and limit switches.</p> <p>e. Check for burned out solenoid coil. See that the necessary jumper wires are properly installed.</p> <p>f. Replace burned out parts.</p> <p>g. Replace motor. On single-phase motors the starting switch may be burned out.</p> <p>h. Adjust electronic Limit Switch. See section 2-5.</p> |
| 6-2. Hook Moves in Wrong Direction.                          | <p>a. Reverse phasing on three-phase hoists.</p> <p>b. Hoist wired wrong.</p> <p>c. Starting switch not working correctly (single phase motor).</p>  | <p>a. Interchange any two of the three power supply line leads. Do not change green ground lead. Refer to Section II, par. 2-4.</p> <p>b. Check wiring connections with appropriate wiring diagram.</p> <p>c. Check for correct starting switch part number and function. Replace if necessary.</p>  |
| 6-3. Hook Will Raise But Not Lower.                          | <p>a. "DOWN" electrical circuit open.</p> <p>b. Contactor assembly not functioning.</p> <p>c. Push Button Inoperative.</p> <p>d. Load Brake locked up and overload clutch slipping.</p>  | <p>a. Check for loose connections. See that necessary jumper wires are properly installed on contactor. Check limit switch condition and electrical connections.</p> <p>b. See that necessary jumper wires are properly installed. Verify that the contactor armatures are free to move. If binding occurs replace contactor. Check for burned out contactor coils.</p> <p>c. Check push button contacts and wires.</p> <p>d. Consult Authorized <b>Budgit</b> Hoist Repair Station.</p>   |
| 6-4. Hook Will Lower But Not Raise (continued on next page). | <p>a. Excessive load, causing overload clutch to slip.</p> <p>b. Overload clutch out of adjustment.</p> <p>c. "UP" electrical circuit open.</p>  | <p>a. Reduce loading to rated load of hoist, as shown on nameplate.</p> <p>b. Test hoist and replace clutch if hoist will not lift rated load.</p> <p>c. Check for loose connections. See that necessary jumper wires are properly installed on contactor. Check limit switch condition and electrical connections.</p>  |

**SECTION VI - TROUBLE SHOOTING (Continued)**

| Trouble   | Probable Cause   | Remedy  |
|---|--|---|
| 6-4. Hook Will Lower But Not Raise (continued). | d. Contactor assembly not functioning.<br><br>e. Push button inoperative.  | d. See that necessary jumper wires are properly installed. Verify that the contactor armatures are free to move. If binding occurs replace contactor. Check for burned out contactor coils.<br><br>e. Check push button contacts and wires.   |
| 6-5. Hoist Will Not Lift Rated Load.            | a. Low voltage<br><br>b. Overload clutch out of adjustment.<br><br>c. Motor brake not releasing.   | a. See that power supply is same voltage listed on motor data plate. Check size of power supply lines. Refer to fig. 2-1.<br><br>b. Remove and replace clutch assembly. Refer to Section IV, par. 7-2 and 7-4.<br><br>c. Check brake components. Refer to Section VII, par 7-2.d, 7-2.e.  |
| 6-6. Excessive Drift When Stopping.             | a. Excessive load.<br><br>b. Motor brake not holding.<br><br>c. Motor brake not setting due to insufficient plunger air gap.<br><br>d. Load brake not holding.   | a. Reduce loading to rated load, shown on nameplate.<br><br>b. Check brake components. Refer to Section VII, par. 7-2.d.<br><br>c. Adjust air gap. Refer to Section VII, par. 7-11.c.<br><br>d. Remove load brake and inspect parts. Refer to Section V, par. 5-4.  |
| 6-7. Hoist motor overheats.                     | a. Excessive load.<br><br>b. Excessive duty-cycle.<br><br>c. Excessive "jogging."<br><br>d. Wrong voltage.<br><br>e. Starting switch on single-phase motors not opening starting winding.<br><br>f. Damaged motor or worn bearings in motor or hoist frame.<br><br>g. Motor brake not releasing. | a. Reduce loading to rated load of hoist, shown on nameplate<br><br>b. Reduce frequency of lift.<br><br>c. Reduce frequency of jogs.<br><br>d. Check voltage rating on motor data plate against power supply.<br><br>e. Refer to Section VII, par. 7-9.b. (3) (b). Inspect Switch.<br><br>f. Disassemble hoist and inspect for worn or damaged parts.<br><br>g. Check brake components. Refer to Section VII, par. 7-2.d. |

**SECTION VII - DISASSEMBLY AND REASSEMBLY**

7-1. GENERAL.

a. The following disassembly and reassembly instructions apply to all standard models in the line of **Budgit** Electric Hoists equipped with **MAN-GUARD** overload clutch. Where needed, variations to instructions are provided to cover differences between models (suspensions, rated load sizes and motor voltage ratings), with applicable models specifically noted.

b. A complete teardown procedure is given, however, if only certain parts require repair or replacement, a partial teardown may be performed using the applicable portions of the instructions.

c. For easier handling during disassembly, the following disassembly steps may, where conditions permit, be completed

before hoist is removed from its overhead suspension or disconnected from its power supply: Remove chain container, if hoist is so equipped; remove lower block and load chain assembly, following procedure outlined in paragraph 7-2. a. Drain and discard gear case oil, by removing plug at bottom of frame.

d. These hoists contain precision machined parts and should be handled with care at disassembly and at reassembly. When removing or installing parts with press fits, be careful to apply pressure evenly. On ball bearings, apply pressure to face of inner or outer race, whichever is adjacent to mating part. This will avoid damage to bearing races from brinelling by pressing through bearing balls. Apply a thin film of sealant to parts having a press fit when they are installed.

7-2. DISASSEMBLY OF HOIST INTO SUBASSEMBLIES.

### a. Removal of Lower Block and Load Chain Subassembly.

(1) On models with single-reeved load chains (1/4 through 1 ton rated loads) disconnect tail end of load chain from anchor at side of frame. Remove fillister head screw holding end link to frame. Remove grooved pin from the limit actuator and pull it off end of chain. With hoist connected to power supply, run chain out of hoist by operating in “lowering” direction. (See note following paragraph (2) below and note in Sec. V, par. 5-2. a. (3) for inserting short length of chain.)

(2) On models with double-reeved load chains (2 ton hoists) disconnect tail end of load chain from anchor at side of hoist frame and remove limit actuator as in (1) above, run chain out of hoist by operating it in “lowering” direction, and disconnect opposite end of load chain from anchor inside hoist frame. To disconnect this end of chain, remove cotter pin from end of anchor pin, press pin from anchor and withdraw chain. The drive pin securing threaded end of anchor in upper block assembly (at top of frame) must be removed in order to rotate the anchor.

**NOTE:** If hoist is inoperative and **not** equipped with a load brake, chain can be pulled through by hand by first manually releasing motor brake. If hoist is equipped with a load brake it will be necessary to wait until after load brake is removed (paragraph. c., below), then the chain can be pulled through the hoist by hand.

(3) On triple-reeved 3 ton hoists, remove retaining ring and connecting link pin as shown in figures 7-30 and 7-31. Remove connecting link with chain from lower block.

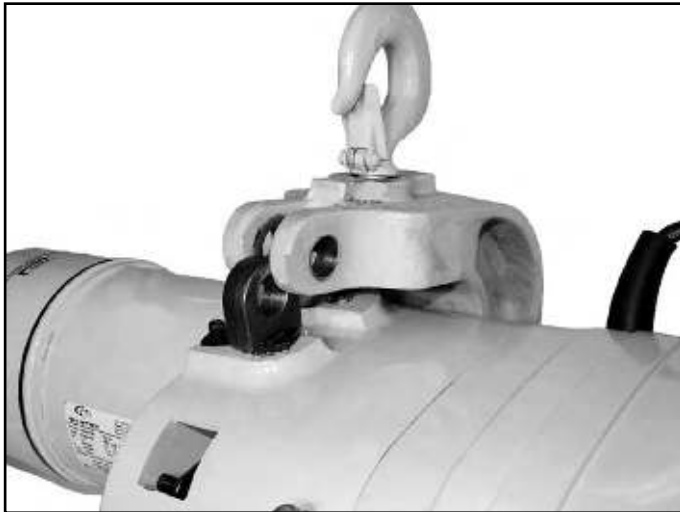

Figure 7-2. 3 Ton Hanger Bracket Connection Pin Removed

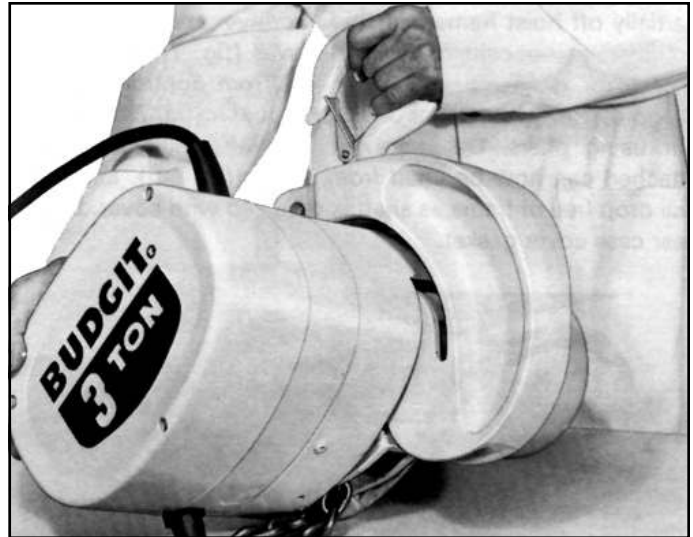

Figure 7-3. Removing 3 Ton Hanger Bracket from Hoist Frame

To remove connecting link from chain, take out cotter key and push anchor pin from connecting link. Chain can now be pulled through hanger bracket and lower block. Unfasten tail chain from hoist frame, remove limit actuator, and if power is available, operate hoist in lowering direction to remove chain. (See note in Sec. V, par. 5-2. a. (3) for inserting short length of chain). If hoist is inoperative see note below but be sure to install short length of chain into hoist before removing load chain.

**NOTE:** If hoist is inoperative and **not** equipped with a load brake, chain can be pulled through by hand by first manually releasing motor brake. If hoist is equipped with a load brake it will be necessary to remove load brake (paragraph. c., below) so chain can be pulled through the hoist by hand.

(4) To remove 3 ton hanger bracket from hoist, remove retaining ring and connecting rod pin (see fig. 7-2). Rotate hoist approximately 45° (see fig. 7-3) and hanger will slip free from hoist frame.

### b. Removal of Electrical Compartment Cover, Electrical Controls and Gear Case Subassembly.

(1) Disconnect hoist from power source. Remove three cover retaining screws and lift off cover (fig. 9-1). Cover screws have retaining rings which hold them in cover. Use caution as some covers contain counterweights. Two speed hoists with a 2-1/4 horsepower motor have an externally mounted counterweight at the electrical compartment cover.

(2) Disconnect push button conductor cable leads at plug-in type connectors that can be pulled apart. Remove screw and washer securing strain reliever (fig. 9-8) and pull the cable and grommet from its slot in gear case cover.

(3) Disconnect power supply flexible cable leads from terminals of contactor. Remove screw attaching ground leads to gear case cover and pull flexible cable and grommet from slot in cover.

(4) Disconnect motor leads from electrical control units. Number of leads depends on type of motor. (See wiring diagrams in accompanying this manual).

(5) Remove eight hex socket head screws and lockwashers securing gear case cover to hoist frame. Pry gear case cover off hoist frame using screw driver at special notches provided at opposite corners of cover (fig. 7-4). Discard gear case cover gasket.

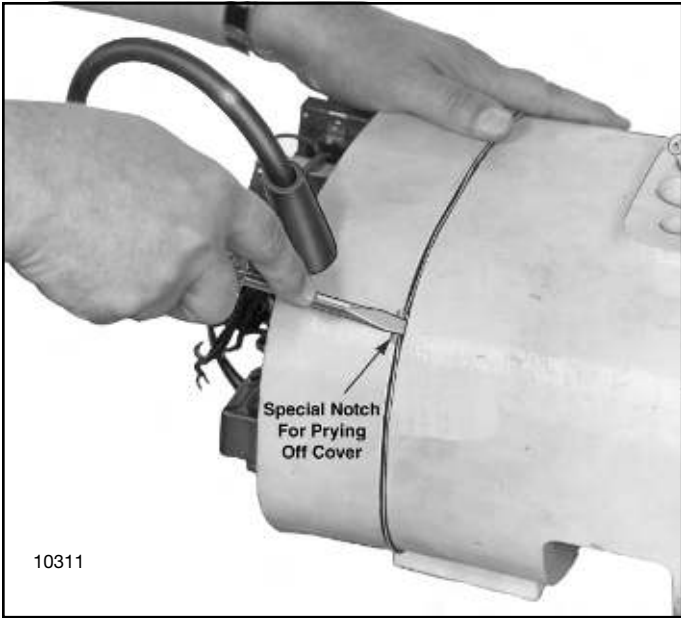

Figure 7-4. Prying Gear Case Cover from Hoist Frame

No Figure 7-5.

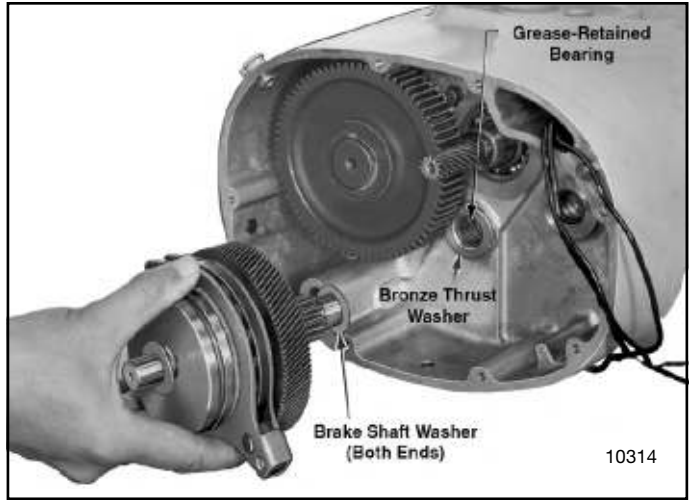

Figure 7-7. Removing Load Brake and Clutch Assembly (1/4 & 1/2 Ton Hoists)

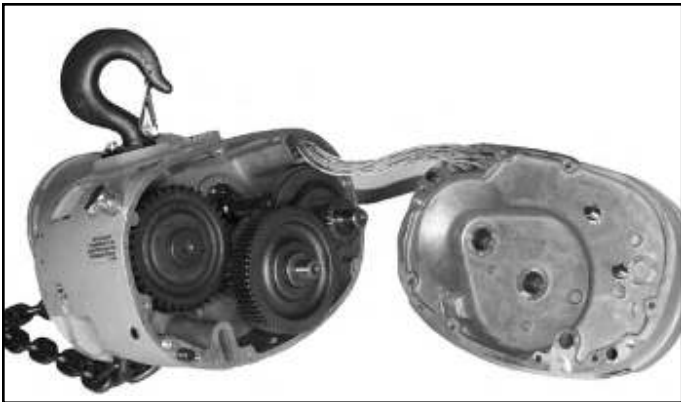

Figure 7-6. Gear Case Cover with Electrical Controls Removed from Frame

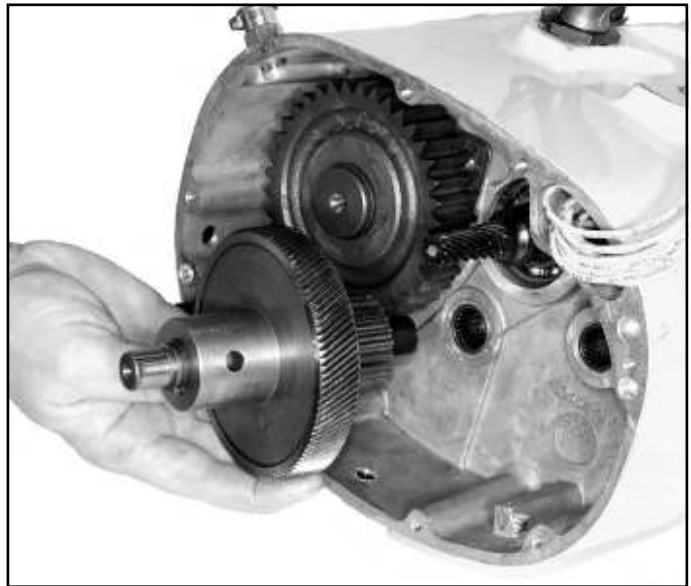

Figure 7-7a.

**c. Removal of Load Brake and Clutch Assembly and Intermediate Gear Subassembly.**

(1) On 1/4 through 1/2 ton hoists, pull load brake/clutch assembly if equipped or overload clutch assembly and the shaft washers from inside hoist frame (fig. 7-7). Caution: Grease-retained bearing has 36 rollers (all capacities) and may be reinstalled unless rollers are broken or missing or cup is damaged.

(2) On 1 through 3 ton hoists, pull load brake or clutch assembly and intermediate gear assembly, including the thrust washers for each unit, from hoist frame (fig. 7-8).



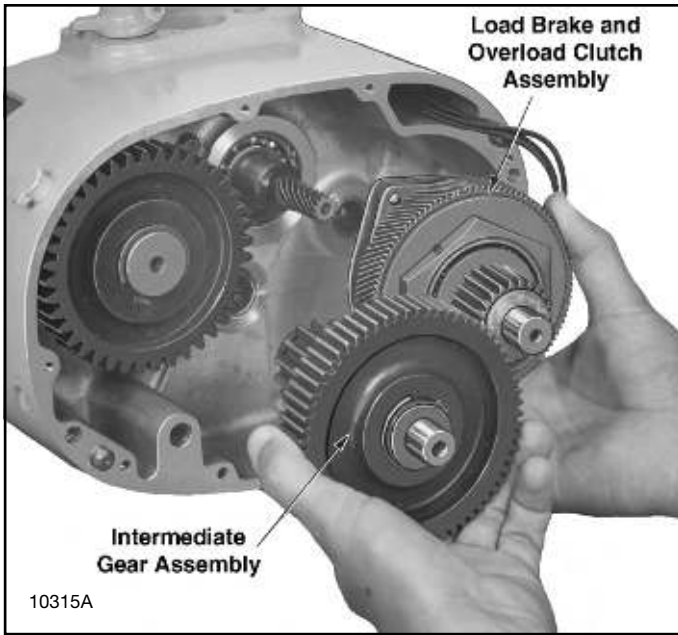

Figure 7-8. Removing Load Brake and Clutch and Intermediate Gear Subassemblies (1 through 3 Ton Hoists)



Figure 7-9. Removing Motor Assembly

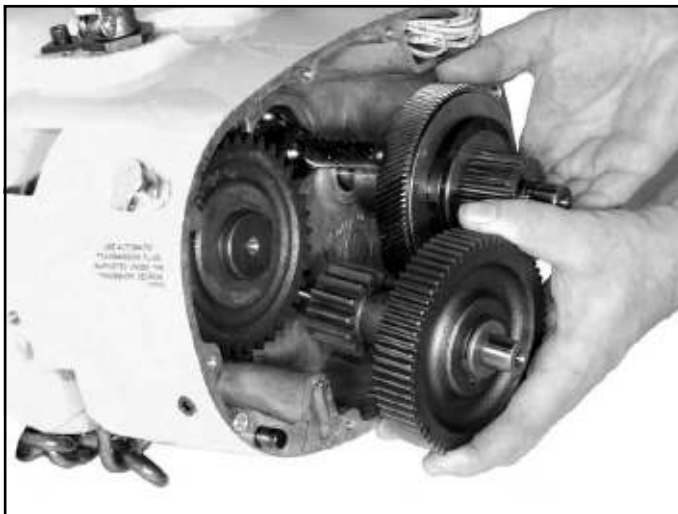

Figure 7-8a.

7-3. REBUILD OF HOIST FRAME, SPROCKET GEAR, SPROCKET SHAFT AND CHAIN GUIDE.

**a. Disassembly of Sprocket Gear, Shaft and Chain Guide.**

(1) Remove retaining ring from end of sprocket shaft and pull off sprocket gear using a common puller (fig. 7-10). Remove Woodruff key from shaft.

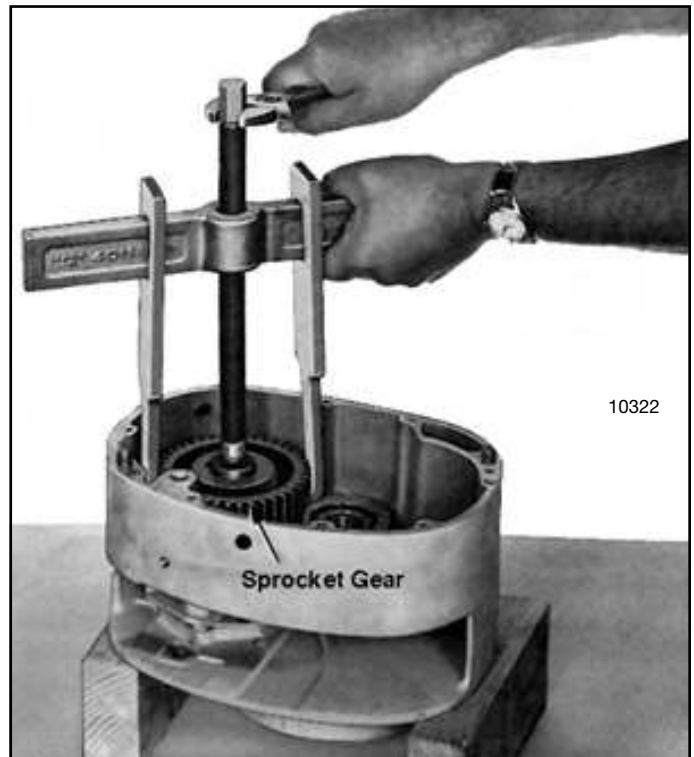

Figure 7-10. Pulling Sprocket Gear from Sprocket Shaft using Common Puller

**d. Removal of Motor Brake.**

(1) Remove acorn nuts holding brake cover and remove brake cover (fig. 7-11).

(2) Disconnect wire nuts on brake coil leads.

(3) Remove brake mounting plate screws (fig. 7-11) and lift brake assembly off to gain access to the motor mounting bolts.

**e. Removal of Motor Assembly.**

(1) Place hoist frame on wood blocks to protect intergral gear on motor shaft. Loosen four motor mounting bolts and lift motor assembly from frame (fig. 7-9). Guide motor leads through wire passage to avoid damage.

(2) Unscrew four fillister head machine screws securing sprocket bearing retaining plate and remove plate (fig. 7-11). Remove and discard ring gasket from groove around bearing.

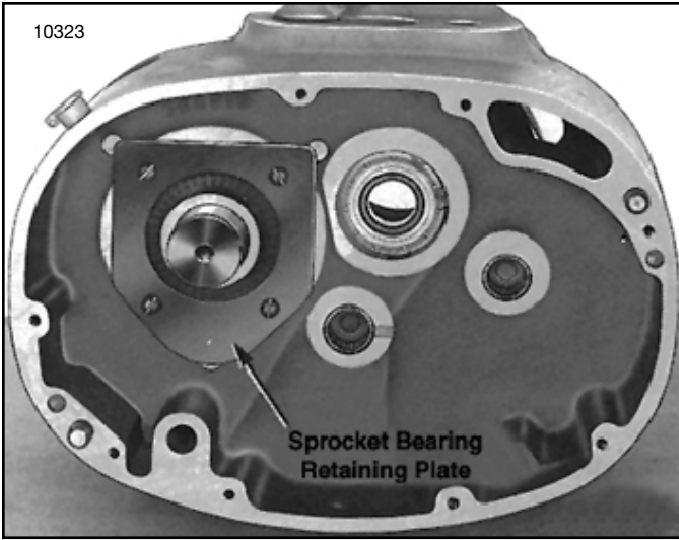

Figure 7-11. View of Sprocket Bearing Retaining Plate

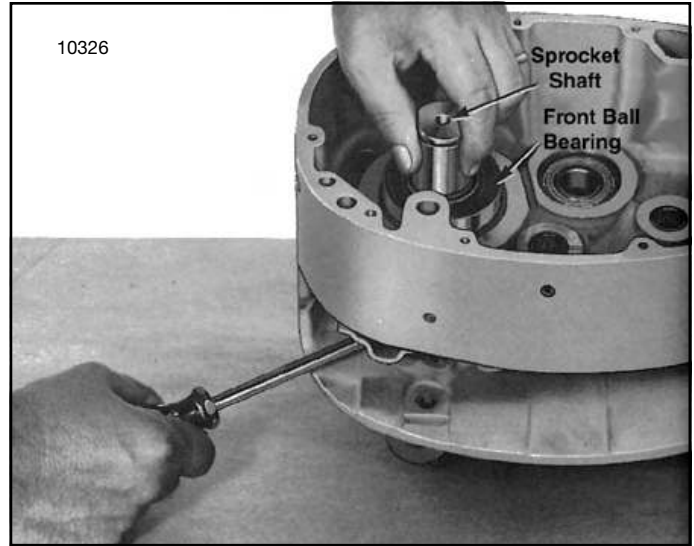

Figure 7-14. Removing Sprocket Shaft and Front Bearing

(3) Remove "C" clips holding chain guide pins in place. Pull guide pins out from motor side of frame. (Fig 7-13)

**NOTE:** Do not remove oil seal, ball bearings, and needle bearings from their bores in the frame unless they show evidence of wear or damage and require replacement. When replacing rear sprocket ball bearing pack bearing 1/2 full with NLGI No. 2 grease.



Figure 7-13. Removing Chain Guide Support Pins

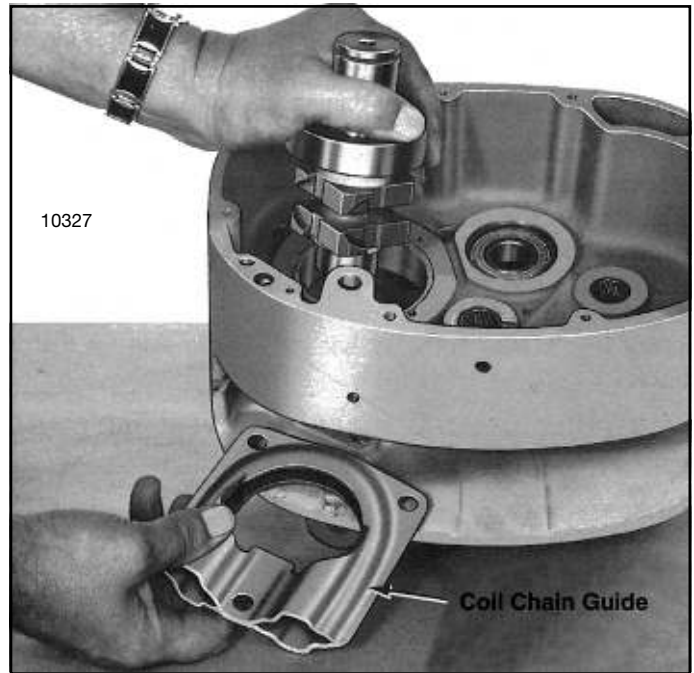

Figure 7-15. Chain Guide Being Removed from Frame as Sprocket Shaft is Lifted Out

(4) Remove sprocket shaft and front ball bearings assembly from frame by lifting up on end of shaft while prying up on sprocket as illustrated in figure 7-14. The chain guide will need to be repositioned in frame as sprocket shaft is raised to allow the sprocket to pass through hole of guide (fig. 7-15).

**b. Disassembly of Upper Hook. (Hook Suspension Models)**

(1) On 1/4 through 1 ton models, remove screw securing suspension bushing keeper. Unscrew suspension bushing from frame to remove hook.



Figure 7-18. Removing Upper Hook and Hook Nut from Hoist Frame (1/4 through 1 Ton Models)

(2) On 2 ton models, unscrew two hex socket head screws holding suspension bushing lock assembly to upper block (fig. 7-19) and remove lock. Unscrew suspension bushing from block to remove hook. To disassemble block from frame, remove screw securing suspension bushing keeper. Remove drive pin securing threaded end of chain anchor in block and unscrew anchor. Unscrew suspension bushing to remove block.



Figure 7-19. View of Upper Hook Assembled to Hoist Frame (2 Ton Models)

**NOTE:** Hook and bushing assembly is not to be further disassembled as nut securing bushing to hook shank is welded in place at the factory. Only the assembly is available for replacement.

(3) On 3 ton models, remove retaining ring from connecting rod pin and push connecting rod pin through bracket and connecting rod, releasing hanger (see fig. 7-2). Raise hanger above hoist frame to provide access to hook nut. Rotate hook until grooved pin in nut is visible from end of hanger frame. Using a drift punch,

drive grooved pin through hook nut until it hits hanger pocket. Remove drift far enough to hold nut from turning and unscrew hook from nut. Thrust washer will fall free.

(4) To remove connecting rod (fig 7-2) on 3 ton hoist, remove screw securing suspension bushing keeper. Unscrew suspension bushing to remove connecting rod from frame.

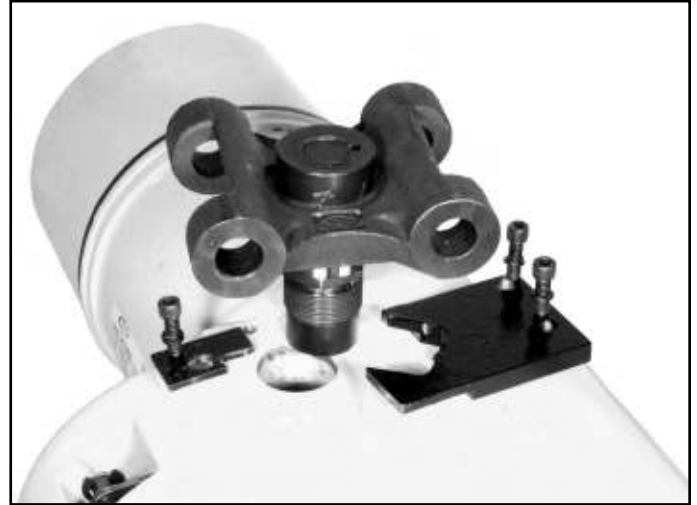

Figure 7-20. Removing Suspension Lug (1/4 through 1 Ton Models)

**c. Disassembly of Suspension Lug (Lug Suspension Models).**

(1) On 1/4 through 1 ton models, remove two screws securing anti-rotation bracket and remove bracket. Remove screw securing suspension bushing keeper, and remove keeper. Remove suspension lug using an extra thin 1-1/4" open end wrench to unscrew suspension bushing from frame. (See fig. 7-20).

(2) On 2 ton models, remove three hex socket head screws securing the two lock plates to block at top of frame and pull out locks. Remove suspension lug, using an extra thin 1-1/4" open end wrench to unscrew suspension bushing from block. Instructions for removing block from frame are given in paragraph b. (2).

**NOTE:** The suspension lug is not to be further disassembled, as nut securing suspension bolt and bushing to lug is permanently secured in place at the factory. Only the suspension lug assembly is available for replacement.

(3) On 3 ton models lug bolt is removed in same manner as hook. See paragraph 7-3. b. (3).

**d. Reassembly.**

(1) Before assembly, all parts should be thoroughly cleaned and inspected to determine their serviceability. Replace parts that are excessively worn or damaged.

(2) Reassemble suspension hook or lug, chain guide, sprocket shaft and sprocket gear to frame following a reverse procedure of the disassembly steps listed in paragraphs (a.) through (c.), above. If ball bearing is to be reinstalled on sprocket be certain to position it so that the seal side of bearing faces out, away from sprocket. To help prevent oil seepage, apply sealant on O.D. of sprocket bearing and in seat for the ring gasket.

7-4. REBUILD OF LOAD BRAKE AND OVERLOAD CLUTCH ASSEMBLY. (If hoist is equipped with overload clutch less load brake, see 7-4A.)

a. Disassembly.

(1) Place load brake and clutch assembly, flange up, in a vise equipped with brass or copper jaw plates to protect pinion gear teeth. Remove snap ring of load brake shaft (fig. 7-21).

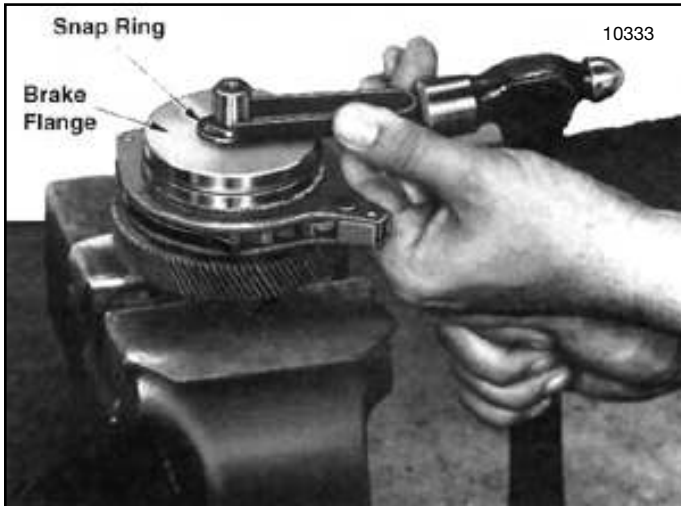

Figure 7-21. Removing Snap Ring from Load Brake Shaft

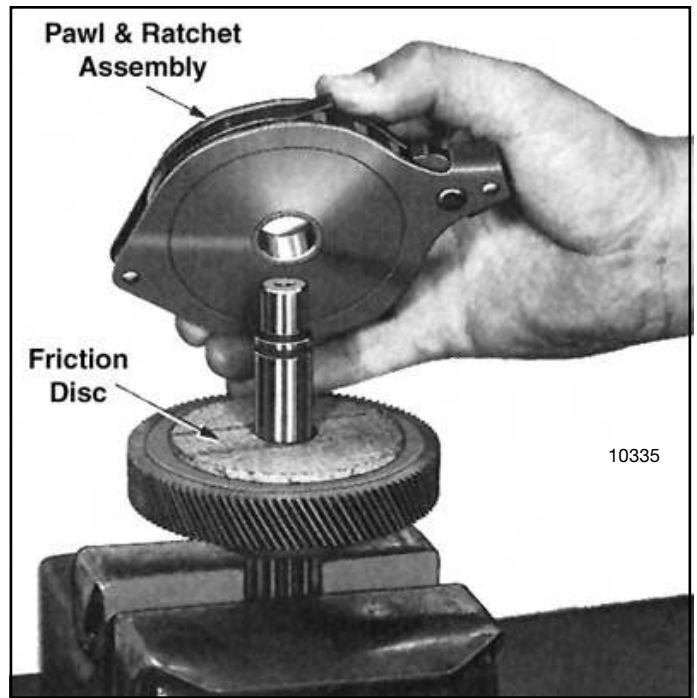

Figure 7-23. Removing Pawl and Ratchet Assembly from Load Brake Shaft

(3) Remove load brake gear and overload clutch assembly from output pinion shaft. Pull the spring from its recess in clutch cone (fig. 7-24) but do not further disassemble gear and clutch assembly. See "NOTE" below.

**NOTE:** Disassembly of the load brake gear and overload clutch assembly (fig. 7-24) is not recommended. Clutch pressure is preset by the factory at assembly to provide the correct torque to allow the clutch to refuse loads within a specified range (150% of rated load to 200% rated load). It is suggested whenever there is a need to repair or readjust the gear and clutch assembly that it be sent to an authorized **Budgit** Hoist Repair Station where adequate tools, fixtures and appropriate test equipment is available.

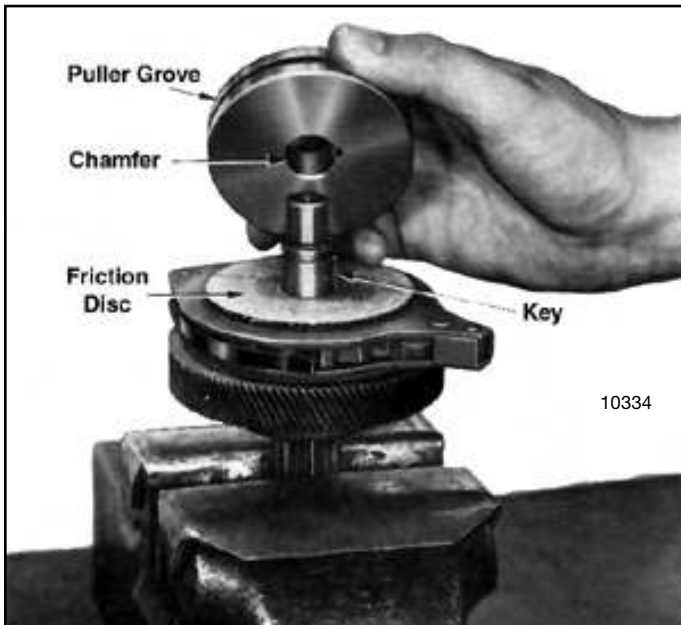

Figure 7-22. View Showing Load Brake Flange Removed

(2) Using a puller tool, remove brake flange from shaft. A groove is provided around outer diameter for this purpose. See figure 7-22. Remove key from shaft and lift off 2 friction discs, and the pawl and ratchet assembly (fig. 7-23).

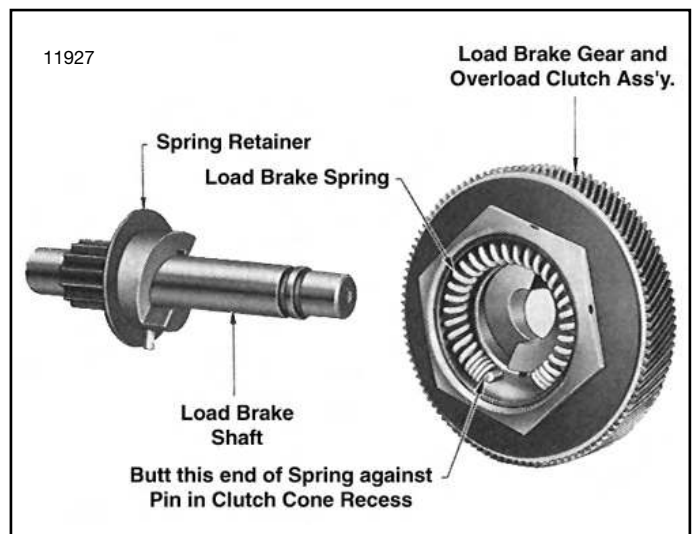

Figure 7-24. Load Brake Gear and Overload Clutch Assembly Removed from Load Brake Shaft Showing Brake Spring Installed in Clutch Cone

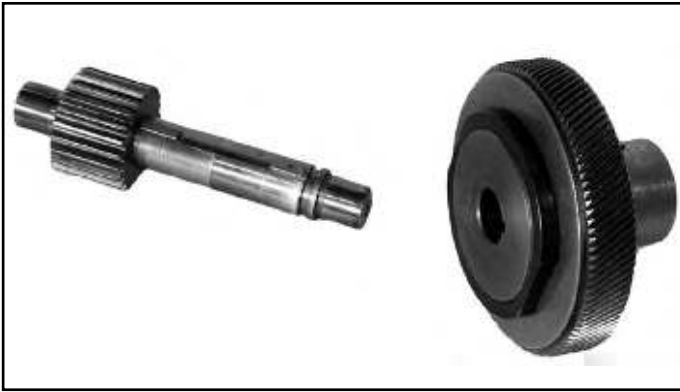

Figure 7-24a.

(4) The load brake pawl and ratchet is a riveted assembly and is not to be disassembled.

#### b. Reassembly.

(1) Before assembly, all parts should be cleaned and inspected to determine their serviceability. Replace parts that are worn or damaged.

(2) Reassemble load brake parts following a reverse procedure of the disassembly steps listed above, observing the assembly steps (3) through (6) below.

(3) Before installing spring in its recess in center of clutch cone (fig. 7-24) apply a good grade of ball bearing grease to inside of recess. Spring must be positioned exactly as illustrated, abutted against pin.

(4) When installing pawl and ratchet assembly on load brake shaft, be certain that teeth on ratchet face are in the same direction as shown in fig. 7-23. The ratchet assembly should rotate freely when turned counterclockwise and the pawl should engage ratchet teeth when unit is turned clockwise.

(5) When installing brake flange position it with chamfer facing friction disc, figure 7-22.

(6) The brake spring must be pre-loaded at assembly to a torque of from 6 to 10 lb. ft. when used with yellow (color code) spring and a torque of 10 to 14 lb. ft. when used with plain (no color code) spring. (See Section IX for proper spring). This is accomplished using a plumber's strap wrench to wind (rotate) load brake gear to set up spring (fig. 7-25) while pressing brake flange into place using an arbor press. Clamp pinion end of shaft into a portable vice to keep brake from rotating in press. Use brass or copper jaw plates on vise to protect pinion gear teeth. Wind gear counterclockwise (viewing brake from flange end) with strap wrench and press down on flange until snap ring groove in shaft is exposed allowing snap ring to be installed. Use extreme care not to over wind spring as yield will result and final spring torque will be reduced. Do not wind gear beyond point necessary to install snap ring in groove.

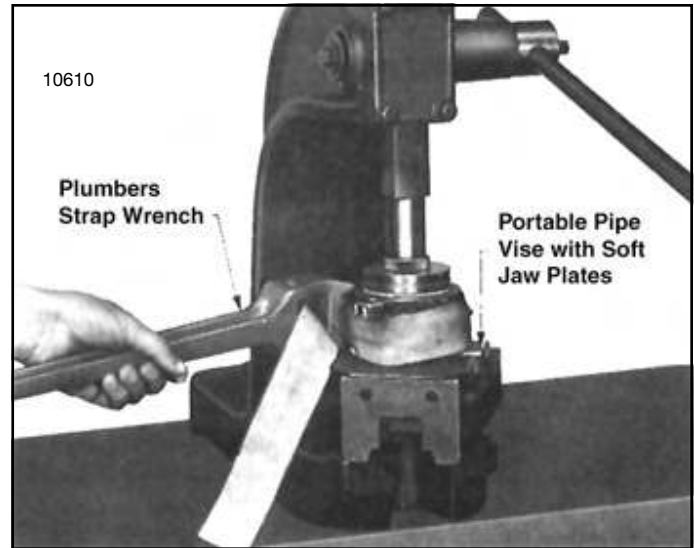

Figure 7-25. Winding Load Brake Gear  
Using a Strap Wrench to Set Up Load Brake Spring

#### 7-4A. OVERLOAD CLUTCH WITHOUT LOAD BRAKE.

Disassembly of the clutch gear and overload clutch assembly (fig 7-24a) is not recommended. Clutch pressure is preset at the factory at assembly to provide the correct torque to allow the clutch to refuse loads within a specified range (150% of rated load to 200% rated load). It is suggested whenever there is a need to repair or readjust the overload clutch assembly that it be sent to an authorized Budget Hoist Repair Station where adequate tools, fixtures, and appropriate test equipment is available.

#### 7-5. REBUILD OF LOWER BLOCK AND LOAD CHAIN ASSEMBLY.

##### a. Disassembly (1/4 through 1-ton, single reeved models).

(1) Separate load chain from lower block assembly. Drive out small roll pin securing lower block pin in lower block yoke and push lower block pin from yoke to release chain.

(2) Drive grooved pin from limit actuator and pull actuator from end of chain.

(3) Lower blocks are of a pinned construction, permitting replacement of body, thrust bearing, or hook and nut assembly. To disassemble, drive spring pin from hook nut (fig. 7-26). With pin removed, hold hook nut from turning with drift punch and rotate hook to unscrew it from nut.



Figure 7-26. Removing Roll Pin Securing Hook Nut to Hook Shank



Figure 7-28. Removing Sprocket Pin Lock on 2 through 5 Ton Lower Block Assembly

(4) Separate hook, bearing shield, needle bearings and two thrust washers from body. Hook and nut are drilled at assembly and are replaced only as an assembly.

**b. Disassembly** (2-ton, double reeved models).

(1) Remove fillister head screw securing center guide in top of lower block body and lift out guide (fig. 7-27) and sprocket pin lock (fig. 7-28). Press sprocket pin from body and pull out chain, sprocket and washer (fig. 7-29). Do not remove bushing type bearing from sprocket or pressure lube fitting from sprocket pin unless replacement is necessary.



Figure 7-29. Removing Coil Chain and Sprocket on 2 through 5 Ton Lower Block Assembly (Link Chain Model)

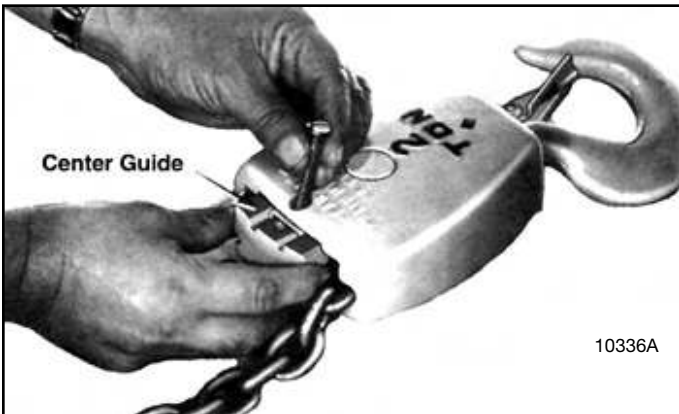

Figure 7-27. Removing Chain Center Guide from 2 through 5 Ton Lower Block Assembly

(2) To disassemble hook and nut, drive groove pin from hook nut with drift punch. With pin removed, hold hook nut from turning with drift punch and rotate hook to unscrew it from nut. Separate hook, nut, bearing shield, needle bearing and two thrust washers from body. Hook and nut are drilled at assembly and are replaced only as an assembly.

**c. Disassembly** (3-ton, triple reeved models).

(1) Remove chain sprocket from lower block following procedure for 2-ton link chain models described in paragraph 7-5. b. (2) above.

(2) To disconnect end of chain anchored to lower block, remove retaining ring from pin bore (fig. 7-30). Push connecting link pin from bore by pressing through hole provided in opposite side of block (fig. 7-31). Chain connecting link is now free and can be further disassembled for inspection.

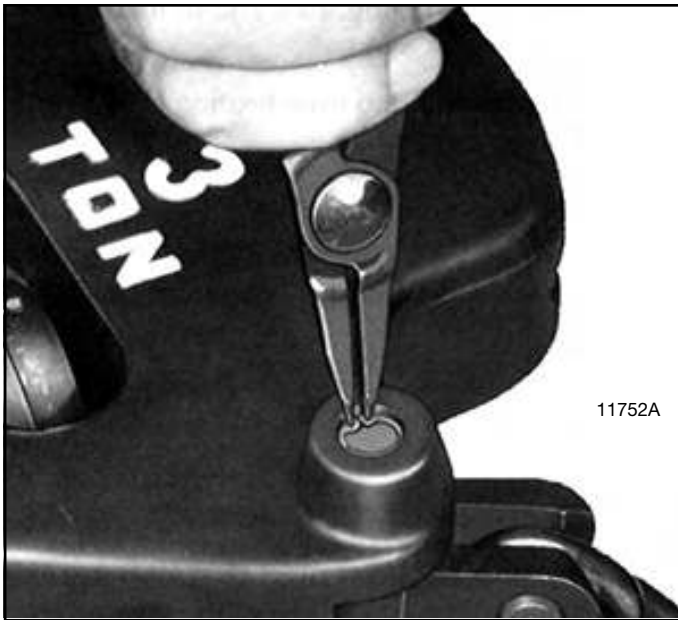

Figure 7-30. Removing Retaining Ring from Bore of Connecting Link Pin - 3 Ton Lower Block Assembly

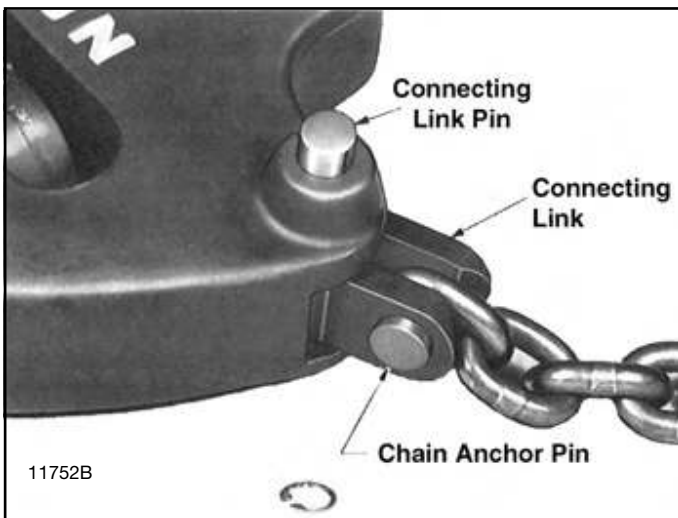

Figure 7-31. Removing Connecting Link Pin from 3 Ton Lower Block Assembly

(3) To remove hook from lower block body, first drive grooved pin from hook nut. Then hold nut from turning using drift punch and rotate hook to unscrew it from nut. Separate hook, shroud and thrust washer from body. Note that bearing surface of washer faces nut.

(4) To remove chain sprocket from upper suspension hanger, first remove hanger as outlined in paragraph 7-2. a. (4). With hanger removed, push sprocket pin from hanger and sprocket. **NOTE:** Sprocket pin must be removed toward side having small anti-rotation pin slot in hanger.

**d. Reassembly of Lower Blocks.**

- (1) Clean, inspect and replace worn or damaged parts.
- (2) Lubricate and reassemble following a reverse procedure of the disassembly steps above.

**7-6. REBUILD OF ELECTRICAL CONTROLS AND GEAR CASE COVER SUBASSEMBLY.**

**a. Disassembly.**

- (1) Disconnect two limit switch leads from contactor. Also, if hoist has a transformer, disconnect transformer leads at the contactor or terminal board.
- (2) Remove reconnectable terminal board if so equipped.
- (3) Remove two screws and lift transformer from gear case cover if hoist is so equipped.
- (4) Remove two screws attaching contactor assembly to cover and lift off contactor. Refer to paragraph 7-8 for instructions for rebuild of contactor assembly.
- (5) Remove two hex socket head screws and lockwashers securing limit switch assembly to gear case cover and pull limit switch assembly and control shaft from cover.
- (6) Loosen two nuts and screws holding limit switches to retainer bracket and remove.
- (7) Remove self-locking nut from end of control shaft and pull off washer, switch activator, centering lever, spring, spacer tube, retainer bracket and washer.

**NOTE:** Do not remove needle bearings from gear case cover unless they show evidence of wear or damage and require replacement.

**b. Reassembly.**

- (1) Before assembly, all parts should be thoroughly cleaned and inspected to determine their serviceability. Replace parts that are worn or damaged.
- (2) Reassemble parts to gear case cover in reverse of the disassembly steps above. Ends of centering spring must straddle centering levers. Lubricate contact segments of limit switch with small amount of graphite grease.

**7-7. REBUILD OF PUSH BUTTON STATION AND CONDUCTOR CABLE ASSEMBLY.**

**a. Disassembly.**

- (1) Remove seven pan head machine screws and lockwashers from back of push button station and lift off rear cover.
- (2) Loosen three terminal screws and remove strain cable screw, lockwasher and plain washer.
- (3) Remove two pan head machine screws and lockwashers from housing cap and remove cap, grommet and cable assembly.
- (4) Remove two pan head screws, contact assembly and button assembly.

**b. Reassembly.**

- (1) Before assembly, all parts should be thoroughly cleaned and inspected to determine their serviceability. Replace all parts that are worn or damaged.
- (2) Reassemble push button station and conductor cable following a reverse procedure of the disassembly steps listed above.

**NOTE:** Do not attempt to shorten or lengthen push button conductor cable. Odd length conductor cable assemblies for other than standard 10 ft. lift hoists can be procured from the factory.

#### 7-8. REBUILD OF CONTACTOR ASSEMBLY.

**a. General.** Wear or damage to contactor parts requires replacement of complete contactor assembly.

#### 7-9. REBUILD OF SINGLE PHASE MOTOR ASSEMBLY.

##### a. Disassembly.

(1) To inspect capacitor, remove two cover mounting screws and lift off capacitor cover. Do not disconnect wires at capacitor unless capacitor must be replaced.

(2) Remove external retaining ring from end of shaft and press shaft out of bearing in end bell.

(3) Remove motor end bell from stator assembly. If necessary loosen it by tapping with soft mallet.

(4) Remove internal retaining ring from bearing bore in end bell and press out bearing assembly.

##### b. Reassembly.

(1) Before assembly, all parts should be cleaned and inspected to determine their serviceability. Replace all parts that are worn or damaged.

(2) Reassemble motor following a reverse procedure of the disassembly steps listed above.

(3) After reinstalling hoist motor, connect hoist to power supply and carefully complete both checks (a) and (b) below:

(a) To check direction of rotation, briefly operate "↑" button. If hook lowers, interchange motor lead "T1" with "T4" at the contactor or controller. Hook must raise when the "↑" push button is operated.

(b) To check the starting winding switch, connect ammeter (minimum 10 ampere) to motor lead "T5". Amperes must drop to zero in approximately one second when operating hoist in both "↑" and "↓" directions. If ampere reading does not drop to zero, interchange motor leads "T7" and "T8". If, after above checks were made with motor having been run in both directions, the ammeter reading still does not return to zero, the motor switch is not functioning properly and should be replaced.

### **⚠ WARNING**

**Do not change circuit wiring. Severe damage and malfunction of hoist may result.**

#### 7-10. REBUILD OF THREE PHASE MOTOR ASSEMBLY.

##### a. Disassembly.

(1) Pull four motor mounting bolts from motor and separate stator assembly from the end bell and rotor shaft assembly.

(2) Remove external retaining ring from end of motor shaft and press shaft from bearing in end bell.

(3) Remove internal retaining ring from bearing bore in end bell and press out bearing assembly.

##### b. Reassembly.

(1) Before assembly, all parts should be cleaned and inspected to determine their serviceability. Replace all parts that are worn or damaged.

(2) Reassemble motor following a reverse procedure of the disassembly steps listed above.

#### 7-11. REASSEMBLY OF HOIST FROM SUBASSEMBLIES.

**a. General.** The procedure to be followed to reassemble the hoist from subassemblies is in reverse order of the disassembly steps outlined in paragraph 7-2. Listed below are special assembly precautions which should be observed to assure proper assembly.

**NOTE:** Grease retained bearings (see Section VII, par. 7-2.

c. (1) and fig. 7-7) have loose rollers. When reassembling hoist, make certain the correct number of rollers are held in roller cup with grease before assembling load brake shaft to hoist.

**b. Assembly of Load Brake Thrust Washers.** When reinstalling load brake assembly be certain thrust washers are properly installed at both ends of load brake shaft, as noted below.

(1) A bronze thrust washer with a lug on one side belongs on pinion end of shaft and must be installed so that its lug engages the special slot located on spotface surrounding bearing bore inside hoist frame or gearcase cover. Use heavy grease to hold washer in proper position in frame or cover (depending upon hoist capacity) during assembly.

(2) A 5/8" I.D. steel thrust washer is to be installed on the brake flange end (end opposite pinion) of load brake assembly.

**c. Motor Brake.** Check brake adjustment after first 30 days of service and regularly thereafter during the six-month inspection procedure.

#### **Installation and Service Instructions for 54,000 Series (rev. A) Manual Adjust Brakes.**



**Important** - Please read these instructions carefully before installing, operating, or servicing. Failure to comply with these instructions could cause injury to personnel and/or damage to property if the brake is installed or operated incorrectly.



**Caution**

1. Installation and servicing must be made in compliance with all local safety codes including Occupational Safety and Health Act (OSHA). All wiring and electrical connections must comply with the National Electric Code (NEC) and local electric codes in effect.

2. To prevent an electrical hazard, disconnect power source before working on the brake. Lock disconnect in the off position and tag to prevent accidental application of power.

3. Be certain power source conforms to the requirements specified on the brake nameplate.

4. Be careful when touching the exterior of an operating brake. Allow sufficient time for brake to cool before disassembly. Surfaces may be hot enough to be painful or cause injury.

5. Do not operate brake with housing removed. All moving parts should be guarded.

6. After usage, the brake interior will contain burnt and degraded friction material dust. This dust must be removed before servicing or adjusting the brake.

DO NOT BLOW OFF DUST using an air hose. It is important to avoid dispersing dust into the air or inhaling it, as this may be dangerous to your health.

- a) Wear a filtered mask or a respirator while removing dust from the inside of a brake.
- b) Use a vacuum cleaner or a soft brush to remove dust from the brake. When brushing, avoid causing the dust to become airborne. Collect the dust in a container, such as a bag, which can be sealed off.

**General Description** - This series brake is spring set, electrically released. These brakes will contain one or two friction discs driven by a hub mounted on the motor.

**Operating Principle** - When the brake coil is energized the lever arm retracts the spring force from the disc pack, allowing the friction disc to rotate with the hub and motor shaft. When power is removed the lever arm pushes down on the stationary disc and friction discs. The hub is held from rotating, and the load is held in place.

** WARNING**

**Do not release brake if there is a suspended load on the hoist hook.**

**Manually releasing the brake will allow a suspended load to fall, possibly causing damage, injury or death.**

**Weight of load chain may be sufficient to cause entire chain to run through hoist if brake is released. Be sure chain is secured.**

**Always be certain any suspended load (which includes below the hook devices or attachments) are removed before servicing, adjusting or removing brake.**

**If chain is moved causing rotation of the sprocket without the electronic limit switch powered, check upper and lower limit settings before resuming normal operation.**

**NOTES**

---



---



---



---



---



---



---



---



---



---



---

# BRAKE MOUNTING PROCEDURE

① Place hub on motor shaft.

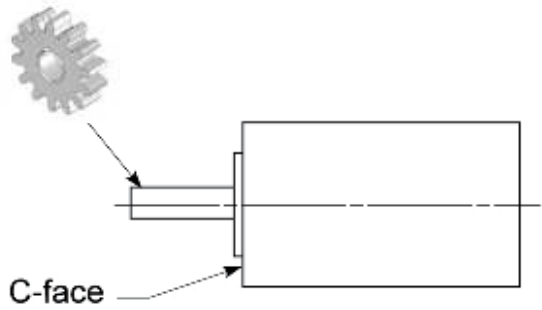

② Apply Loctite 680 to set screws. Tighten set screws on motor shaft.

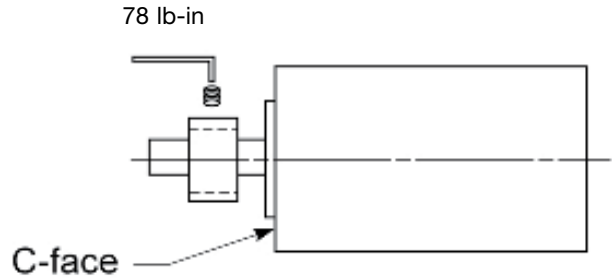

③ Remove brake housing and gasket.

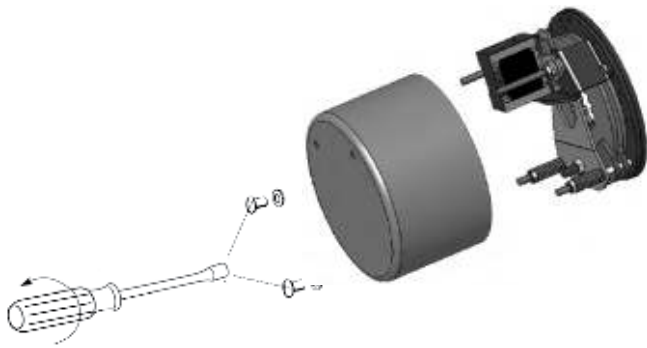

④ Align friction disc with splined hub and slide brake against motor face.

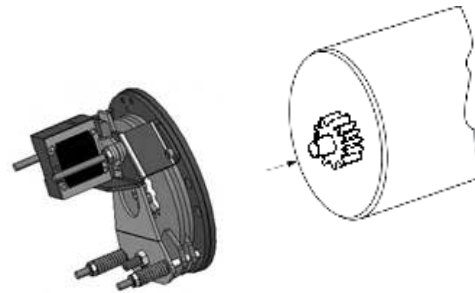

⑤ Insert mounting screws and tighten.

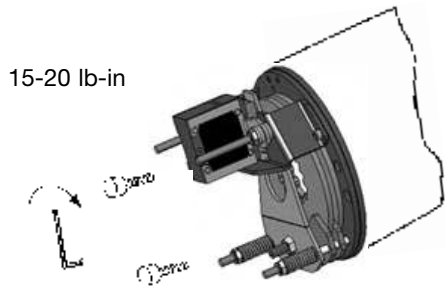

⑥ Connect coil leadwires to power supply. Refer to nameplate for voltage rating.\*  
**Caution:** Keep wiring away from pinch points and moving components.

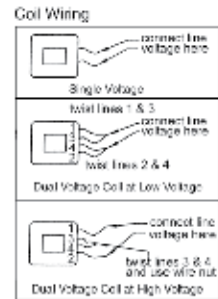

⑦ Replace brake housing and tighten to 8 lb-in.

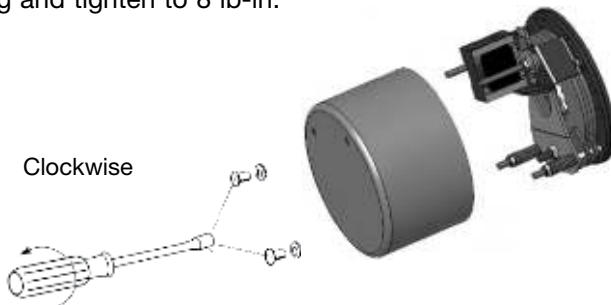

**Air Gap Adjustment**

Brake air gaps are factory adjusted to .100". As friction discs wear the air gap will increase. When the gap reaches .200" it will need to be readjusted to .100".

1. Loosen jam nut (10N).
2. Turn adjusting screw (10) CW until .100" gap is reached (see Fig. 1).
3. Retighten jamb nut.
4. Check air gap again.

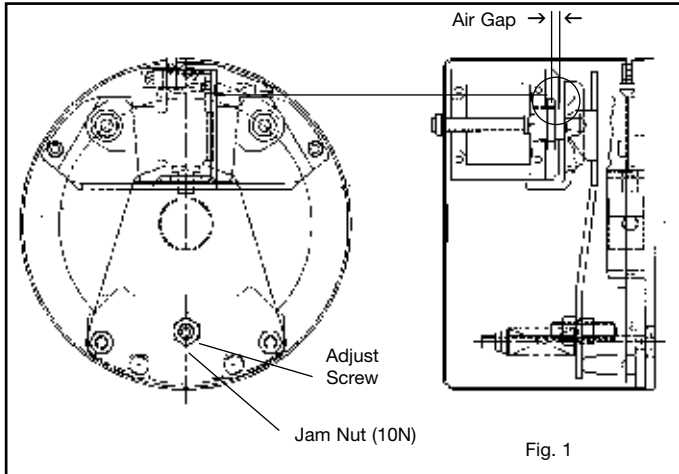

**Torque Adjustment**

The brake is factory set for nominal rated torque. No further adjustment to increase torque may be made. The approximate compressed torque spring height is shown below. Torque reduction may not exceed 1 full turn in the CCW direction (1.5 lb-ft brake cannot be reduced). Note that the spring measurement for the 6 lb-ft spring is from inside the shoulder washer.

| Brake Torque (lb-ft) | Length "L" (in.) | Max Torque Reduction (ccw turn of torque nut) | % Reduction |
|----------------------|------------------|---|-------------|
| 1.5                  | 1.102            | 0   | 0           |
| 3                    | .954             | 1   | 15          |
| 6                    | 1.286            | 1   | 25          |

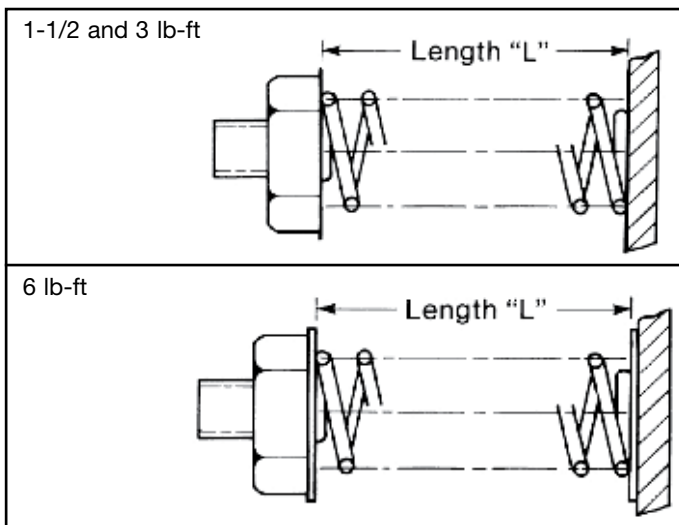

**Friction Disc Replacement**

Friction disc(s) should be replaced when the wear area is 3/32" thick or less.

1. Remove the two brake mounting screws and lift the brake assembly from the hub / motor.
2. Remove the two support bracket screws (35), and lift the brake and solenoid assembly (3) off the brake.
3. Lift the lever arm (17) forward and slide the friction disc(s) out of the brake assembly.
4. Insert new friction disc(s) under the stationary disc (5). If brake has two friction discs align the center spline holes with each other.
5. Align the brake and friction disc assembly on the hub (16) and slide onto the motor. Insert and tighten the two brake mounting screws (15-20 lb-ft).
6. Reposition the support bracket assembly (3) on the brake, and retighten the two support bracket screws (35), (52 lb-in).

**Note:** Air gap readjustment will be required after disc replacement.

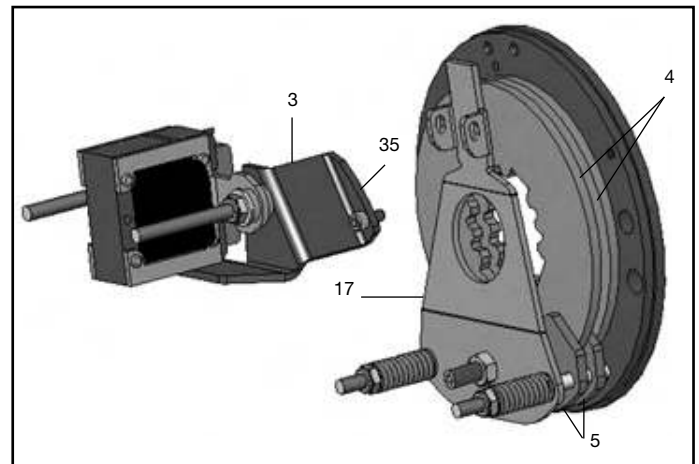

**Coil Replacement**

1. Remove the two support bracket screws (35), and lift the bracket and solenoid assembly (3) off the brake.
2. Remove the plunger guide (140) from the inside of the coil.
3. Remove the thru-bolt (160) from the leadwire side of the coil by backing off the lock-nut (210). Slide the bolt, shock mount pads and flat washer out of the way.
4. Remove the coil (12) from the solenoid frame (79) by pushing down on the coil locking tab on the side opposite the leadwires. Push the coil out of the frame.
5. Insert the new coil into the solenoid frame in reverse of the steps of removal. Insert the new plunger guide (140) into the coil, locking tabs first.
6. Position a shock mount pad (150) on both sides of the solenoid mounting bracket, and reinsert the thru-bolt (160) through the shock pads and bracket.
7. Slide a flat washer (170) over the bolt, and tighten the locknut down until the shock pads begin to flatten.

8. Position the solenoid and bracket assembly (3) over the plunger (29) and slide into place. Tighten the bracket mounting screws (35) to 52 in-lb.
9. Reassemble brake motor by following steps 5-7 of the brake mounting procedure.

9. Position the solenoid and bracket assembly (3) over the plunger (29) and slide into place. Tighten the bracket mounting screws (35) to 50 in-lb.
10. Reassemble brake to motor by following steps 5-8 of the brake mounting procedure.

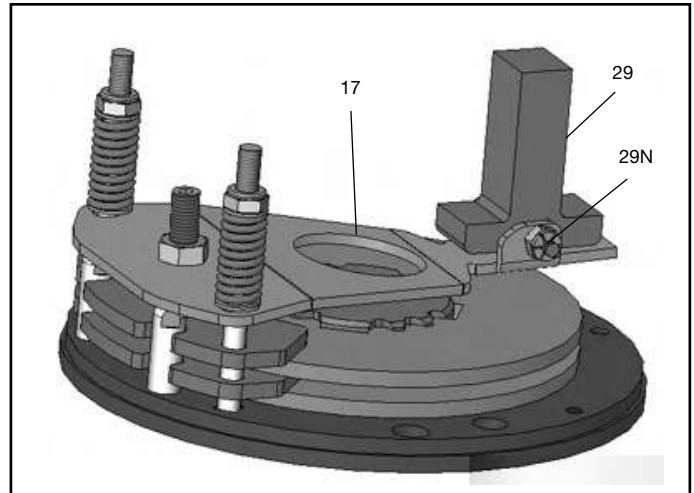
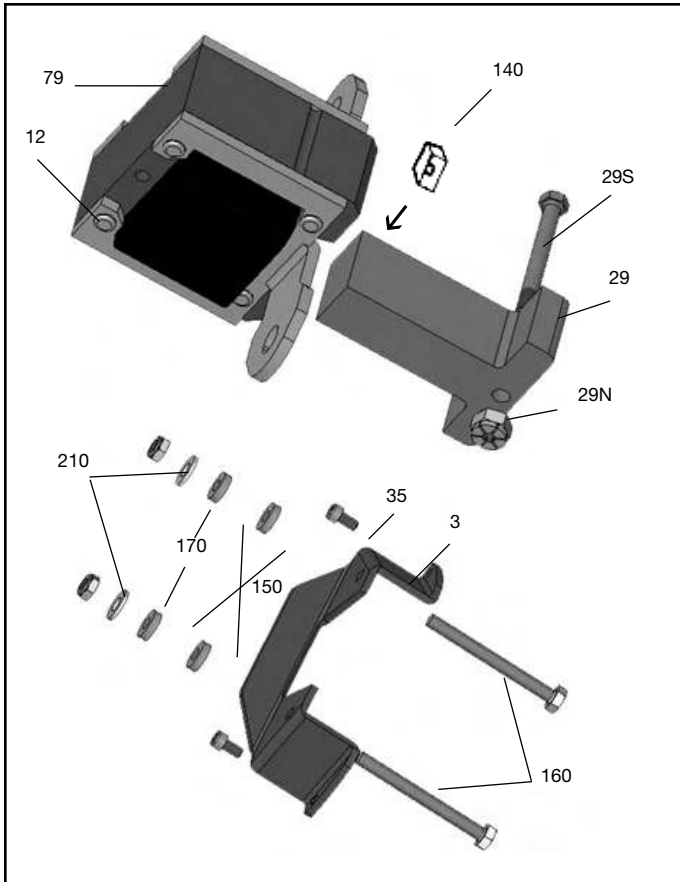

### Solenoid Replacement

1. Remove the two support bracket screws (35), and lift the bracket assembly (3) off the brake.
2. Remove the plunger guide (140) from the inside of the coil.
3. Remove both thru-bolts (160) from the solenoid assembly (79).
4. Remove the coil (12) from the solenoid frame (79) by pushing down on the coil locking tab on the side opposite the leadwires. Push the coil out of the frame.
5. Insert the coil into the new solenoid frame in reverse of the steps of removal. Insert the new plunger guide (140) into the coil, locking tab first.
6. Position the new shock mount pad (150) on both sides of the solenoid mounting bracket, and reinsert the tap-bolts (160) through the shock pads and bracket.
7. Slide the flat washers (170) over the bolt, and tighten the locknut down until the shock pads begin to flatten.
8. Remove the plunger nut (29N) and screw (29S), and lift plunger (29) from lever arm (17). Install the new plunger to the lever arm using the new screw and nut provided. Tighten to 40 in-lb.

| TROUBLESHOOTING  |  |   |  |
|--|--|---|--|
| Coil Failure   |  | Excessive Wear/Overheating  |  |
| Supply Voltage Cause   | Supply Voltage Correction  | Air Gap Cause   | Air Gap Correction   |
| Line voltage >110% of coil rating  | Reduce voltage or replace with proper rated coil                                     | Low solenoid air gap  | Reset air gap (refer to Air Gap Adjustment)                            |
| Excessive voltage drop during inrush time  | Increase current rating of power supply  | Cycle Rate Cause  | Cycle Rate Correction  |
| Wiring Cause   | Wiring Correction  | Brake "jogging" exceeding coil cycle rate   | Reduce cycle rate or consider alternate control method                 |
| Leadwires interfering with plunger pull-in   | Reroute wiring away from plunger and other moving components                         | Thermal capacity is being exceeded  | Reduce cycle rate, use alternate control method or increase brake size |
| Coil leadwire shorted to ground  | Replace coil or leadwire and protect with wire sleeving                              | Alignment Cause   | Alignment Correction   |
| Solenoid Assembly Cause  | Solenoid Assembly Correction   | Brake endplate not concentric to motor C-Face                                     | Motor resister must be within .004" on concentricity                   |
| Plunger not seating flush against solenoid frame   | Loosen solenoid mounting nuts and reposition frame to allow full face contact        | Motor shaft runout is excessive   | Must be within .002"; runout; consult motor manufacturer               |
| Excessive solenoid/plunger wear at mating surface  | Replace solenoid assembly  | Worn Parts Cause  | Worn Parts Correction  |
| Broken shading coils   | Replace solenoid assembly  | Friction disc excessively worn (disc can wear to 1/2 original thickness or .093") | Replace friction discs   |
| Worn Parts Cause   | Worn Parts Correction  | Endplate, stationary disc or pressure plate warped                                | Replaced warped or worn component                                      |
| Excessive wear of solenoid link bolt   | Replace link bolt; also inspect plunger thru-hole for elongation                     | Linkages worn   | Replace all worn components  |
| Plunger guide worn down and interfering with plunger movement                                | Replace guide  | Motor shaft endfloat excessive  | Endfloat must not exceed .020"; consult motor manufacturer             |
| Application Cause  | Application Correction   | Hub Cause   | Hub Correction   |
| Machinery cycle rate is exceeding brake rating   | Reduce brake cycle rate or use alternate control method                              | Burr on hub interfering with disc "float"   | File off burr  |
| High ambient temperature (>110° F) and thermal load exceeding coil insulation rating         | Use Class H rated coil and/or find alternate method of cooling brake                 | Set screw backed out and interfering with disc                                    | Retighten set screw; use Loctite® 680 to help secure                   |
| Brake coil wired with windings of an inverter motor or other voltage/current limiting device | Wire coil to dedicated power source with instantaneous coil rated voltage            | Miscellaneous   | Miscellaneous  |
| Miscellaneous Cause  | Miscellaneous Correction   | Wiring is restricting disc pack movement  | Reroute wiring   |
| Wrong or over tightened torque springs   | Replace with proper spring or refer to installation section for proper spring height | Excessive stop time (2 seconds or greater)  | Increase brake size/torque or use alternate control method             |
| Excessive air gap  | Reset, refer to Airgap Adjustment  | High Ambient temperature (in excess of 110°F)                                     | Reduce cycle rate or use alternate method of cooling                   |

**d. Assembly of Load Chain.**

**NOTE:** Coil chain must be installed so welds on vertical links face away from the load sprocket.

(1) Install load chain over sprocket before load brake assembly is installed. Insert anchor end of chain (end opposite lower block on single reeved models) into chain guide opening on far side of hoist (viewing frame from anchor screw side). Rotate sprocket gear by hand counterclockwise as chain is fed into opening. When sufficient chain has been run into hoist to reach anchor position, plus a slack loop, install limit stop on anchor end of load chain (see (2)) and attach end of chain to frame with special fillister head screw. Be certain chain is not twisted.

**NOTE:** The spring clip connecting link must be attached to anchor end of roller load chain before chain is run into hoist. Failure to do so may result in damage to chain or hoist.

(2) When installing limit stop on anchor end of load chain attach it at link. See Figure 3-1b.

**Two Piece Chain Stop (electronic limit switch)**

| Chain Size      | Number of Chain Links From End |
|-----------------|--------------------------------|
| 1/4" Wire Dia.  | 12 Links (9½")                 |
| 5/16" Wire Dia. | 10 Links (9")                  |

**Paddle Limit Switch**

|                 |         |
|-----------------|---------|
| 1/4" Wire Dia.  | 8 Links |
| 5/16" Wire Dia. | 8 Links |

e. **Wiring Hook-Up.** Before installing hoist, connect wiring to electrical controls in accordance with applicable wiring diagram. Wires are coded and/or numbered to agree with wiring diagrams.

f. **Proximity Switch Replacement/Adjustment.** The proximity switches are adjusted at the factory to have a gap of 1-2mm between the end of the sensor and the face of the sprocket gear. If the sprocket and/or sprocket gear are not being replaced, there should be no need to adjust the proximity switches. If the sprocket gear or sprocket have been replaced, or a proximity switch needs replacing, use the following procedure:

(1) The proximity switch needs to be set with an air gap of 1-2mm between the sensor end and the face of the sprocket gear. With the proximity switch removed, use a flashlight to look through the mounting hole to verify that a gear surface is directly below the mounting hole.

**CAUTION**

Failure to line the proximity switch up with a gear surface could result in the proximity switch being inserted too far. This will result in damage to the proximity switch and possibly gear case cover if the hoist is operated.

(2) Thread the proximity switch in until it bottoms out on the gear face. Do not over tighten. Back out one full turn. This will leave a gap of approximately 1mm.

(3) Tighten lock nut to secure proximity switch.

Proximity switches are equipped with a red LED that lights when it is sensing the presence of metal. An optional method for setting the proximity switch air gap would be to use a proximity sensor tester suitable for use with a 15v proximity switch. This is connected directly to the proximity switch, and lights the LED when a surface is sensed.

**WARNING**

**If the hoist loses power during operation or if chain is moved causing rotation of the sprocket without the electronic limit switch powered the limits may have shifted. Check upper and lower limit settings before resuming normal operation.**

The hoist electronic limit switch requires power while the chain is in motion to maintain the limits at the desired position. If the gearing rotates while power is removed from the unit, the limits will have to be reset. A common example of a situation causing such gear movement would be during replacement of the motor or brake.

If the hoist loses power during operation, the upper and lower limits will have shifted and need to be reset. The distance between limits will remain the same, but the entire range will have shifted up or down accordingly. Operation of the electronic limit switch is to be checked daily per ASTM/ANSI.B30.16.

**g. Lubricate Hoist. Lubricate hoist as outlined in Section IV.**

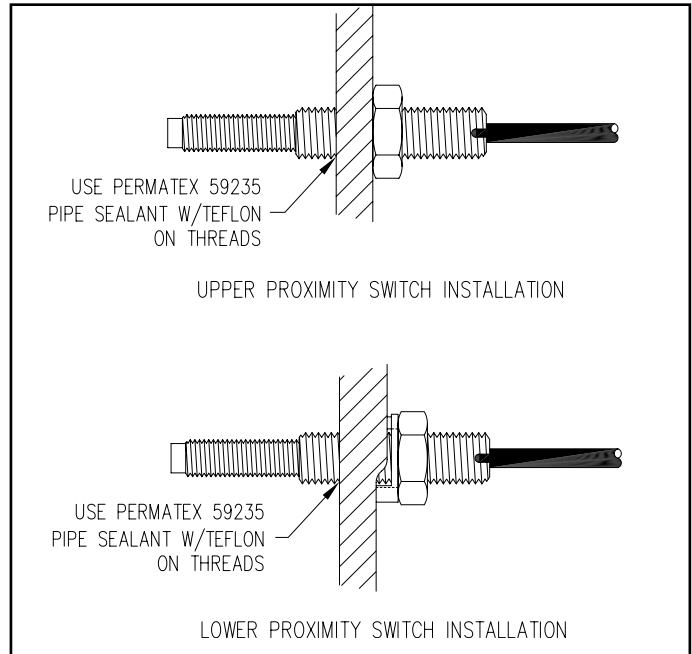

Figure 7-32.

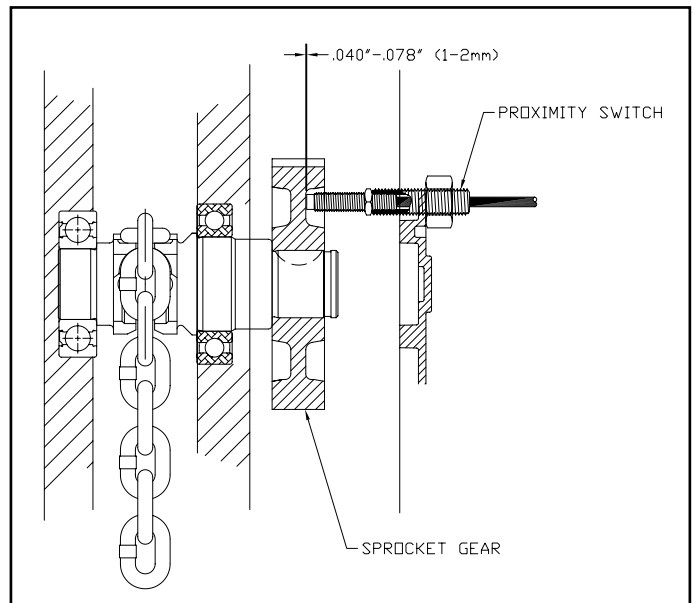

Figure 7-33.

7-12. TESTING HOIST.

a. **General.** After completion of reassembly and before placing hoist in service, hoist should be tested to insure safe operation. To test: suspend hoist from an overhead supporting member of sufficient strength to carry twice rated load; connect to a power supply of the specified voltage (see data plate attached to motor); and perform the following checks and adjustments.

b. **Check For Correct Control Operation.** Refer to Section II, paragraph 2-4. d, under "Warning."

c. **Check Upper and Lower Limit Stop Operation (paddle limit).** To determine if upper and lower limit stop functions properly, make the following checks while operating hoist with push button control and actuating the limit lever by hand:

(1) Depress "↑" push button and with chain running in raise direction, pull down on end of limit lever at tail chain side of hoist (left side facing cover end). The "UP" limit switch should cut off power, causing the hoist to stop.

(2) Depress "↓" push button and with chain running in lowering direction, push up on same end of limit lever. The "DOWN" limit switch should cut off power, causing the hoist to stop.

(3) If hoist does not stop in both travel directions, check for improper wiring. Refer to par. 6-2 and appropriate wiring diagram. If wiring is correct, check to see that limit switch is correctly installed.

(4) As a final check, operate hoist (no load) in the lowering direction and allow tail chain limit actuator to trip limit lever.

Hook should stop. Repeat check in hoisting direction and allow lower block to trip limit lever. Hook should stop.

d. **Check Upper and Lower Limit Stop Operation (electronic limit switch).** To determine if upper and lower limit stop functions properly, make the following checks while operating hoist with push button control and actuating the limit lever by hand:

(1) Press up push button and verify operation of electronic limit switch upper limit. Reset as necessary.

(2) Press down push button and verify operation of electronic limit switch lower limit. Reset as necessary.

(3) If hoist does not stop at one or both of the set limits, check for improper wiring. Refer to paragraph 6-2 and appropriate wiring diagram. If wiring is correct, check to see that proximity switches are correctly installed and sensing properly, paragraph 7-11.f.

e. **Check Hoist With Rated Load.** Attach rated load to lower hook and check hoist operation. If hoist does not lift rated load, refer to par. 7-13.

(1) Operate hoist to raise load. When control is released, hoist should instantaneously stop and hold load at that level.

(2) Operate hoist to lower load a short distance, then release control. Hoist should stop instantaneously and hold load at that level.

(3) If hoist does not stop or hold load refer to Section VI.

7-13. TEST PROCEDURE FOR CHECKING OPERATION OF OVERLOAD CLUTCH.

a. **General.** The overload clutch must be tested using known weights. The following prerequisites (par. (1) through (4)) must be strictly observed in performing this test.

(1) A qualified person shall determine before testing, that all structures supporting the hoist are adequately strong to withstand the test load of 200 percent of rated hoist load, whether hoist is tested in installed position or moved to a designated test facility.

(2) Loads used for testing must be accurately known.

(3) Test shall be made only by a qualified operator thoroughly familiar with the hoist and the purpose of the test.

(4) Provide adequate and proper rigging to insure test loads are securely attached, properly balanced, and will lift level.

b. **Test Procedure.** With the above prerequisites satisfied and hoist properly connected to electrical power, proceed with the test as follows:

(1) Using a known load equal to rated load of hoist, operate hoist to lift load. Raise load high enough to be certain the entire load is freely suspended. **Clutch should not slip at rated load.** If hoist does not lift rated load, clutch requires adjustment. Refer to Section V, par. 5-4. c.

(2) Increase load to 200 percent rated load and operate hoist to lift the load. **Clutch must slip,** causing the hoist to refuse to lift the load. If hoist lifts this overload, the overload clutch is out-of-adjustment and must be readjusted. Refer to Section V, par. 5-4. c.

(3) If clutch slips as required in step (2) above, continue to run hoist (clutch slipping-hoist refusing to lift load) for five (5) cycles of one (1) second each.

(4) Remove excess weight to return the load to rated hoist load. Lift rated load one final time to be certain that the clutch does not slip and that the hoist lifts the rated load.

|  |
|--|
|  <b>WARNING</b>   |
| <b>DO NOT LIFT MORE THAN RATED LOAD EXCEPT FOR TEST PURPOSES</b>   |
| <b>NOTICE</b><br><b>THIS EQUIPMENT MUST BE EFFECTIVELY GROUNDED ACCORDING TO THE NATIONAL ELECTRIC CODE, ARTICLE 250, 610-61 AND OTHER APPLICABLE CODES.</b> |

**SECTION IX - REPLACEMENT PARTS**

This section contains complete replacement parts information for your new **Budgit** Electric Hoist. The parts are grouped and illustrated in exploded view photos to permit easy identification. Each part in an illustration is keyed by reference number to a corresponding parts table. In the table will be found the BH part number, description and quantity required.

authorized testing equipment; and stock a complete inventory of genuine replacement parts.

**NOTICE:** Information herein is subject to change without notice. Parts must be ordered from an Authorized **Budgit** Repair Station or from a **Budgit** Hoist Distributor.

When ordering replacement parts it will be necessary that you include, with your order, the BH part number of parts required, plus, hoist catalog number and model number, which will be found on the hoist nameplate attached to hoist. For motors, complete motor nameplate data is required. Complete inspection, maintenance and overhaul service is available for **Budgit** Electric Hoists at any of the Authorized Repair Stations. All are staffed by qualified factory-trained servicemen; have

**The numbers assigned to the parts of our various assemblies in our parts lists are not the part numbers used in manufacturing the part. They are identification numbers, that when given with the hoist serial number, permit us to identify, select or manufacture, and ship the correct part needed for any hoist.**

**INDEX OF EXPLODED VIEW PARTS ILLUSTRATIONS**

| Figure No. | Title  | Page  |
|------------|--|-------|
| 9-1        | Frame and External Parts .....   | 33-35 |
| 9-2        | Upper Suspension, Load Chain and Lower Block Parts (2 ton Hoists) .....                  | 36-37 |
| 9-3        | Upper Suspension, Load Chain and Lower Block Parts (3 ton Hoists) .....                  | 38-39 |
| 9-4        | 2 and 3 Ton Lower Block Assembly .....   | 40    |
| 9-5        | Gearing and Load Brake Parts (1/4 and 1/2 Ton Hoists) .....                              | 41-42 |
| 9-6        | Gearing and Load Brake Parts (1 through 3 Ton Hoists) .....                              | 43-44 |
| 9-7a       | Electrical Control Units (Three Phase Single Speed Hoists, Paddle Limit) .....           | 45-46 |
| 9-7b       | Electrical Control Units (Three Phase Single Speed Hoists, Electronic Limit Switch)..... | 47-48 |
| 9-8a       | Electrical Control Units (Two Speed Hoists Only, Paddle Limit) .....                     | 49-50 |
| 9-8b       | Electrical Control Units (Two Speed Hoists Only, Electronic Limit Switch) .....          | 51-52 |
| 9-9a       | Electrical Control Units (Single Phase Hoists, Paddle Limit) .....                       | 53-54 |
| 9-9b       | Electrical Control Units (Single Phase Hoists, Electronic Limit Switch).....             | 55-56 |
| 9-10       | Limit Lever and Switch Parts.....  | 57    |
| 9-11       | Push Button Station and Conductor Cable Assembly (Single Speed Hoists) .....             | 58    |
| 9-12       | Push Button Station and Conductor Cable Assembly (Two Speed Hoists Only) .....           | 59    |
| 9-13       | Single Phase Motor Assembly .....  | 60    |
| 9-14       | Three Phase Motor Assembly .....   | 61-62 |
| 9-15       | Hoist Motor Brake .....  | 63    |

**ELECTRICAL CONTROL UNITS (Three phase Single Speed Hoists, Electronic Limit Switch)**



To enable us to expedite your parts order, always give Model and Catalog Number and Electric Current of Hoist. (See nameplate.)

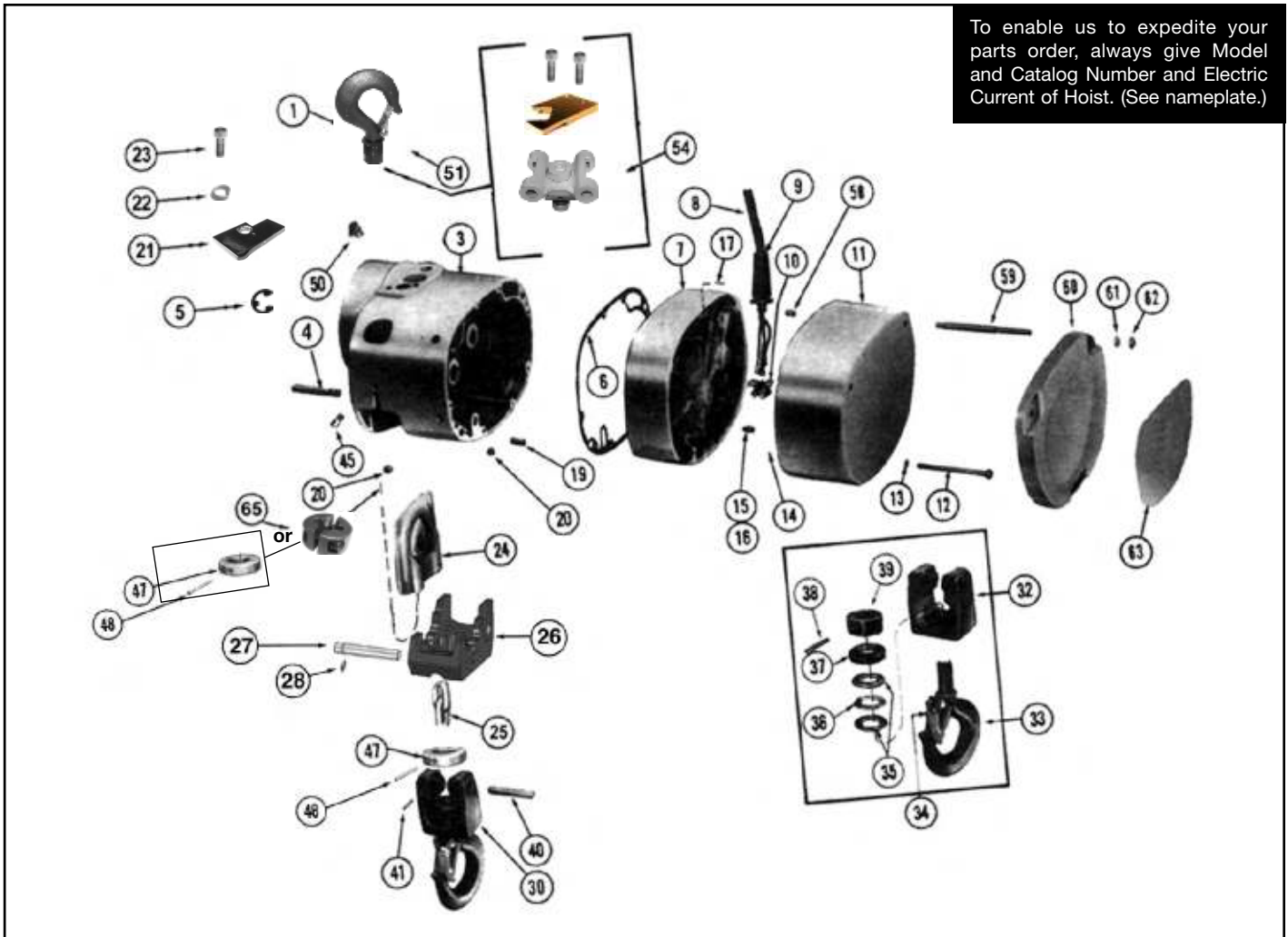

**Figure 9-1. FRAME AND EXTERNAL PARTS**  
**Standard and Plating Service Hoists**  
 (Except 2 through 3 Ton Model Upper Suspension, Load Chain and Lower Block)

| Ref. No. | Part Number | Description  | Qty. Req'd       |
|----------|-------------|--|------------------|
| 1        | BH4007A     | Hook Assembly-Upper with Latch (Includes Item 51) (Thru 1 ton)   | 1*               |
|          | BH-5027     | Hook Assembly-Upper with Latch (Includes Item 51) (Thru 1 ton) Plated  | 1*               |
| 2        | ---         | <i>This reference number is not used in the figure</i>   |                  |
| 3        | ***         | Frame Assembly   | 1                |
| 4        | BH-5009     | Pin-Support, chain guide   | 2                |
| 5        | BH-4008     | Retaining Clip, Chain Guide Pin  | 2                |
| 6        | BH-1007     | Gasket-Gearcase  | 1                |
| 7        | ***         | Cover Assembly-Gearcase  |                  |
| 8        | BH-1010     | Cable Assembly-Flexible, 5' (Incl. Items 9 & 10)<br>115 volt, 1 phase, 60 hertz hoists<br>230 volt, 1 phase, 60 hertz hoists<br>200/230/460/575 volt, 3 phase, 60 hertz hoists | 1<br>1<br>1<br>1 |
| 9        | BH-1096     | Grommet-Flexible Cable-3 phase<br>Grommet-Flexible Cable-1 phase   | 1<br>1           |
| 10       | BH-1014     | Clamp-Flexible Cable   | 1                |
| 11       | BH-1168     | Cover-Electrical Compartment<br>Without internal counterweight   | 1<br>1           |
|          | BH-1169     | With internal counterweight<br>Capacity Label (Not Shown)  | 1                |

(Continued on following page)

Figure 9-1. FRAME AND EXTERNAL PARTS - Continued

| Ref. No. | Part Number | Description  | Qty. Req'd |
|----------|-------------|--|------------|
| 11a      | BH-1190     | 1/4 Ton  |            |
|          | BH-1191     | 1/2 Ton  |            |
|          | BH-1192     | 1 Ton  |            |
|          | BH-1193     | 2 Ton  |            |
|          | BH-1194     | 3 Ton  |            |
| 12       | BH-1020     | Screw-Fillister Head Machine   | 3          |
| 13       | BH-1021     | Hi-Collar Helical Spring Lock Washer (1/4)                                       | 3          |
| 14       | BH-1022     | Ring-Retaining   | 8          |
| 15       | BH-1023     | Regular Helical Spring Lock Washer (#10 Pltd.)                                   | 8          |
| 16       | BH-1024     | Hex Socket Head Cap Screw (#10-24 x 3/4)   | 2          |
| 17       | BH-1025     | Grooved Pin (Type D 1/8 x 1/2 Pltd.)   | 1          |
| 18       | BH-1026     | Grommet-(Motor Driven Trolley Models)-Not Shown                                  | 2          |
| 19       | BH-1027     | Dowel Pin (3/8 x 3/4)  | 2          |
| 20       | BH-1028     | Hex Socket Pipe Plug (1/8)   | 1          |
| 21       | BH-5023     | Suspension Bushing Keeper  | 1          |
| 22       | BH-4016     | Lock Washer  | 1          |
| 23       | BH-4017     | Hex Socket Cap Screw   |            |
| 24       |             | Guide Assembly-Coil Load Chain   | 1          |
|          | BH-1031     | 1/4 & 1/2 ton Hoists   |            |
|          | BH-1032     | 1 through 3 ton Hoists   |            |
| 25       | ***         | Chain Assembly-Coil, load  | 1*         |
|          | BH-1033     | 1/4" Dia.-1/4 & 1/2 ton Hoists   |            |
|          | BH-1034     | 5/16" Dia.-1 ton Hoists  |            |
|          | BH-1080     | 1/4" Dia.-1/4 & 1/2 ton Hoists - Zinc Plated                                     |            |
|          | BH-1086     | 5/16" Dia.-1 ton Hoists - Zinc Plated  |            |
| 26       | BH-5020     | Stop Shoe (Electronic Limit Equipped Only)                                       | 1          |
| 27       | BH-5021     | Support Pin  | 1          |
| 28       | BH-5022     | Retaining Ring   | 1          |
| 29       | —           | <i>This reference number is not used in the figure</i>                           |            |
| 30       |             | Block Assembly-Lower, (Incl. items 32 through 39)                                | 1*         |
|          | BH-5028     | For 1/4 ton Hoists   |            |
|          | BH-1035     | For 1/4 ton Hoists Plated  |            |
|          | BH-1035A    | For 1/2 ton Hoists   |            |
|          | BH-5029     | For 1/2 ton Hoists Plated  |            |
|          | BH-5046     | For 1 ton Hoists   |            |
|          | BH-5030     | For 1 ton Hoists Plated  |            |
|          |             | Note: Lower block assemblies do not include attaching pins.<br>Order separately. |            |
| 31       | —           | <i>This reference number is not used in the figure</i>                           |            |
| 32       |             | Body-Lower Block   | 1*         |
|          | BH-1174     | 1/4 ton Hoists   |            |
|          | BH-5031     | 1/4 ton Hoists Plated  |            |
|          | BH-1174A    | 1/2 ton Hoists   |            |
|          | BH-5032     | 1/2 ton Hoists Plated  |            |
|          | BH-1175     | 1 ton Hoists   |            |
|          | BH-5033     | 1 ton Hoists Plated  |            |
| 33       |             | Hook, Nut and Latch Assembly-Lower Block   | 1          |
|          | BH-5047     | 1/4 thru 1 ton Hoists  |            |
|          | BH-5034     | 1/4 thru 1 ton Hoists Plated   |            |
| 34       |             | Latch Kit-Hook, lower  | 1          |
|          | BH-5035     | 1/4 thru 1 ton Hoists  |            |
| 35       | BH-1178     | Washer-Thrust, needle bearing  | 2          |
| 36       | BH-1179     | Bearing Assembly-Needle, thrust  | 1          |
| 37       | BH-1180     | Shield-Bearing   | 1          |
| 38       | BH-1181     | Grooved Pin (Type F 5/32 x 1-1/8 Pltd.)  | 1          |
| 39       | **          | Nut-Hook   | 1          |
| 40       |             | Pin-Connecting, lower block  | 1          |
|          | BH-1037     | 1/4 and 1/2 ton Hoists   |            |
|          | BH-1038     | 1 ton Hoists   |            |

(Continued on following page)

Figure 9-1. FRAME AND EXTERNAL PARTS - Continued

| Ref. No. | Part Number | Description  | Qty. Req'd |
|----------|-------------|--|------------|
| 41       | BH-1045     | Slotted Spring Pin (3/32 x 3/4 Pltd.)  | 1          |
| 42-44    | —           | <i>These reference numbers are not used in the figure</i>                      |            |
| 45       | BH-5048     | Hex Flange Screw, Self-Locking   | 1          |
| 46       | —           | <i>This reference number is not used in the figure</i>                         |            |
| 47       |             | Limit Stop (Paddle Limit Switch)   | 2          |
|          | BH-1098     | 1/4" Coil Chain  |            |
|          | BH-1099     | 5/16" Coil Chain   |            |
| 48       | BH-1184     | Grooved Pin (Limit Stop BH-1098) (Type F 7/32 x 2 Pltd.)                       | 2          |
|          | BH-1185     | Grooved Pin (Limit Stop BH-1099) (Type F 1/4 x 2 Pltd.)                        | 2          |
| 49       | —           | <i>This reference number is not used in the figure</i>                         |            |
| 50       | BH-4010     | Filler Assembly-Oil  | 1          |
| 51       | BH-1183     | Latch Kit-Hook (upper) 1/4 through 1 ton                                       | 1          |
| 52-53    | —           | <i>These reference numbers are not used in the figure</i>                      |            |
| 54       | BH-5025     | Lug Suspension Assembly  | 1*         |
|          |             | The following items are for two speed hoists with 2-1/4 horsepower motor only: |            |
| 55-57    | —           | <i>These reference numbers are not used in the figure</i>                      |            |
| 58       | BH-1158     | Insert-Coil  | 3          |
| 59       |             | Support Stud   |            |
|          | BH-1159     | Top  | 2          |
|          | BH-1160     | Bottom   | 1          |
| 60       | BH-1161     | Counterweight  | 1          |
| 61       | BH-1162     | Plain Washer (Type W 1/4 Pltd.)  | 3          |
| 62       | BH-1163     | Heavy Hex Self-Locking Nut (1/4 - 20)  | 3          |
| 63       |             | Capacity Label   | 1          |
|          | BH-1164     | 1 Ton  |            |
|          | BH-1165     | 2 Ton  |            |
|          | BH-1166     | 3 Ton  |            |
| 65       |             | Chain Stop Assembly (Electronic Limit Switch)                                  |            |
|          | BH-5010     | For 5/16" Coil Chain   | 1          |
|          | BH-5011     | For 1/4" Coil Chain  | 1          |

\* Refer to Figure 9-2 for 2 Ton Model Upper Suspension, Load Chain and Lower Block Parts.  
Refer to Figure 9-3 for 3 Ton Model Upper Suspension, Load Chain and Lower Block Parts.

\*\* Hook and suspension bolt nuts are not serviced separately. They are available only with hook or bolt as assemblies.

\*\*\* For frame assembly or gearcase cover assembly, please consult factory. Be sure to have serial number available.

## REPLACEMENT CHAIN

| <u>TYPE CHAIN</u>            | <u>BULK</u> |
|------------------------------|-------------|
| Coil (1/4" Dia.)             | BH-1066     |
| Coil (5/16" Dia.)            | BH-1069     |
| Coil (1/4" Dia. Zinc Plate)  | BH-1083     |
| Coil (5/16" Dia. Zinc Plate) | BH-1093     |

To enable us to expedite your parts order, always give Model and Catalog Number and Electric Current of Hoist. (See nameplate.)

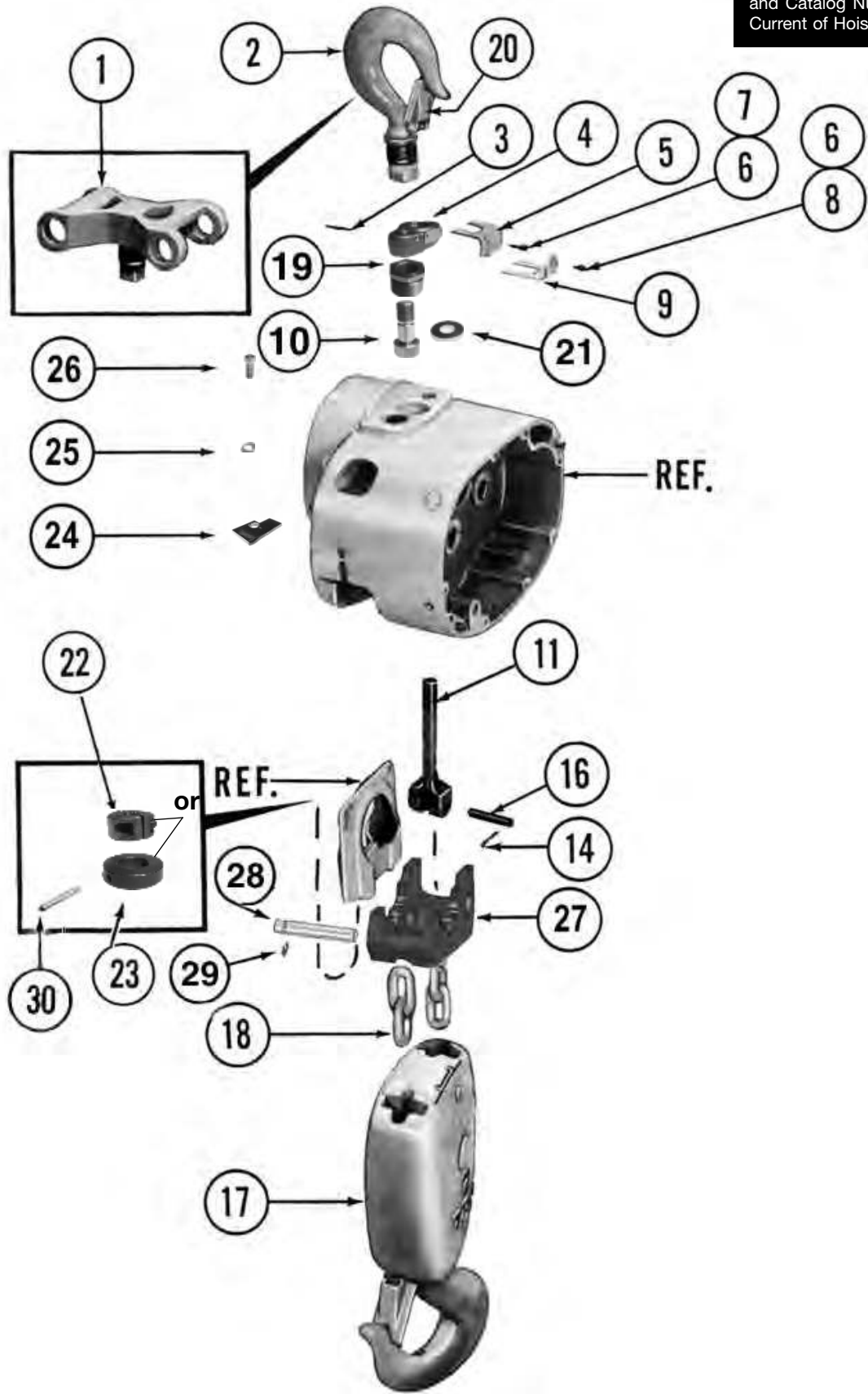

Figure 9-2. UPPER SUSPENSION, LOAD CHAIN AND LOWER BLOCK PARTS  
(2 Ton Hoists)

10251B

Figure 9-2. UPPER SUSPENSION, LOAD CHAIN AND LOWER BLOCK PARTS - Continued

| Ref. No. | Part Number    | Description   | Qty. Req'd |
|----------|----------------|---|------------|
| 1        | 905422         | Bracket Assembly Kit- Lug Suspension<br>(Coil Chain Model Only. Includes Items 6, 8 and 9). | 1          |
| 2        | BH-1102        | Hook Assembly-Upper (Includes Items 5, 6, 7 and 20).  | 1          |
|          | BH-5036        | Hook Assembly-Upper (Includes Items 5, 6, 7 and 20) Plated                                  |            |
| 3        | BH-1030        | Grooved Pin (Type F 3/16 x 1-1/4 Pltd.)   | 2          |
| 4        |                | Block Assembly-Upper  | 1          |
|          | BH-4013        | Coil Chain Models, Includes Items 3, 10, 11, 14, 16, 19 and 21                              |            |
| 5        | BH-1106        | Lock Assembly-Suspension Bushing  | 1          |
| 6        | BH-1107        | Regular Helical Spring Lock Washer (#10 Pltd.)  | 3          |
| 7        | BH-1108        | Hex, Socket Head Cap Screw (#10-24 x 1/2)   | 2          |
| 8        | BH-1109        | Hex, Socket Head Cap Screw (#10-24 x 3/8)   | 1          |
| 9        | BH-1061        | Plate - Lock (Coil Chain Lug Suspension Models Only)  | 1          |
| 10       | *              | Lug Suspension Stud   | 1          |
| 11       | *              | Anchor - Coil Load Chain  | 1          |
| 14       | BH-1111        | Cotter Pin (3/32 x 3/4)   | 1          |
| 16       | BH-1113        | Pin-Coil Chain Anchor   | 1          |
| 17       | (See Fig. 9-4) | Block Assembly-Lower  | 1          |
| 18**     | BH-1114        | Chain Assembly  | 1          |
|          | BH-1115        | Chain Assembly (Zinc Plated)  | 1          |
| 19       | *              | Suspension Bushing  | 1          |
| 20       | BH-2213        | Latch Kit-Hook  | 1          |
| 21       | BH-4012        | Spacer Washer   | 1          |
| 22       | BH-5010        | Chain Stop (Electronic Limit Switch)  | 1          |
| 23       | BH-1099        | Actuator (Paddle Limit Switch)  | 1          |
| 24       | BH-5023        | Suspension Bushing Keeper   | 1          |
| 25       | BH-4016        | Lock Washer   | 1          |
| 26       | BH-4017        | Hex Socket Head Cap Screw   | 1          |
| 27       | BH-5020        | Stop Shoe (Electronic Limit Equipped)   | 1          |
| 28       | BH-5021        | Support Pin   | 1          |
| 29       | BH-5022        | Snap Ring   | 1          |
| 30       | BH-1185        | Grooved Pin (Type F 1/4 x 2 Pltd.)  | 1          |

\* Not available as individual parts. Order upper block assembly, Item 4.

\*\* Load Chain Assemblies listed are for hoists with standard 10 ft. lists. Bulk chain is available in 1 ft. increments and 50 ft. lengths as follows:

| Type Chain                   | 50' Lengths   | Bulk    |
|------------------------------|---------------|---------|
| Link (5/16" Dia.)            | Not Available | BH-1069 |
| Link (5/16" Dia. Zinc Plate) | Not Available | BH-1093 |

To enable us to expedite your parts order, always give Model and Catalog Number and Electric Current of Hoist. (See nameplate.)

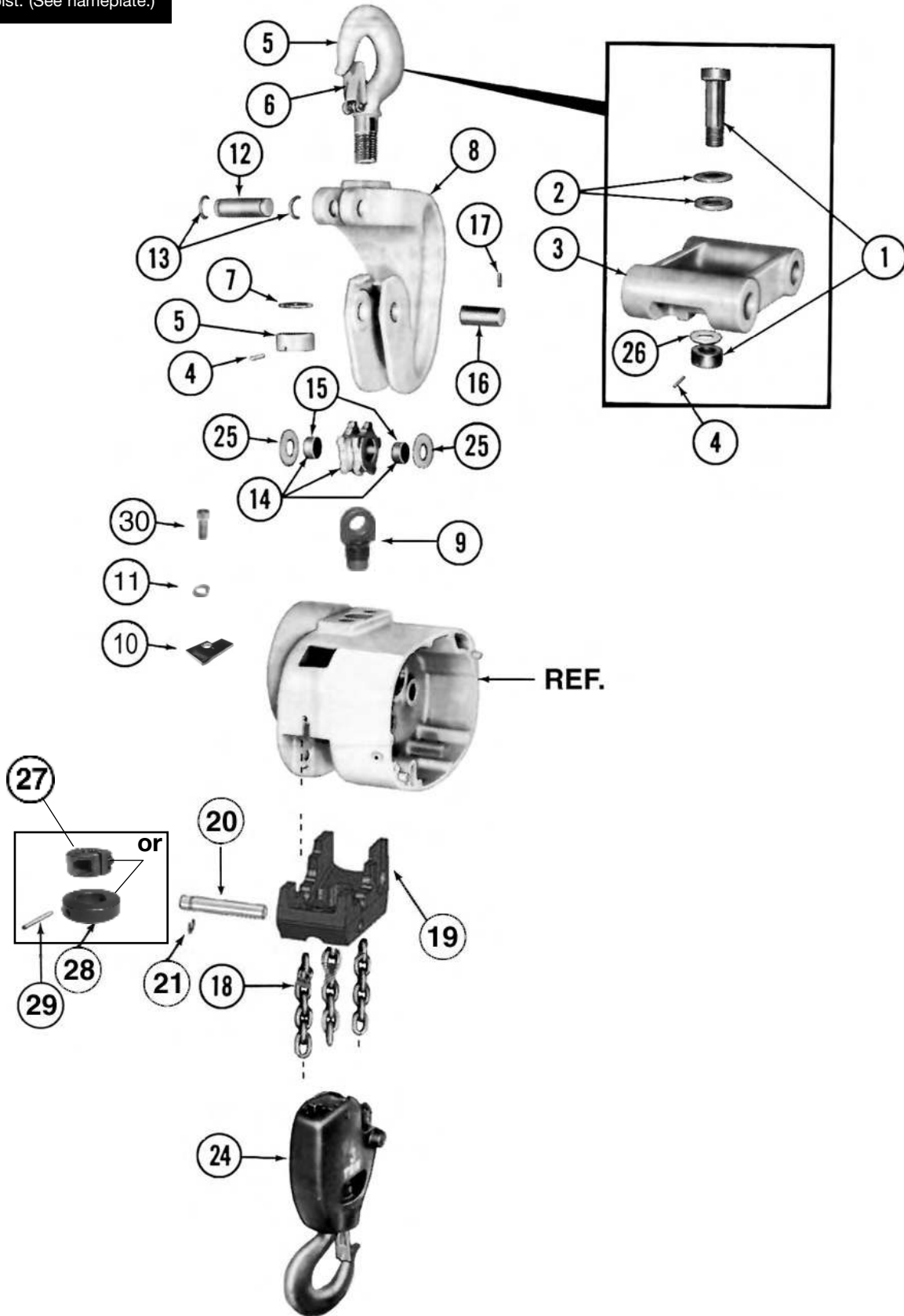

Figure 9-3. UPPER SUSPENSION, LOAD CHAIN AND LOWER BLOCK PARTS (3 Ton Hoists)

**Figure 9-3. UPPER SUSPENSION, LOAD CHAIN AND LOWER BLOCK PARTS - Continued**

| Ref. No. | Part Number  | Description   | Qty. Req'd |
|----------|--------------|---|------------|
| 1        | BH-1131      | Suspension Pin and Nut Assembly                       | 1          |
| 2        | BH-1132      | Spherical Washer                                      | 1 Pr.      |
| 3        | 905424       | Suspension Lug Kit<br>(Includes Items 1, 2, 4 and 26) | 1          |
| 4        | BH-1134      | Pin - Grooved (Type A 3/16 x 2 Pltd.)                 | 1          |
| 5        | BH-1135      | Hook/Latch and Nut (Includes Item 6)                  | 1          |
|          | BH-5037      | Hook/Latch and Nut (Includes Item 6) Plated           | 1          |
| 6        | BH-2214      | Latch Kit, Hook                                       | 1          |
| 7        | BH-2217      | Washer, Thrust  | 1          |
| 8        | BH-1138      | Hanger  | 1          |
| 9        | BH-4018      | Connecting Rod Assembly                               | 1          |
| 10       | BH-5023      | Suspension Bushing Keeper                             | 1          |
| 11       | BH-4016      | Lock Washer   | 1          |
| 12       | BH-1142      | Pin, Connection                                       | 1          |
| 13       | BH-1143      | Ring, Retaining                                       | 2          |
| 14       | BH-1144      | Sprocket & Bushing Assembly (Includes Item 15)        | 1          |
| 15       | BH-1145      | Bushing   | 2          |
| 16       | BH-5019      | Pin, Sprocket   | 1          |
| 17       | BH-1147      | Grooved Pin (Type A 3/16 x 3/8 Pltd.)                 | 1          |
| 18       | BH-1148      | Chain Assembly, Coil Load                             | 1          |
|          | BH-5045      | Chain Assembly, Coil Load Plated                      | 1          |
| 19       | BH-5020      | Stop Shoe (Electronic Limit Equipped)                 | 1          |
| 20       | BH-5021      | Support Pin   | 1          |
| 21       | BH-5022      | Snap Ring   | 1          |
| 24       | See Fig. 9-4 | Block Assembly, Lower, Coil Chain                     |            |
| 25       | BH-2210      | Washer, Thrust  | 2          |
| 26       | BH-1154      | Washer  | 1          |
| 27       | BH-5010      | Chain Stop Assembly (Electronic Limit Equipped)       | 1          |
| 28       | BH-1099      | Actuator (Paddle Limit Equipped)                      |            |
| 29       | BH-1185      | Grooved Pin (Type F 1/4 x 2 Pltd.)                    |            |
| 30       | BH-4017      | Hex Socket Head Cap Screw                             | 2          |

**NOTICE**

Always insist on factory approved **Budgit** Hoist replacement parts when servicing this equipment. Parts are available from your local Authorized Repair Station.

**NOTES**

---



---



---



---



---



---



---



---

To enable us to expedite your parts order, always give Model and Catalog Number and Electric Current of Hoist. (See nameplate.)

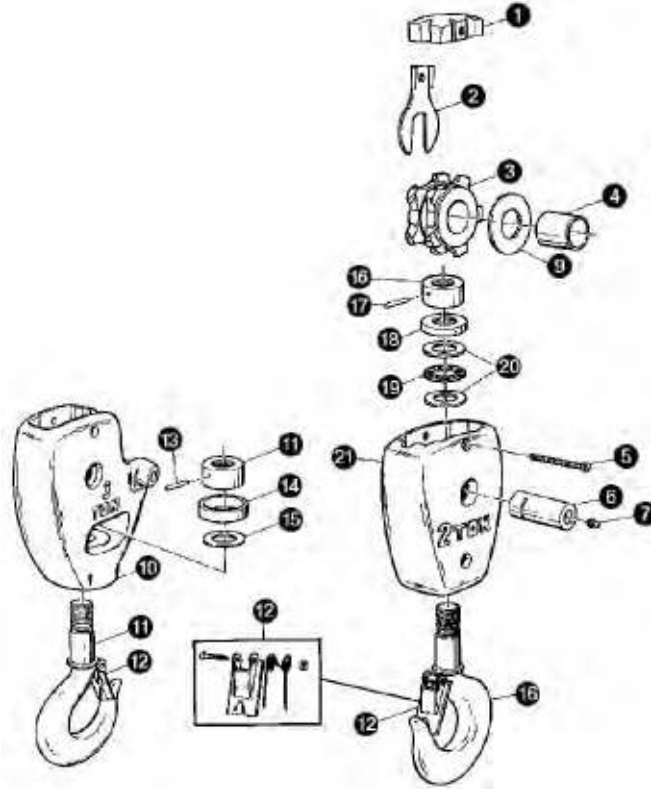

12444A

Figure 9-4. 2 and 3 TON LOWER BLOCK ASSEMBLIES

| Ref. No. | Part Number  | Description  | Quantity Required |       |
|----------|--|--|-------------------|-------|
|          |  |  | 2 Ton             | 3 Ton |
| 1        | BH-2219  | Block Assembly-Lower Complete                            | 1                 | —     |
|          | BH-5038  | Block Assembly-Lower Complete Plated                     | 1                 | —     |
|          | BH-2218  | Block Assembly-Lower Complete                            | —                 | 1     |
|          | BH-5039  | Block Assembly-Lower Complete Plated                     | —                 | 1     |
|          | BH-2202  | Guide-Center   | 1                 | 1     |
|          | BH-5042  | Guide-Center Anodized                                    | 1                 | 1     |
|          | BH-2203  | Lock-Sprocket Pin  | 1                 | 1     |
|          | BH-2204  | Sprocket-Coil Chain                                      | 1                 | 1     |
|          | BH-2205  | Bushing-Sprocket   | 1                 | 1     |
|          | BH-2206  | Screw-Fillister Head, Self locking                       | 1                 | 1     |
|          | BH-2207  | Pin-Sprocket   | 1                 | 1     |
|          | BH-2208  | Fitting-Hydraulic Drive                                  | 1                 | 1     |
|          | BH-2210  | Washer, Thrust   | 1                 | 1     |
|          | BH-2211  | Body Assembly-Lower Block                                | —                 | 1     |
|          | BH-5040  | Body Assembly-Lower Block Anodized                       | —                 | 1     |
|          | BH-2212  | Hook/Latch and Nut (Includes Items 12, 13 and 15)        | —                 | 1     |
|          | BH-5044  | Hook/Latch and Nut (Includes Items 12, 13 and 15) Plated | —                 | 1     |
|          | BH-2213  | Latch Kit, Hook  | 1                 | —     |
|          | BH-2214  | Latch Kit, Hook  | —                 | 1     |
|          | BH-2215  | Pin, Grooved   | —                 | 1     |
|          | BH-2216  | Shroud   | —                 | 1     |
| BH-2217  | Washer, Thrust                                       | —  | 1                 |       |
| BH-2220  | Hook/Latch and Nut (Includes Items 12 and 17)        | 1  | —                 |       |
| BH-5043  | Hook/Latch and Nut (Includes Items 12 and 17) Plated | 1  | —                 |       |
| BH-2221  | Pin, Grooved   | 1  | —                 |       |
| BH-2222  | Shield, Bearing                                      | 1  | —                 |       |
| BH-2223  | Bearing Assembly-Needle, Thrust                      | 1  | —                 |       |
| BH-2224  | Washer, Thrust                                       | 2  | —                 |       |
| BH-2225  | Body-Lower Block                                     | 1  | —                 |       |
| BH-5041  | Body-Lower Block Anodized                            | 1  | —                 |       |



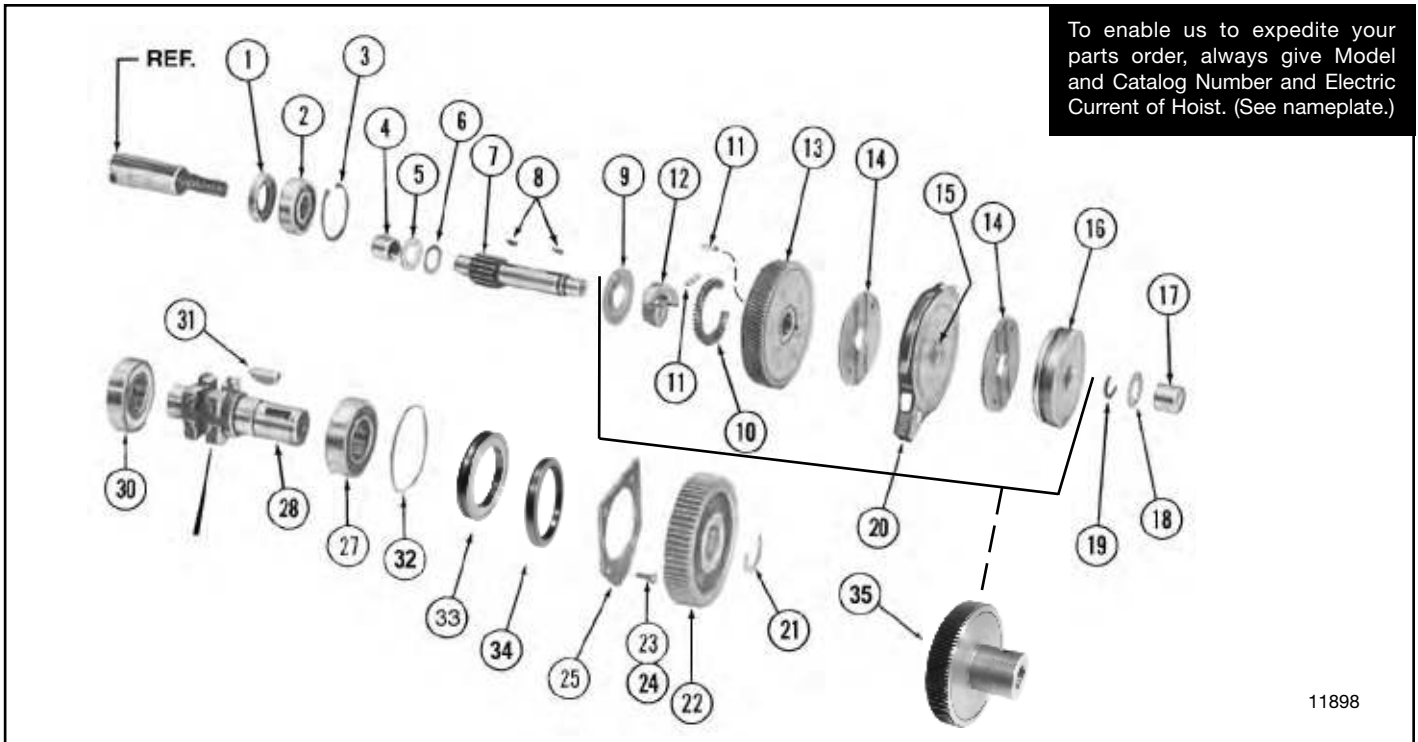

Figure 9-5. GEARING AND LOAD BRAKE PARTS (1/4 and 1/2 Ton Hoists)

| Ref. No. | Part Number | Description   | Qty. Req'd |
|----------|-------------|---|------------|
| 1        | BH-1201     | Seal-Oil, motor shaft   | 1          |
| 2        | BH-1202     | Bearing Assembly-Ball, motor shaft  | 1          |
| 3        | BH-1203     | Ring-Retaining, Internal  | 1          |
| 4        | BH-1237     | Bearing Assembly-Needle, 11/16" I.D. (36 rollers, grease retained)                      | 1          |
| 5        | BH-1205     | Bearing-Thrust, bronze  | 1          |
| 6        | BH-1206     | Washer-Thrust, 11/16" I. D. (Used with 14 tooth Pinion Load Brake Shaft-13H-1207 below) | 1          |
| 7        |             | Shaft & Integral Pinion-load brake,   |            |
|          | BH-1207     | 14 teeth  | 1          |
|          | BH-1208     | 23 teeth  |            |
|          | BH-1209     | 36 teeth  |            |
| 8        | BH-1210     | Key-Woodruff  | 2          |
| 9        | BH-1239     | Retainer-Spring, load brake   | 1          |
| 10       | BH-1212     | Spring-load brake (Plain-no color code)   | 1          |
|          | BH-1213     | Spring-load brake (Yellow color code)   | 1          |
| 11       | BH-1214     | Pin-Grooved   | 2          |
| 12       | BH-1216     | Cam-load brake  | 1          |
| 13       |             | Gear & Clutch Assembly-load brake   | 1          |
|          | BH-1240     | For use with 1/4 H.P. Motor   |            |
|          | BH-1241     | For use with 1 /2 H.P. Motor  |            |
|          | BH-1242     | For use with 1 H.P. Motor   |            |
| 14       | BH-1218     | Disc-Friction, load brake   | 2          |
| 15       | BH-1238     | Bushing—Ratchet   | 2          |
| 16       | BH-1219     | Flange—load brake   | 1          |
| 17       | BH-1220     | Bearing Assembly-Needle, 5/8" I.D.  | 1          |
| 18       | BH-1221     | Washer-Thrust, 5/8" I.D.  | 1          |
| 19       | BH-1222     | Ring-Snap, brake flange   | 1          |
| 20       | BH-1223     | Pawl & Ratchet Assembly-load brake (includes item 15)                                   | 1          |
| 21       | BH-1224     | Ring-Snap, sprocket gear  | 1          |
| 22       |             | Gear-Sprocket   |            |
|          | BH-1225     | 74 teeth  | 1          |
|          | BH-1226     | 65 teeth  |            |
|          | BH-1227     | 52 teeth  |            |

(Continued on following page)

Figure 9-5. GEARING AND LOAD BRAKE PARTS - Continued

| Ref. No. | Part Number | Description                          | Qty. Req'd |
|----------|-------------|--------------------------------------|------------|
| 23       | BH-1059     | Screw Hex Socket Head Cap            | 4          |
| 24       | BH-1229     | Lockwasher- Spring Type              | 4          |
| 25       | BH-1230     | Plate - Retainer, Sprocket Bearing   | 1          |
| 27       | BH-1232     | Bearing Assembly- Ball, Sprocket     | 1          |
|          | BH-1318     | Ball Bearing On Later Model Hoists   | 1          |
| 28       | BH-1311     | Sprocket-Coil Chain (1/4" Dia. Wire) | 1          |
| 30       | BH-1235     | Bearing Assembly - Ball, Sprocket    | 1          |
| 31       | BH-1236     | Key - Woodruff                       | 1          |
| 32       | BH-1315     | O-Ring                               | 1          |
| 33       | BH-1316     | Seal Disk                            | 1          |
| 34       | BH-1317     | Seal - Oil                           | 1          |
| 35**     | BH-4019     | Clutch Assembly - 1/4 hp             | 1          |
|          | BH-4020     | 1/2 hp                               |            |
|          | BH-4021     | 1 hp                                 |            |

\*\* This gear and clutch assembly should not be field disassembled.  
 Replace assembly only as clutch pressure is preset at factory based on hoist capacity and motor H.P.  
 Replaces items 9-16 on non-load brake equipped models

**NOTES**

---

---

---

---

---

---

---

---

---

---

---

---

---

---

---

---

---

---

---

---

---

---

---

---

---

---

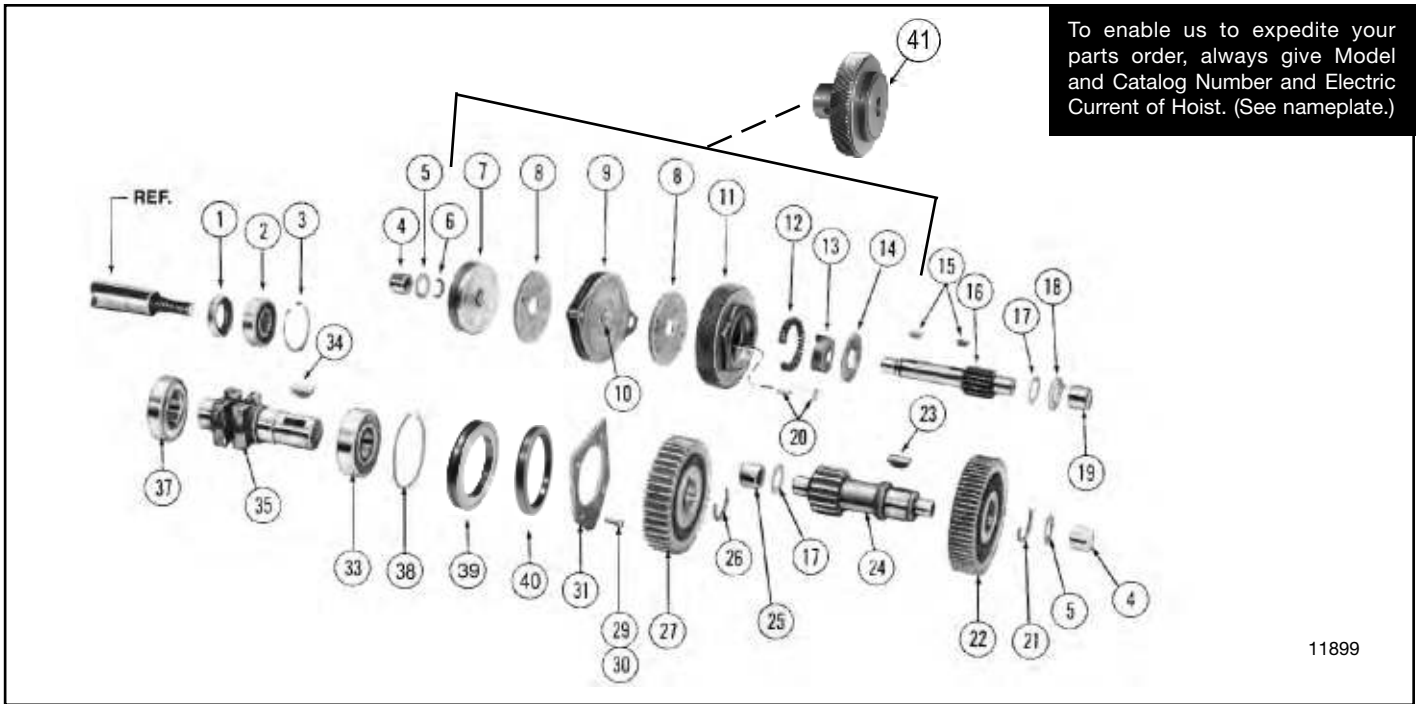

Figure 9-6. GEARING AND LOAD BRAKE PARTS (1 thru 3 Ton Hoists)

| Ref. No. | Part Number | Description   | Qty. Req'd |
|----------|-------------|---|------------|
| 1        | BH-1201     | Seal-Oil, motor shaft   | 1          |
| 2        | BH-1202     | Bearing Assembly-Ball, motor shaft                                  | 1          |
| 3        | BH-1203     | Ring-Retaining, Internal  | 1          |
| 4        | BH-1220     | Bearing Assembly-Needle, 5/8" I.D.                                  | 2          |
| 5        | BH-1221     | Washer-Thrust, 5/8" I.D.  | 2          |
| 6        | BH-1222     | Ring-Snap, brake flange   | 1          |
| 7        | BH-1219     | Flange-Load Brake   | 1          |
| 8        | BH-1218     | Disc-Friction, load brake   | 2          |
| 9        | BH-1223     | Pawl and Ratchet Assembly-Load Brake (includes item 15)             | 1          |
| 10       | BH-1238     | Bushing-Ratchet   | 1          |
| 11       | BH-1241     | Gear and Clutch Assembly-Load Brake<br>For use with 1 /2 H.P. Motor | 1          |
|          | BH-1242     | For use with 1 and 2-1/2 H.P. Motors                                |            |
| 12       | BH-1212     | Spring-Load Brake (Plain-no color code)                             | 1          |
| 13       | BH-1216     | Cam-Load Brake  | 1          |
| 14       | BH-1239     | Retainer-Spring, Load Brake   | 1          |
| 15       | BH-1210     | Key-Woodruff  | 2          |
| 16       | BH-1207     | Shaft and Integral Pinion-Load Brake<br>14 teeth                    | 1          |
|          | BH-1208     | 23 teeth  |            |
| 17***    | BH-1206     | Washer-Thrust, 11/16" I.D.  | 2          |
| 18       | BH-1205     | Bearing-Thrust, bronze  | 1          |
| 19       | BH-1204     | Bearing Assembly-Needle, 11 /16" I.D.                               | 1          |
| 20       | BH-1214     | Pin-Grooved   | 2          |
| 21       | BH-1224     | Ring-Snap, intermediate gear  | 1          |
| 22       | BH-1225     | Gear-Intermediate<br>74 teeth                                       | 1          |
|          | BH-1226     | 65 teeth  |            |
| 23       | BH-1236     | Key-Woodruff  | 1          |
| 24       | BH-1304     | Shaft and Integral Pinion-Intermediate                              | 1          |
| 25       | BH-1237     | Bearing Assembly-Needle, 11/16" I.D.                                | 1          |
| 26       | BH-1305     | Ring-Snap, sprocket gear  | 1          |
| 27       | BH-1306     | Gear-Sprocket   | 1          |
| 28       | —           | <i>This reference number is not used in the figure</i>              |            |
| 29       | BH-1228     | Screw-Fillister Head Machine  | 4          |

(Continued on following page)

Figure 9-6. GEARING AND LOAD BRAKE PARTS - Continued

| Ref. No. | Part Number | Description  | Qty. Req'd |
|----------|-------------|--|------------|
| 30       | BH-1229     | Lockwasher - Spring Type                               | 4          |
| 31       | BH-1230     | Plate - Retainer, Sprocket Bearing                     | 1          |
| 32       | —           | <i>This reference number is not used in the figure</i> |            |
| 33       | BH-1232     | Bearing Assembly - Ball, Sprocket                      | 1          |
|          | BH-1318     | Ball Bearing On Later Model Hoists                     | 1          |
| 34       | BH-1308     | Key -Woodruff, Sprocket                                | 1          |
| 35       |             | Sprocket - Coil Chain                                  |            |
|          | BH-1311     | 1/4" Dia. Wire   | 1          |
|          | BH-1312     | 5/16" Dia. Wire  | 1          |
| 36       | —           | <i>This reference number is not used in the figure</i> |            |
| 37       | BH-1235     | Bearing Assembly - Ball, Sprocket                      | 1          |
| 38       | BH-1315     | O-Ring   | 1          |
| 39       | BH-1316     | Seal Disk  | 1          |
| 40       | BH-1317     | Seal - Oil   | 1          |
| 41**     | BH-4020     | Clutch Assembly 1/2                                    |            |
|          | BH-4021     | Clutch Assembly 1 & 2-1/2                              |            |

\*\* This gear and clutch assembly should not be field disassembled.  
 Replace assembly only as clutch pressure is preset at factory based on hoist capacity and motor H.P.  
 Ref. No. 41 is replaced by Ref. Nos. 7 thru 14 on non-load brake equipped hoists.

\*\*\* Ref. No. 17 occurs next to Ref. No. 16 for 14 tooth pinion shaft only.

NOTES

---

---

---

---

---

---

---

---

---

---

---

---

---

---

---

---

---

---

---

---

---

---

---

---

---

---

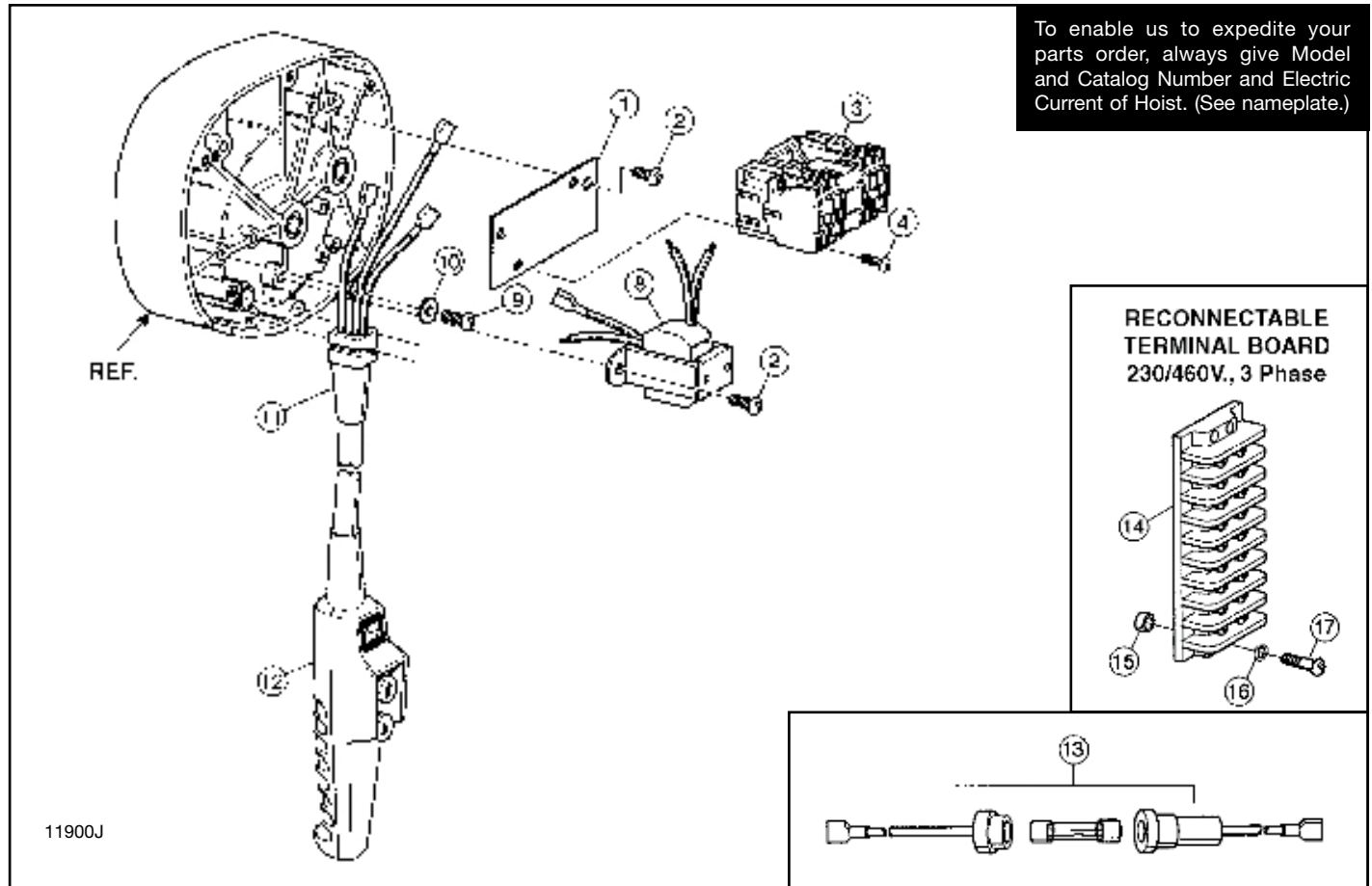

Figure 9-7a. ELECTRICAL CONTROL UNITS (Three phase Single Speed Hoists, Paddle Limit)

| Ref. No. | Part Number   | Description  | Qty. Req'd |
|----------|---------------|--|------------|
| 1        | BH-3800       | Contactor and Mounting Plate Assembly (Includes Ref. Nos. 1, 3 and 4)  | 1          |
|          | BH-3801       | Three Phase 24V Control  |            |
|          | BH-3802       | Three Phase 115V Control   |            |
| 2        | BH-3802       | Mounting Plate - Contactor   | 1          |
| 3        | BH-2155       | Sems Round Head Machine Screw with External Lock Washer (#10-24 x 3/8) | 5          |
|          |               | Contactor Assembly   | 1          |
|          | BH-3803       | Three Phase 24V Control  |            |
|          | BH-3804       | Three Phase 115V Control   |            |
| 4        | BH-2189       | Pan Head Self Tapping Screw (#8-32 x 1/2)                              | 2          |
| 5        | —             | <i>This reference number is not used in the figure</i>                 |            |
| 6        | —             | <i>This reference number is not used in the figure</i>                 |            |
| 7        | See Fig. 9-11 | Limit Switch and Shaft Assembly  | 1          |
| 8        |               | Transformer  | 1          |
|          | BH-2166       | Three Phase 208V/24V   |            |
|          | BH-3805       | Three Phase 230V/460V/24V  |            |
|          | BH-2168       | Three Phase 575V/24V   |            |
|          | BH-2169       | Three Phase 208V/115V  |            |
|          | BH-3806       | Three Phase 230V/460V/115V   |            |
|          | BH-2172       | Three Phase 575V/115V  |            |

(Continued on following page)



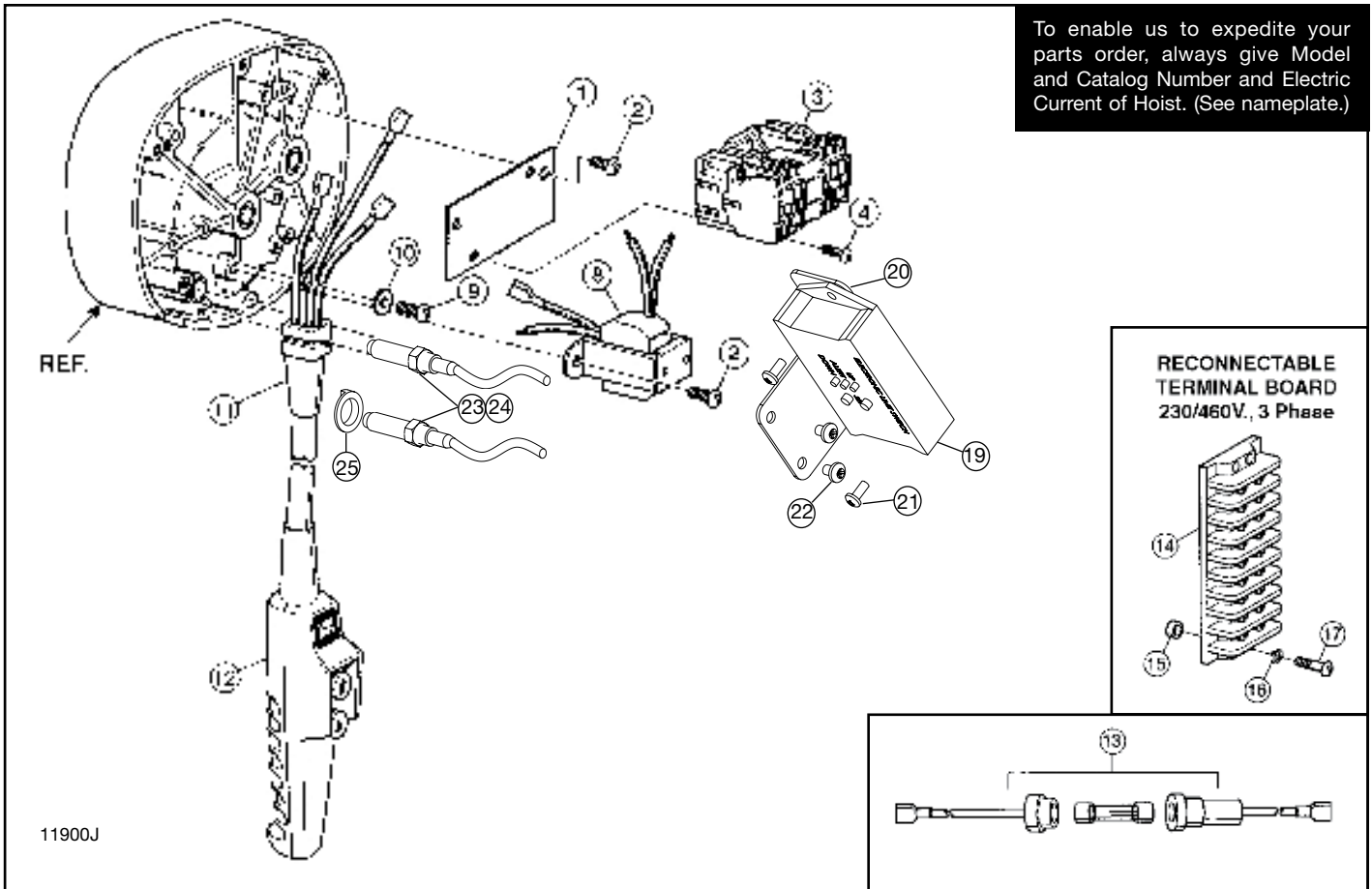

Figure 9-7b. ELECTRICAL CONTROL UNITS (Three phase Single Speed Hoists, Electronic Limit Switch)

| Ref. No. | Part Number   | Description  | Qty. Req'd                |
|----------|---------------|--|---------------------------|
| 1        | BH-3800       | Contactor and Mounting Plate Assembly (Includes Ref. Nos. 1, 3 and 4)  | 1                         |
|          | BH-3801       | Three Phase 24V Control  |                           |
|          | BH-3802       | Three Phase 115V Control   |                           |
|          | BH-3802       | Mounting Plate - Contactor   | 1                         |
| 2        | BH-2155       | Sems Round Head Machine Screw with External Lock Washer (#10-24 x 3/8) | 5                         |
| 3        |               | Contactor Assembly   | 1                         |
| 4        | BH-3803       | Three Phase 24V Control  |                           |
|          | BH-3804       | Three Phase 115V Control   |                           |
| 8        | BH-2189       | Pan Head Self Tapping Screw (#8-32 x 1/2)                              | 2                         |
| 9        |               | Transformer  | 1                         |
|          | BH-2166       | Three Phase 208V/24V   |                           |
|          | BH-3805       | Three Phase 230V/460V/24V  |                           |
|          | BH-2168       | Three Phase 575V/24V   |                           |
|          | BH-2169       | Three Phase 208V/115V  |                           |
|          | BH-3806       | Three Phase 230V/460V/115V   |                           |
|          | BH-2172       | Three Phase 575V/115V  |                           |
|          | BH-2173       | Sems Round Head Machine Screw with External Lock Washer (1/4-20 x 5/8) | 1                         |
|          | 10            | BH-2174  | Plain Washer (Type N 1/4) |
| 11       | BH-2175       | Grommet  | 1                         |
| 12       | See Fig. 9-12 | Push Button Station and Conductor Cable Assembly                       | 1                         |
| 13       |               | Fuse, Fuse Holder and Wire Assembly                                    | 1                         |
|          | BH-2176       | 3A/250V  | 1                         |
|          | BH-2177       | 1/2A/250V  |                           |
|          |               | Fuse Only  | 1                         |
|          | BH-2178       | 3A/250V Rating   |                           |
|          | BH-2179       | 1/2A/250V Rating   |                           |

(Continued on following page)





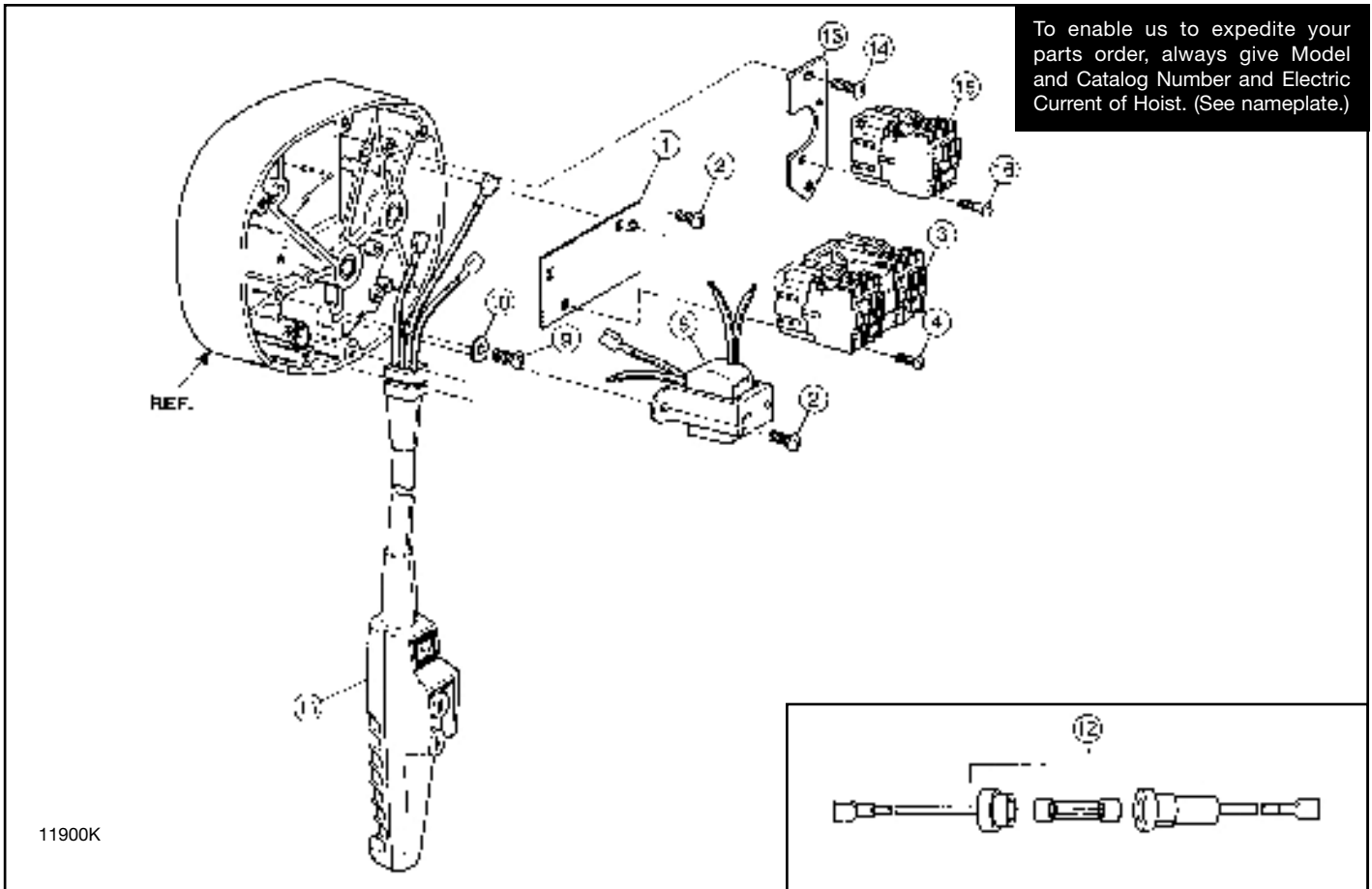

Figure 9-8a. ELECTRICAL CONTROL UNITS (Two Speed Hoists Only, Paddle Limit)

| Ref. No. | Part Number   | Description   | Qty. Req'd |  |
|----------|---|---|------------|--|
| 1        | BH-3800   | Contractor and Mounting Plate Assembly (Includes Ref. Nos. 1, 3 and 4)<br>Three Phase 24V Control | 1          |  |
|          | BH-3801   |   |            | Three Phase 115V Control                         |
|          | BH-3802   |   |            | Mounting Plate - Contactor                       |
|          | BH-2155   |   |            | Sems Round Head Machine Screw with External Lock |
| 2        | BH-2155   | Washer (#10-24 x 3/8)   | 5          |  |
|          |   | Contactor Assembly  | 1          |  |
| 3        | BH-3803   | Three Phase 24V Control   | 2          |  |
|          | BH-3804   | Three Phase 115V Control  |            |  |
| 4        | BH-2189   | Pan Head Self Tapping Screw (#8-32 x 1/2)   | 2          |  |
| 5        | BH-2161   | Hex Socket Head Cap Screw (#10-24 x 3/8 Pltd.)  | 2          |  |
| 6        | BH-2162   | Regular Helical Spring Lock Washer (#10 Pltd.)  | 2          |  |
| 7        | See Fig. 9-11   | Limit Switch and Shaft Assembly   | 1          |  |
| 8        | BH-2166<br>BH-2164<br>BH-2167<br>BH-2168<br>BH-2169<br>BH-2170<br>BH-2171<br>BH-2172<br>BH-2173 | Transformer   | 1          |  |
|          |   | Three Phase 208V/24V  |            |  |
|          |   | Three Phase 230V/24V  |            |  |
|          |   | Three Phase 460V/24V  |            |  |
|          |   | Three Phase 575V/24V  |            |  |
|          |   | Three Phase 208/115V  |            |  |
|          |   | Three Phase 230V/115V   |            |  |
|          |   | Three Phase 460V/115V   |            |  |
|          |   | Three Phase 575V/115V   |            |  |
|          |   | Three Phase 208/115V  |            |  |
| 9        | BH-2173   | Sems Round Head Machine Screw with External Lock  | 1          |  |
|          |   | Washer (1/4-20 x 5/8)   |            |  |
| 10       | BH-2174   | Plain Washer (Type N 1/4)   | 2          |  |
| 11       | See Fig. 9-13   | Push Button Station and Conductor Cable Assembly  | 1          |  |

(Continued on following page)

**Figure 9-8a. ELECTRICAL CONTROL UNITS - Continued**

| <b>Ref. No.</b> | <b>Part Number</b> | <b>Description</b>   | <b>Qty. Req'd</b> |
|-----------------|--------------------|--|-------------------|
| 12              | BH-2176            | Fuse, Fuse Holder and Wire Assembly                                      | 1                 |
|                 | BH-2177            | 3A/250V<br>1/2A/250V   |                   |
|                 | BH-2178            | Fuse Only  | 1                 |
|                 | BH-2179            | 3A/250V Rating<br>1/2A/250V Rating                                       |                   |
|                 | BH-3809            | Contactor and Mounting Plate Assembly (Includes Ref. Nos. 13, 15 and 16) | 1                 |
|                 | BH-3810            | Three Phase 24V Control  |                   |
|                 | BH-3811            | Three Phase 115V Control   |                   |
| 13              | BH-3811            | Mounting Plate - Contactor   | 1                 |
| 14              | BH-2193            | Sems Round Head Machine Screw with External Lock                         |                   |
|                 |                    | Washer (#8-32 x 1/2)   | 2                 |
| 15              |                    | Contactor Assembly   | 1                 |
|                 | BH-3812            | Three Phase 24V Control  |                   |
|                 | BH-3813            | Three Phase 115V Control   |                   |
| 16              | BH-2199            | Pan Head Self Tapping Screw (#8-32 x 3/8)                                | 2                 |
| 17              | BH-1422            | Flanged Sleeve Bearing   | 1                 |

**Note:** Replacement fuses are standard automotive type and may be purchased locally.

**NOTES**

---

---

---

---

---

---

---

---

---

---

---

---

---

---

---

---

---

---

---

---

---

---

---

---

---

---

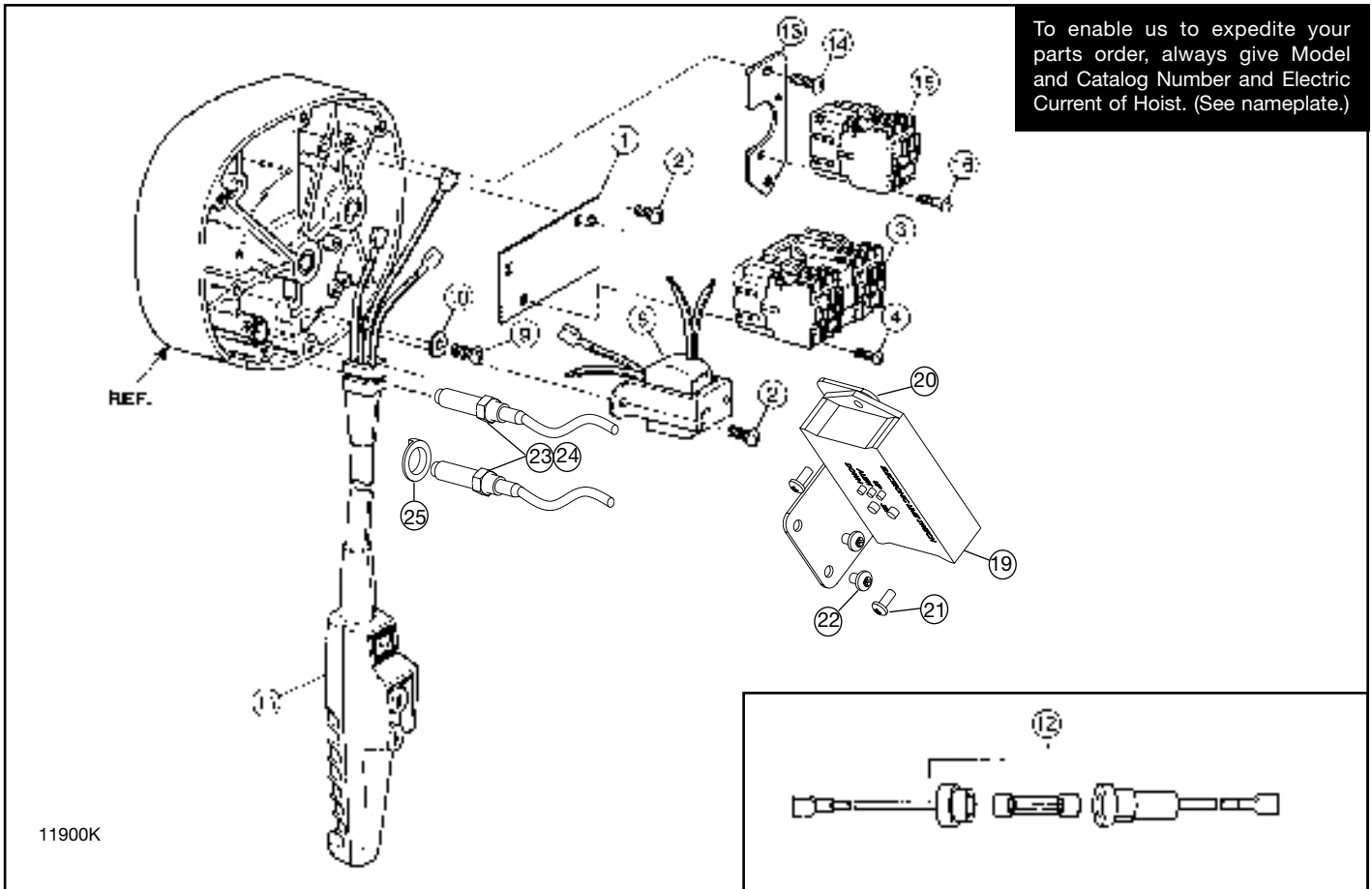

Figure 9-8b. ELECTRICAL CONTROL UNITS (Two Speed Hoists Only, Electronic Limit Switch)

| Ref. No. | Part Number   | Description  | Qty. Req'd |
|----------|---------------|--|------------|
| 1        | BH-3800       | Contractor and Mounting Plate Assembly (Includes Ref. Nos. 1, 3 and 4) | 1          |
|          | BH-3801       |  |            |
|          | BH-3802       |  |            |
| 2        | BH-2155       | Sems Round Head Machine Screw with External Lock                       | 1          |
| 3        |               | Washer (#10-24 x 3/8)  | 5          |
|          |               | Contactor Assembly   | 1          |
| 4        | BH-3803       | Three Phase 24V Control  | 1          |
|          | BH-3804       | Three Phase 115V Control   |            |
| 8        | BH-2189       | Pan Head Self Tapping Screw (#8-32 x 1/2)                              | 2          |
| 9        |               | Transformer  | 1          |
|          | BH-2166       | Three Phase 208V/24V   | 1          |
|          | BH-2164       | Three Phase 230V/24V   |            |
|          | BH-2167       | Three Phase 460V/24V   |            |
|          | BH-2168       | Three Phase 575V/24V   |            |
|          | BH-2169       | Three Phase 208/115V   |            |
|          | BH-2170       | Three Phase 230V/115V  |            |
|          | BH-2171       | Three Phase 460V/115V  |            |
|          | BH-2172       | Three Phase 575V/115V  |            |
|          | BH-2173       | Sems Round Head Machine Screw with External Lock                       |            |
| 10       | BH-2174       | Washer (1/4-20 x 5/8)  |            |
| 11       |               | Plain Washer (Type N 1/4)  | 2          |
|          | See Fig. 9-13 | Push Button Station and Conductor Cable Assembly                       | 1          |

(Continued on following page)

Figure 9-8b. ELECTRICAL CONTROL UNITS - Continued

| Ref. No. | Part Number | Description  | Qty. Req'd |
|----------|-------------|--|------------|
| 12       | BH-2176     | Fuse, Fuse Holder and Wire Assembly  | 1          |
|          | BH-2177     | 3A/250V<br>1/2A/250V   |            |
|          | BH-2178     | Fuse Only  | 1          |
|          | BH-2179     | 3A/250V Rating<br>1/2A/250V Rating   |            |
|          | BH-3809     | Contactator and Mounting Plate Assembly (Includes Ref. Nos. 13, 15 and 16) | 1          |
|          | BH-3810     | Three Phase 24V Control  |            |
|          | BH-3811     | Three Phase 115V Control   |            |
| 13       | BH-3811     | Mounting Plate - Contactator   | 1          |
| 14       | BH-2193     | Sems Round Head Machine Screw with External Lock                           |            |
|          |             | Washer (#8-32 x 1/2)   | 2          |
| 15       |             | Contactator Assembly   | 1          |
|          | BH-3812     | Three Phase 24V Control  |            |
|          | BH-3813     | Three Phase 115V Control   |            |
| 16       | BH-2199     | Pan Head Self Tapping Screw (#8-32 x 3/8)                                  | 2          |

Note: Replacement fuses are standard automotive type and may be purchased locally.

NOTES

---

---

---

---

---

---

---

---

---

---

---

---

---

---

---

---

---

---

---

---

---

---

---

---

To enable us to expedite your parts order, always give Model and Catalog Number and Electric Current of Hoist. (See nameplate.)

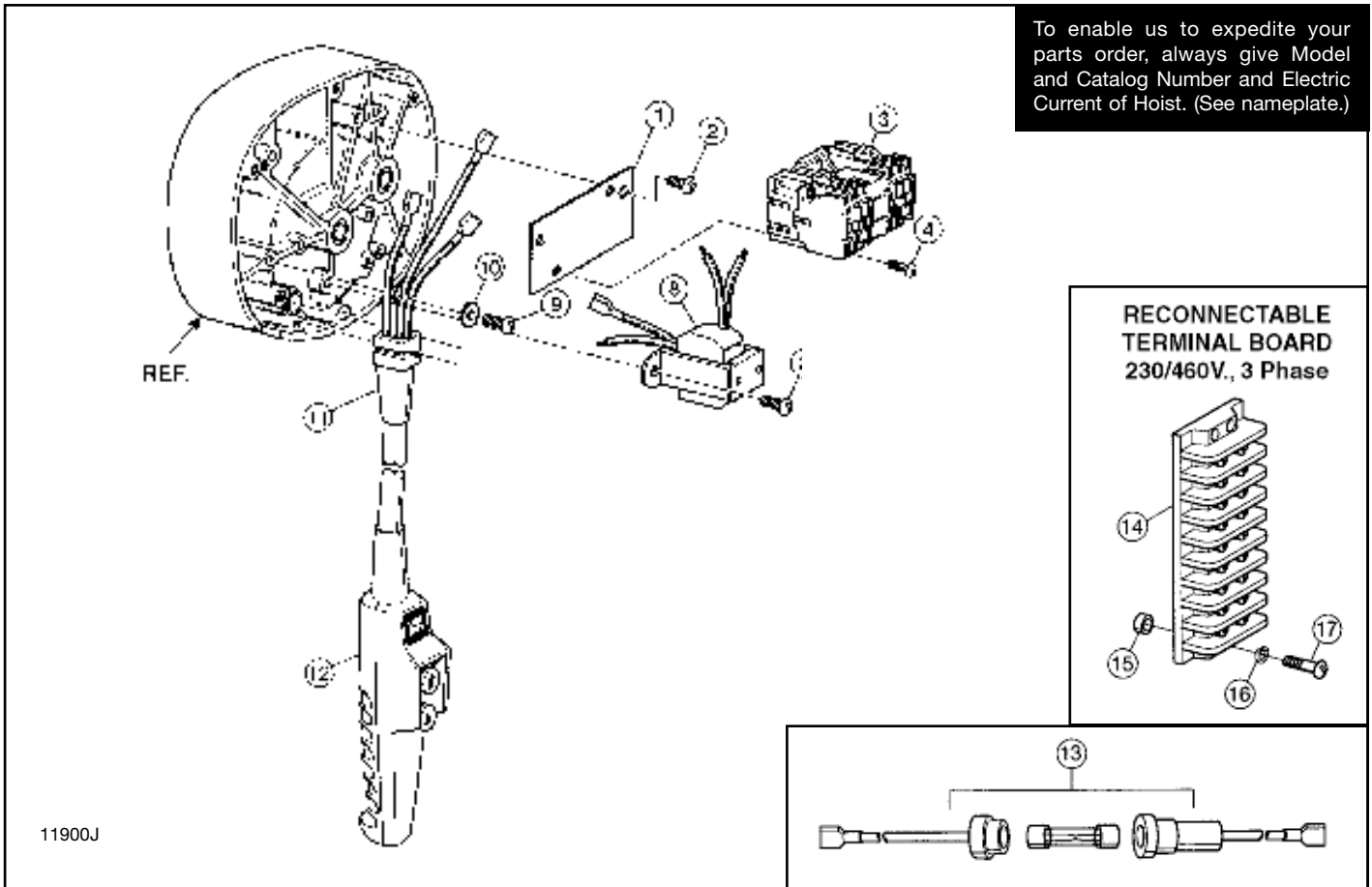

Figure 9-9a. ELECTRICAL CONTROL UNITS (Single Phase Hoists, Paddle Limit)

| Ref. No. | Part Number   | Description  | Qty. Req'd |
|----------|---------------|--|------------|
| 1        | BH-3800       | Contractor and Mounting Plate Assembly (Includes Ref. Nos. 1, 3 and 4)<br>1/4, 1/2 & 1 HP<br>Single Phase 24V Control<br>Single Phase 115V Control<br>2-1/4 HP Only<br>Single Phase 24V Control<br>Single Phase 115V Control | 1          |
|          | BH-3801       |  |            |
|          | BH-3814       |  |            |
|          | BH-3815       |  |            |
|          | BH-3802       |  |            |
|          | BH-2155       |  |            |
|          | BH-3803       |  |            |
|          | BH-3804       |  |            |
|          | BH-3816       |  |            |
|          | BH-3817       |  |            |
| 4        | BH-2189       | Pan Head Self Tapping Screw (#8-32 x 1/2)  | 2          |
| 5        | BH-2161       | Hex Socket Head Cap screw (#10-24 x 3/8 Pltd.)   | 2          |
| 6        | BH-2162       | Regular Helical Spring Lock Washer (#10 Pltd.)   | 2          |
| 7        | See Fig. 9-11 | Limit Switch and Shaft Assembly  | 1          |
| 8        |               | Transformer  | 1          |
| 9        | BH-3818       | Single Phase 115V/230V/24V   | 1          |
|          | BH-3819       | Single Phase 115V/230V/115V  |            |
|          | BH-2173       | Sems Round Head Machine Screw with External Lock<br>Washer (1/4-20 x 5/8)  |            |

(Continued on following page)

Figure 9-9a. ELECTRICAL CONTROL UNITS - Continued

| Ref. No. | Part Number   | Description                                      | Qty. Req'd |
|----------|---------------|--|------------|
| 10       | BH-2174       | Plain Washer (Type N 1/4)                        | 2          |
| 11       | BH-2175       | Grommet  | 1          |
| 12       | See Fig. 9-12 | Push Button Station and Conductor Cable Assembly | 1          |
| 13       |               | Fuse, Fuse Holder and Wire Assembly              | 1          |
|          | BH-2176       | 3A/250V  |            |
|          | BH-2177       | 1/2A/250V  |            |
|          |               | Fuse Only  | 1          |
|          | BH-2178       | 3A/250V Rating                                   |            |
|          | BH-2179       | 1/2A/250V Rating                                 |            |
| 14       | BH-3807       | Block-Terminal                                   | 1          |
| 15       | BH-2181       | Spacer-Terminal Block                            | 2          |
| 16       | BH-2182       | Regular Helical Spring Lock Washer (#8 Pltd.)    | 2          |
| 17       | BH-3820       | Pan Head Self Tapping Screw (#8-32 x 5/8 Pltd.)  | 2          |
| 18       | BH-1422       | Flanged Sleeve Bearing                           | 1          |

Note: Replacement fuses are standard automotive type and may be purchased locally.

NOTES

---

---

---

---

---

---

---

---

---

---

---

---

---

---

---

---

---

---

---

---

---

---

---

---

---

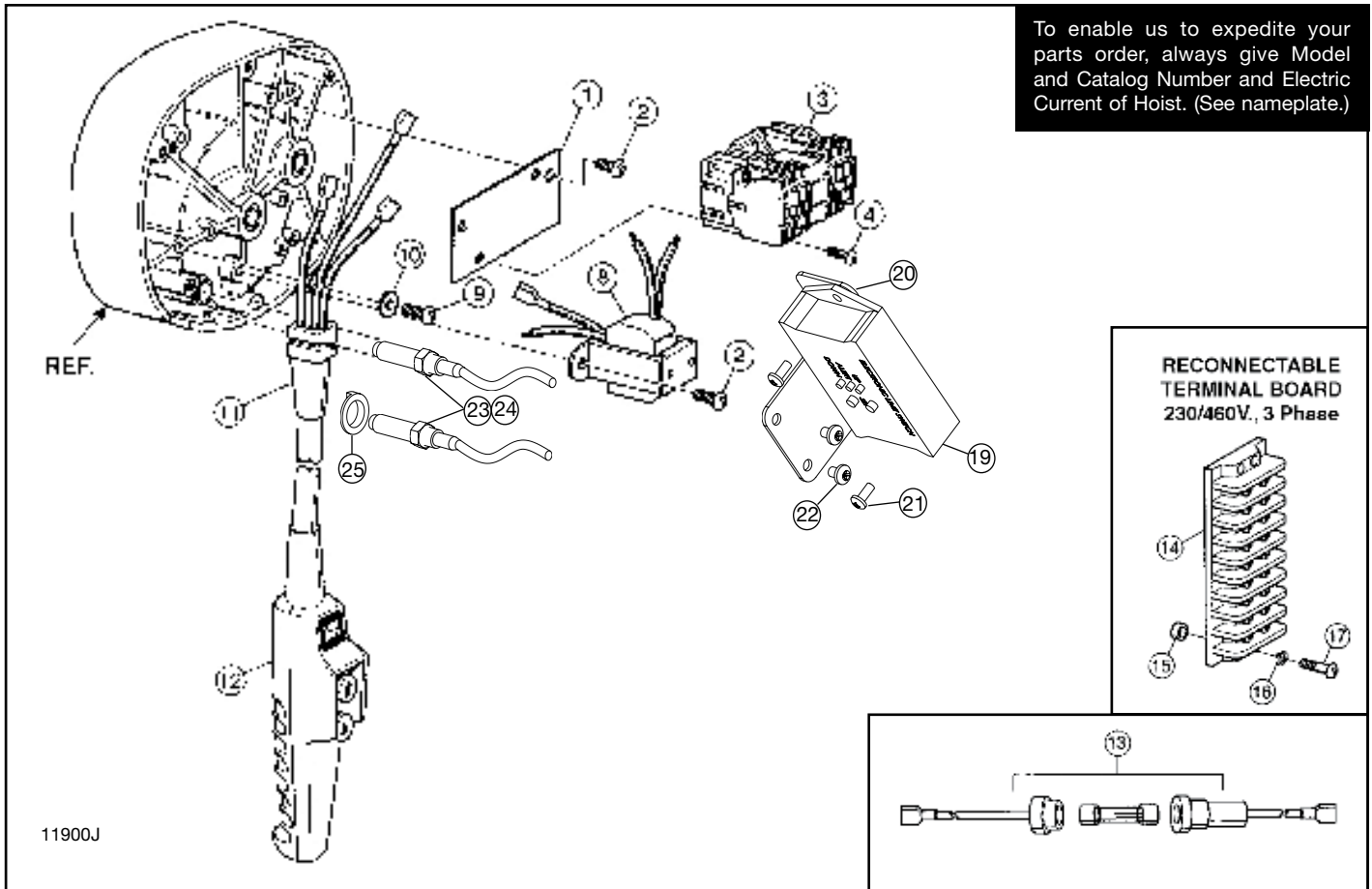

Figure 9-9b. ELECTRICAL CONTROL UNITS (Single Phase Hoists, Electronic Limit Switch)

| Ref. No. | Part Number   | Description  | Qty. Req'd |   |  |   |
|----------|---------------|--|------------|---|--|---|
| 1        | BH-3800       | Contractor and Mounting Plate Assembly (Includes Ref. Nos. 1, 3 and 4)<br>1/4, 1/2 & 1 HP<br>Single Phase 24V Control<br>Single Phase 115V Control<br>2-1/4 HP Only<br>Single Phase 24V Control<br>Single Phase 115V Control<br>Mounting Plate - Contactor | 1          |   |  |   |
|          | BH-3801       |  |            |   |  |   |
|          | BH-3814       |  |            |   |  |   |
|          | BH-3815       |  |            |   |  |   |
|          | BH-3802       |  |            |   |  |   |
|          | BH-2155       |  |            | Sems Round Head Machine Screw with External Lock<br>Washer (#10-24 x 3/8) | 4  |   |
|          | 3             |  |            | BH-3803   | Contactor Assembly<br>1/4, 1/2 & 1 HP<br>Single Phase 24V Control<br>Single Phase 115V Control<br>2-1/4 HP Only<br>Single Phase 24V Control<br>Single Phase 115V Control | 1 |
|          |               |  |            | BH-3804   |  |   |
|          |               |  |            | BH-3816   |  |   |
|          | 4             |  |            | BH-3817   | Pan Head Self Tapping Screw (#8-32 x 1/2)  | 2 |
|          |               |  |            | BH-2189   |  |   |
|          | 8             |  |            | BH-3818   | Transformer<br>Single Phase 115V/230V/24V<br>Single Phase 115V/230V/115V   | 1 |
| BH-3819  |               |  |            |   |  |   |
| BH-2173  |               | Sems Round Head Machine Screw with External Lock<br>Washer (1/4-20 x 5/8)  | 1          |   |  |   |
| 10       | BH-2174       | Plain Washer (Type N 1/4)  | 2          |   |  |   |
| 11       | BH-2175       | Grommet  | 1          |   |  |   |
| 12       | See Fig. 9-12 | Push Button Station and Conductor Cable Assembly   | 1          |   |  |   |

(Continued on following page)





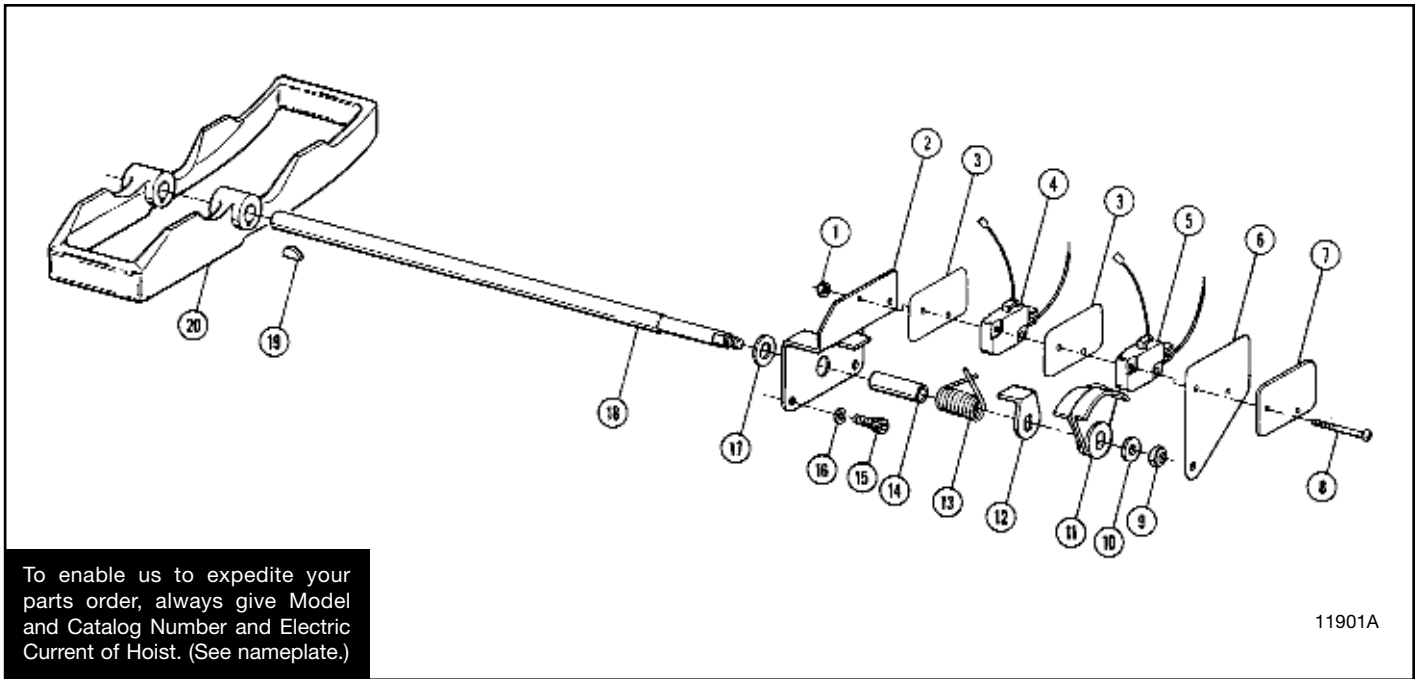
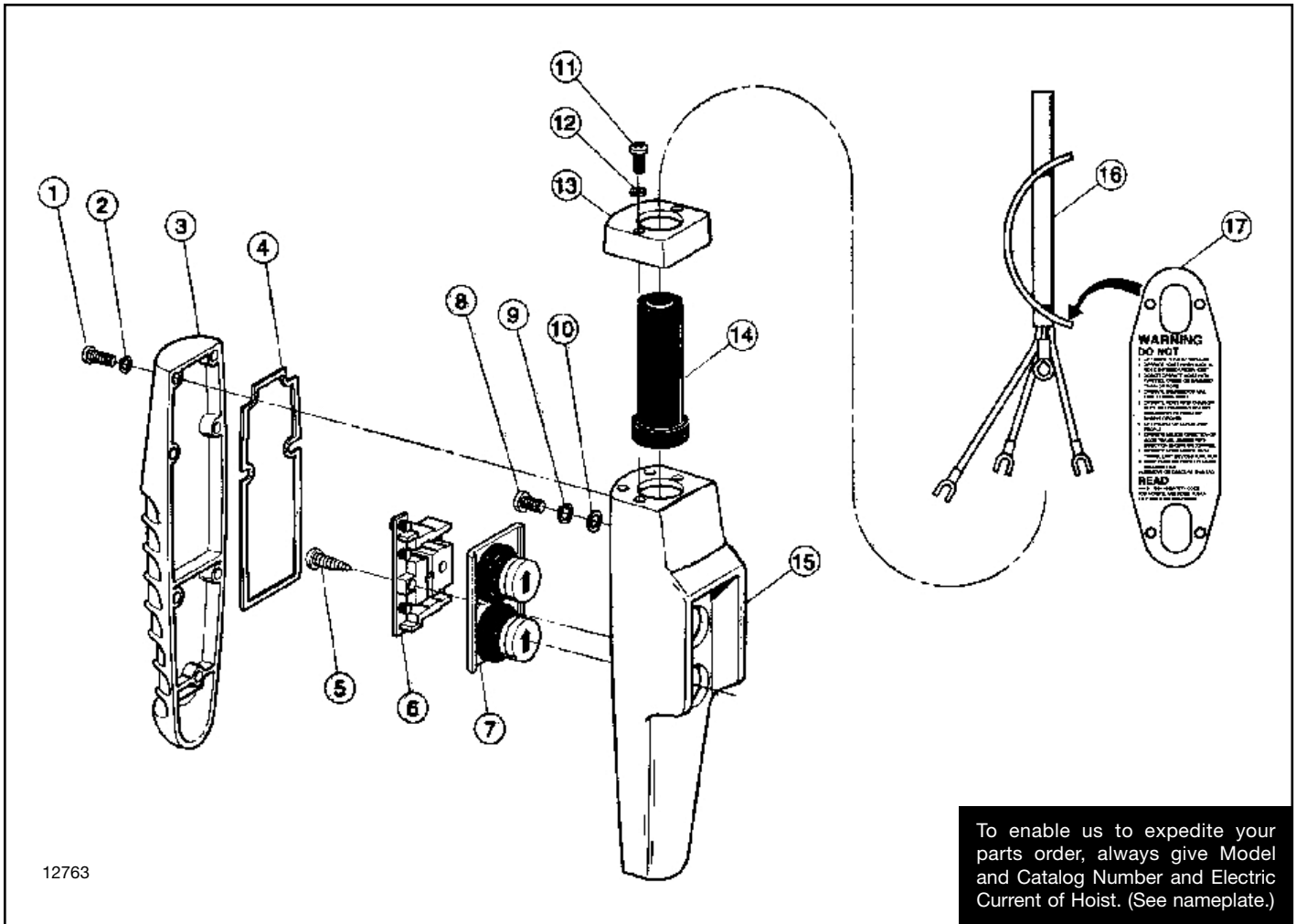

Figure 9-10. LIMIT LEVER AND SWITCH PARTS (If Equipped)

| Ref. No. | Part Number | Description  | Qty. Req'd |
|----------|-------------|--|------------|
|          | BH-1850     | Limit Switch and Shaft Assembly (Includes Ref. Nos. 1 thru 14 and 17 and 18) | 1          |
| 1        | BH-1851     | Light Hex Self-locking Nut (#4-40 Pltd.)                                     | 2          |
| 2        | BH-1852     | Retainer   | 1          |
| 3        | BH-1853     | Insulation   | 2          |
| 4        | BH-1854     | Limit Switch-Upper   | 1          |
| 5        | BH-1855     | Limit Switch-Lower   | 1          |
| 6        | BH-1856     | Insulation   | 1          |
| 7        | BH-1857     | Plate-Cover  | 1          |
| 8        | BH-1858     | Round Head Machine Screw (#40-40 x 1-1/8 Pltd.)                              | 2          |
| 9        | BH-1859     | Light Thin Hex Self-locking Nut (#10-24 Pltd.)                               | 1          |
| 10       | BH-1860     | Plain Washer (#10 Pltd.)   | 1          |
| 11       | BH-1861     | Switch Actuator  | 1          |
| 12       | BH-1862     | Centering Lever  | 1          |
| 13       | BH-1863     | Spring-Control   | 1          |
| 14       | BH-1864     | Spacer   | 1          |
| 15       | BH-1865     | Hex Socket Head Cap Screw (#10-24 x 3/8 Pltd.)                               | 2          |
| 16       | BH-1866     | Regular Helical Spring Lock Washer (#10 Pltd.)                               | 2          |
| 17       | BH-1867     | Plain Washer (Type N 5/16 Pltd.)   | 1          |
| 18       | BH-1868     | Control Shaft  | 1          |
| 19       | BH-1869     | Key-Woodruff   | 1          |
| 20       | BH-1870     | Limit Lever  | 1          |



12763

To enable us to expedite your parts order, always give Model and Catalog Number and Electric Current of Hoist. (See nameplate.)

**Figure 9-11. PUSH BUTTON STATION AND CONDUCTOR CABLE ASSEMBLY (Single Speed Hoists)**

| Ref. No. | Part Number | Description   | Qty. Req'd |
|----------|-------------|---|------------|
|          | BH-3401     | Push Button Station and Conductor Cable Assembly (Includes Ref. Nos. 1 thru 17) | 1          |
|          | BH-3402     | Push Button Station (Includes Ref. Nos. 1 thru 15)                              | 1          |
| 1        | *           | Type 1 Pan Head Machine Screw (M3.5 x 0.6 x 12 Pltd.)                           | 7          |
| 2        | *           | Lockwasher (M 3.5 Pltd.)  | 7          |
| 3        | *           | Rear Cover  | 1          |
| 4        | BH-3403     | Gasket  | 1          |
| 5        | *           | Type I Pan Head Thread Cutting Screw (M 4 x 15 Pltd.)                           | 2          |
| 6        | BH-3404     | Contact Assembly  | 1          |
| 7        | BH-3405     | Button Assembly   | 1          |
| 8        | *           | Type 1 Pan Head Machine Screw (M 6 x 1 x 12 Pltd.)                              | 1          |
| 9        | *           | Lockwasher (M 6 Pltd.)  | 1          |
| 10       | *           | Plain Washer (M 6 Pltd.)  | 1          |
| 11       | *           | Type 1 Pan Head Machine Screw (M 3.5 x 1 x 14 Pltd.)                            | 2          |
| 12       | *           | Lockwasher (M 3.5 Pltd.)  | 2          |
| 13       | *           | Housing Cap   | 1          |
| 14       | BH-3406     | Grommet   | 1          |
| 15       | *           | Housing   | 1          |
| 16       | BH-3407     | Conductor Cable Assembly  | 1          |
| 17       | BH-3408     | Plastic Warning Tag   | 1          |

\* Not available separately. Order Push Button Station.

To enable us to expedite your parts order, always give Model and Catalog Number and Electric Current of Hoist. (See nameplate.)

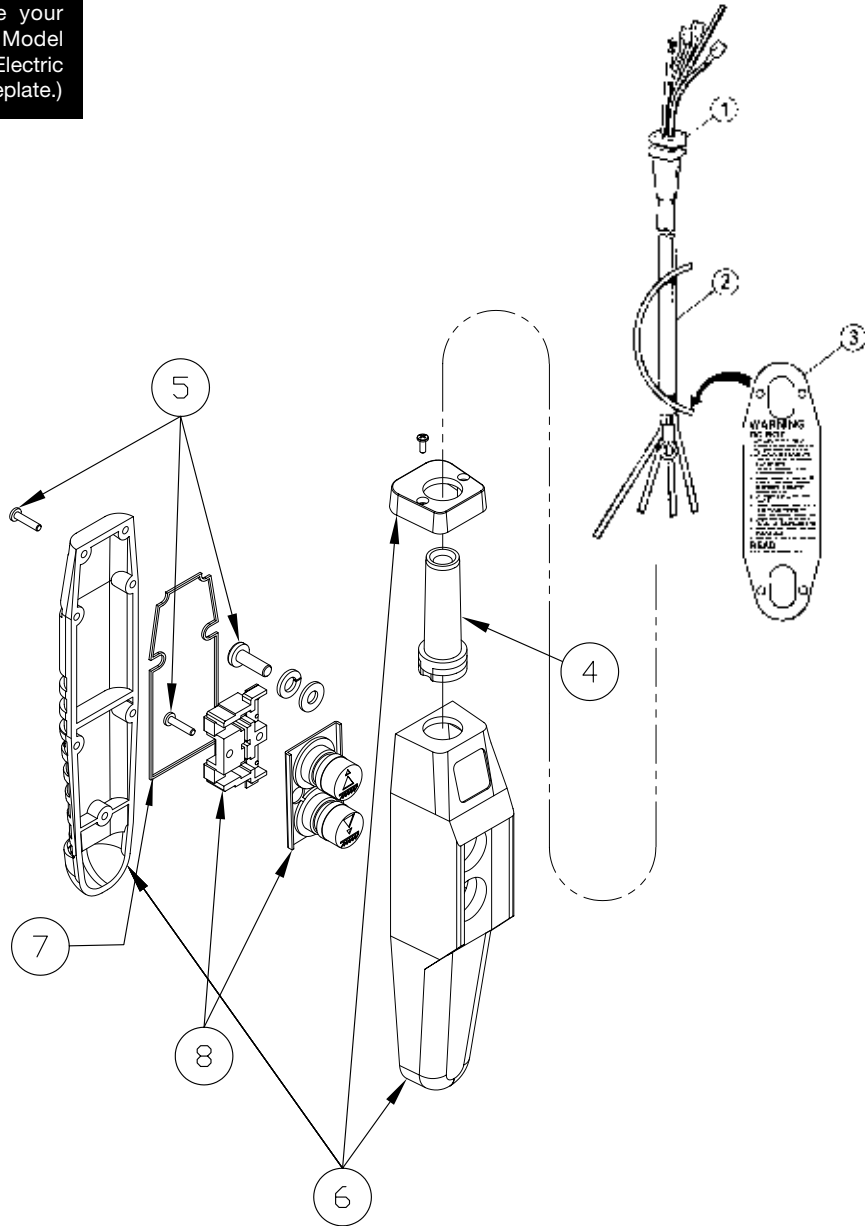

12721A

**Figure 9-12. PUSH BUTTON STATION AND CONDUCTOR CABLE ASSEMBLY  
(Two Speed Hoists Only)**

| Ref. No. | Part Number | Description  | Qty. Req'd |
|----------|-------------|--|------------|
|          | BH-4027     | Push Button Station and Conductor Cable Assembly<br>(Includes Ref. Nos. 1 thru 30) | 1          |
| 1        | BH-1981     | Grommet  | 1          |
| 2        | BH-1982     | Conductor Cable  | 1          |
| 3        | BH-1971     | Operator Warning Label   | 1          |
|          | BH-4029     | Push Button Station (Includes Ref. Nos. 12 thru 30)                                | 1          |
| 4        | BH-4030     | Control Station Grommet  | 1          |
| 5        | *           | Control Station Hardware   | 4          |
| 6        | *           | Control Station Housing  | 4          |
| 7        | BH-3403     | Gasket   | 1          |
| 8        | BH-4028     | Button and Control Assembly  | 1          |
|          |             | Contact Block  | 2          |
|          |             | Contact Block  | 2          |

\* Not available separately. Order Push Button Station.

\*\* Not available separately. Order Push Button Assembly.

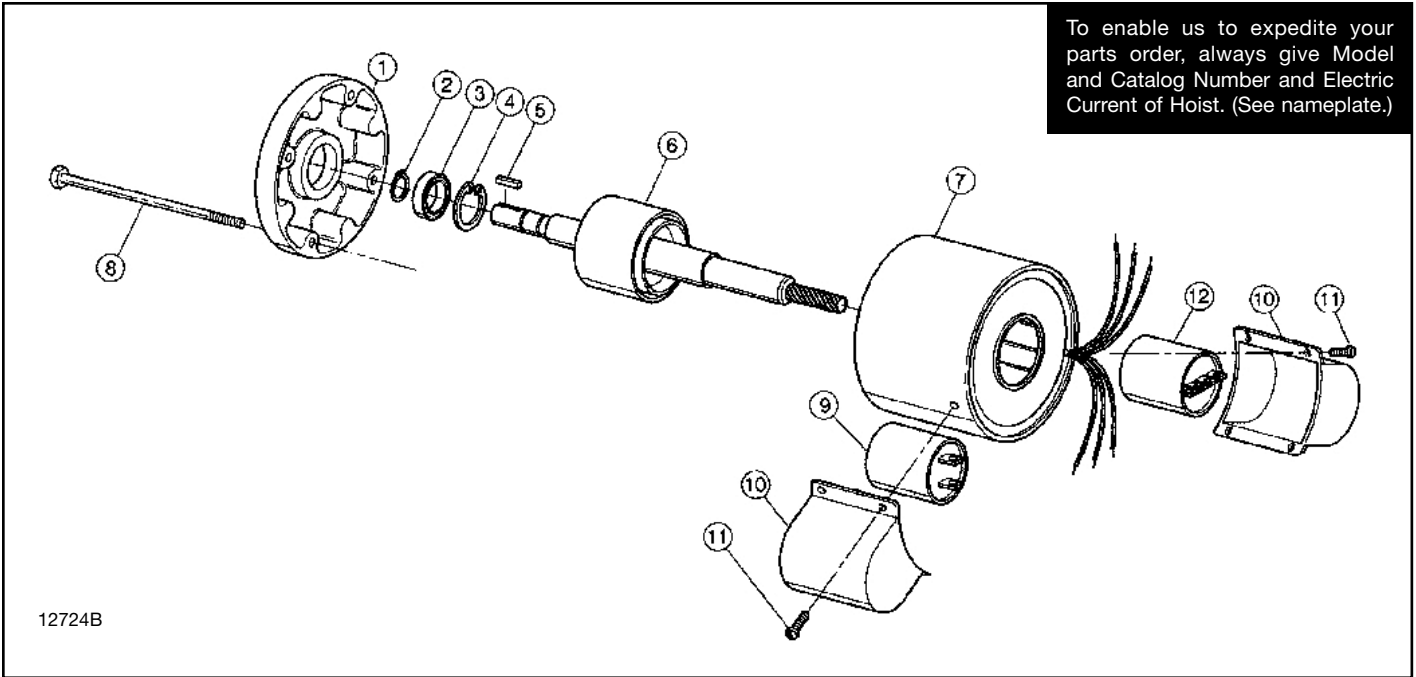

To enable us to expedite your parts order, always give Model and Catalog Number and Electric Current of Hoist. (See nameplate.)

12724B

Figure 9-13. SINGLE PHASE MOTOR ASSEMBLY

| Ref. No. | Part Number | Description  | Primer  | Qty. Req'd |
|----------|-------------|--|---------|------------|
|          |             | Motor Assembly (Includes Ref. Nos. 1 thru 12)      |         | 1          |
|          | BH-4031     | 1/4 Horsepower - Yellow Powercoat                  | BH-4034 |            |
|          | BH-4032     | 1/2 Horsepower - Yellow Powercoat                  | BH-4035 |            |
|          | BH-4033     | 1 Horsepower - Yellow Powercoat                    | BH-4036 |            |
|          | BH-3903     | 2-1/4 Horsepower                                   |         |            |
| 1        | *           | Bell - End   |         | 1          |
| 2        | *           | Ring - Retaining                                   |         | 1          |
| 3        | *           | Bearing - Ball                                     |         | 1          |
| 4        | *           | Ring - Retaining                                   |         | 1          |
| 5        | BH-3908     | Key - Brake  |         | 1          |
| 6        | *           | Rotor and Shaft Assembly                           |         | 1          |
| 7        | *           | Stator Assembly                                    |         | 1          |
| 8        |             | Bolt - Motor Mounting                              |         | 4          |
|          | BH-3909     | 1/4 Horsepower                                     |         |            |
|          | BH-3910     | 1/2 Horsepower                                     |         |            |
|          | BH-3911     | 1 Horsepower                                       |         |            |
| 9        |             | Capacitor Assembly                                 |         | 1          |
|          | BH-3913     | 1/4 Horsepower                                     |         |            |
|          | BH-3914     | 1/2 Horsepower                                     |         |            |
|          | BH-3915     | 1 Horsepower                                       |         |            |
| 10       |             | Cover  |         | 1          |
|          |             | For Ref. No. 9                                     |         |            |
|          | *           | 1/4 Horsepower                                     |         |            |
|          | *           | 1/2 Horsepower                                     |         |            |
|          | *           | 1 Horsepower                                       |         |            |
|          | BH-3919     | For Ref. No. 12                                    |         |            |
| 11       | BH-3920     | Slotted Hex Head Self Tapping Screw (#8-32 x 5/16) |         | 2          |
| 12       |             | Solid State Switch Assembly                        |         | 1          |
|          | BH-3921     | 1/4, 1/2 & 1 Horsepower                            |         |            |

\* Furnished only as part of motor assembly.

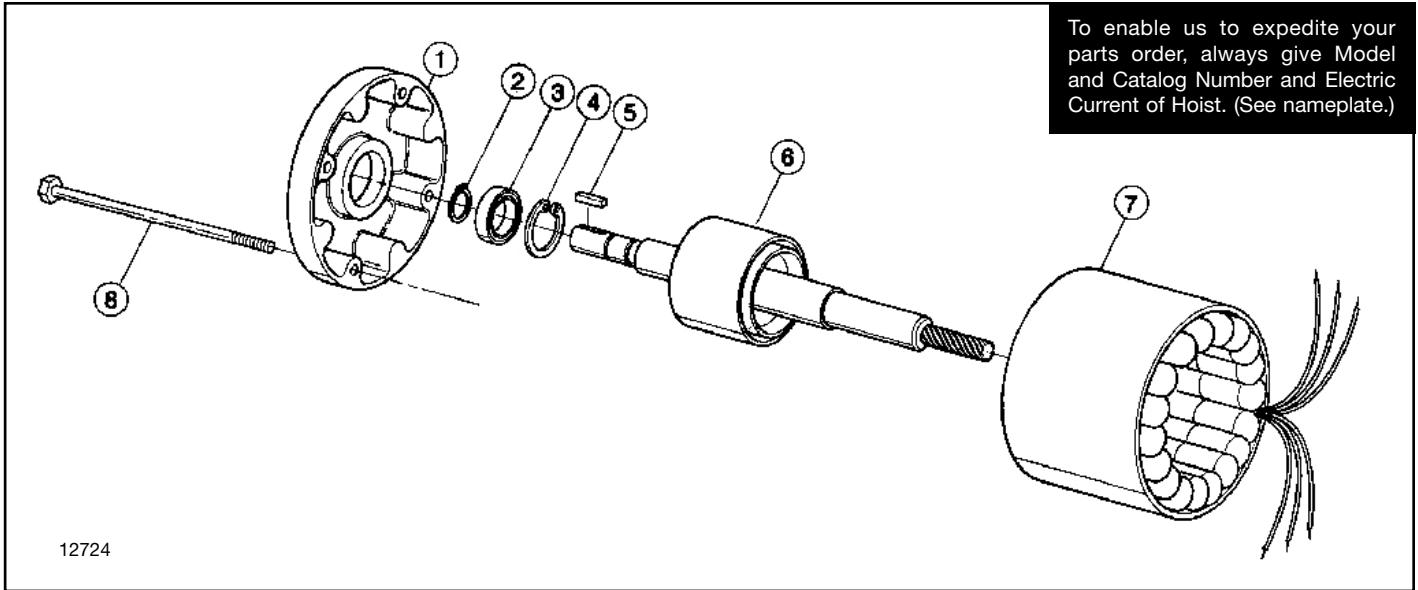

Figure 9-14. THREE PHASE MOTOR ASSEMBLY

| Ref. No. | Part Number | Description   | Primer  | Qty. Req'd |
|----------|-------------|---|---------|------------|
|          |             | Motor Assembly (Includes Ref. Nos. 1 thru 8)        |         | 1          |
|          | BH-4037     | 1/4 Horsepower (1 Speed) - Yellow Powercoat         | BH-4050 |            |
|          | BH-4038     | 200 Volt  | BH-4051 |            |
|          | BH-4039     | 230/460 Volt  | BH-4052 |            |
|          |             | 575 Volt  |         |            |
|          |             | 1/2 Horsepower (1 Speed) - Yellow Powercoat         |         |            |
|          | BH-4053     | 200 Volt  | BH-4056 |            |
|          | BH-4054     | 230/460 Volt  | BH-4057 |            |
|          | BH-4055     | 575 Volt  | BH-4058 |            |
|          |             | 1 Horsepower (1 Speed) - Yellow Powercoat           |         |            |
|          | BH-4059     | 200 Volt  | BH-4062 |            |
|          | BH-4060     | 230/460 Volt  | BH-4063 |            |
|          | BH-4061     | 575 Volt  | BH-4064 |            |
|          |             | 2-1/2 Horsepower (1 Speed) - Yellow Powercoat       |         |            |
|          | BH-4065     | 200 Volt  | BH-4068 |            |
|          | BH-4066     | 230/460 Volt  | BH-4069 |            |
|          | BH-4067     | 575 Volt  | BH-4070 |            |
|          |             | 1/2-1/6 Horsepower (2 Speed) - Yellow Powercoat     |         |            |
|          | BH-4071     | 200 Volt  | BH-4075 |            |
|          | BH-4072     | 230 Volt  | BH-4076 |            |
|          | BH-4073     | 460 Volt  | BH-4077 |            |
|          | BH-4074     | 575 Volt  | BH-4078 |            |
|          |             | 1-1/3 Horsepower (2 Speed) - Yellow Powercoat       |         |            |
|          | BH-4079     | 200 Volt  | BH-4083 |            |
|          | BH-4080     | 230 Volt  | BH-4084 |            |
|          | BH-4081     | 460 Volt  | BH-4085 |            |
|          | BH-4082     | 575 Volt  | BH-4086 |            |
|          |             | 2-1/4 - 3/4 Horsepower (2 Speed) - Yellow Powercoat |         |            |
|          | BH-4087     | 200 Volt  | BH-4091 |            |
|          | BH-4088     | 230 Volt  | BH-4092 |            |
|          | BH-4089     | 460 Volt  | BH-4093 |            |
|          | BH-4090     | 575 Volt  | BH-4094 |            |
| 1        |             | Bell - End  |         | 1          |
|          | *           | 1 Speed - 1/4, 1/2 and 1 HP                         |         |            |
|          | *           | 1 Speed - 2-1/2 HP                                  |         |            |
|          | *           | 2 Speed   |         |            |

(Continued on following page)

Figure 9-14. THREE PHASE MOTOR ASSEMBLY - Continued

| Ref. No. | Part Number                   | Description   | Qty. Req'd |
|----------|-------------------------------|---|------------|
| 2        | *<br>*<br>*                   | Ring - Retaining<br>1 Speed- 1/4, 1/2 and 1 HP<br>1 Speed - 2-1/2 HP<br>2 Speed       | 1          |
| 3        | BH-3312<br>BH-2915<br>BH-2915 | Bearing - Ball<br>1 Speed - 1/4, 1/2 and 1 HP<br>1 Speed - 2-1/2 HP<br>2 Speed        | 1          |
| 4        | *<br>*<br>*                   | Ring - Retaining<br>1 Speed - 1/4, 1/2 and 1 HP<br>1 Speed - 2-1/2 HP<br>2 Speed      | 1          |
| 5        | BH-3314<br>BH-2917<br>BH-2917 | Key - Brake<br>1 Speed - 1/4,1/2 and 1 HP<br>1 Speed - 2-1/2 HP<br>2 Speed            | 1          |
| 6        | *                             | Rotor and Shaft Assembly  | 1          |
| 7        | *                             | Stator Assembly   | 1          |
| 8        | BH-3315<br>BH-2954<br>BH-2942 | Bolt - Motor Mounting<br>1 Speed - 1/4, 1/2 and 1 HP<br>1 Speed - 2-1/2 HP<br>2 Speed | 4          |

\* Furnished only as part of motor assembly.

### NOTES

---

---

---

---

---

---

---

---

---

---

---

---

---

---

---

---

---

---

---

---

---

---

---

---

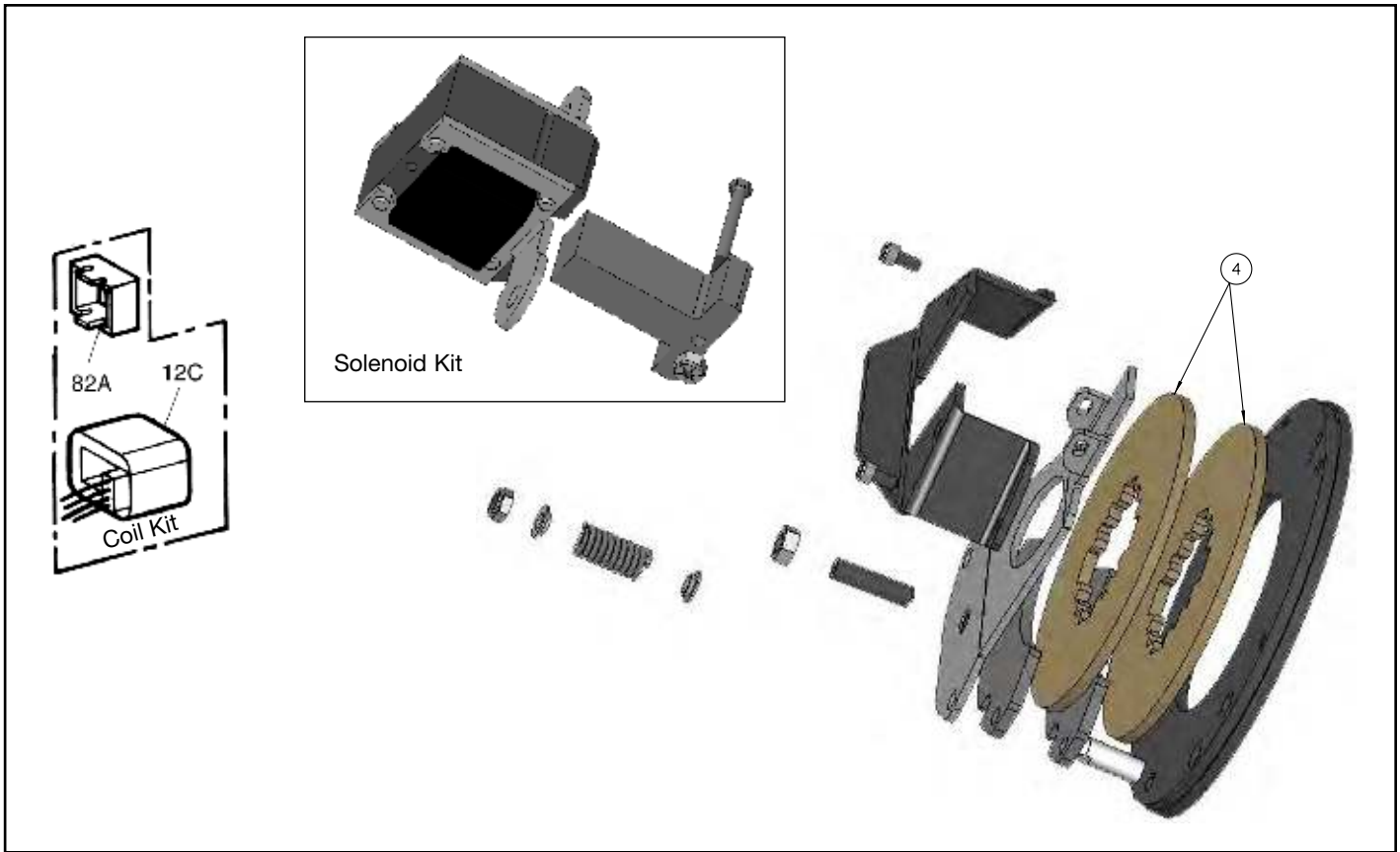

Figure 9-15. HOIST MOTOR BRAKE

| Part No.                      | Motor HP       | Motor RPM | Voltage                      | Coil Kit                      | Brake Torque ft. - lbs. |
|-------------------------------|----------------|-----------|------------------------------|-------------------------------|-------------------------|
| BH-4040<br>BH-4041<br>BH-4042 | 1/4            | 1800      | 115/230 1Ø<br>230/460<br>575 | BH-4097<br>BH-4095<br>BH-4096 | 1-1/2                   |
| BH-4043<br>BH-4044<br>BH-4045 | 1/2            | 1800      | 115/230 1Ø<br>230/460<br>575 | BH-5000<br>BH-4098<br>BH-4099 | 3                       |
| BH-4046<br>BH-4047<br>BH-4048 | 1              | 1800      | 115/230 1Ø<br>230/460<br>575 | BH-5003<br>BH-5001<br>BH-5002 | 6                       |
| BH-4043<br>BH-4044<br>BH-4045 | 1              | 3600      | 115/230 1Ø<br>230/460<br>575 | BH-5000<br>BH-4098<br>BH-4099 | 3                       |
| BH-4046<br>BH-4047<br>BH-4048 | 2-1/4<br>2-1/2 | 3600      | 115/230 1Ø<br>230/460<br>575 | BH-5003<br>BH-5001<br>BH-5002 | 6                       |

| Ref. No. | Part No. | Description   |
|----------|----------|---|
| 4        | BH-5004  | Solenoid Kit  |
|          | BH-5005  | Friction Disc (1½ & 3 ft. lbs. use 1 disc - 6 ft. lbs. use 2 discs) |
|          | BH-5006  | Brake Hub (not shown)   |
|          | BH-5007  | Brake Cover - Yellow Power Coat (not shown)                         |
|          | BH-5008  | Brake Cover - Primer (not shown)                                    |

## Recommended Spare Parts for Your Budgit Hoists

Certain parts of your hoist will, in time, require replacement under normal wear conditions. It is suggested that the following parts be purchased for your hoist as spares for future use.

|                                      |                       |
|--------------------------------------|-----------------------|
| Set of Gaskets                       | Contactactor          |
| Set of Bearings                      | Transformer Fuse      |
| Set of Oil Seals                     | Limit Lever           |
| Lower Block Assembly                 | Limit Switch Assembly |
| Load Chain                           |                       |
| Set of Brake Discs for Load Brake    |                       |
| Set of Brake Discs for Motor Brake   |                       |
| Push Button Station & Cable Assembly |                       |
| Transformer                          |                       |

**Note: When ordering parts always furnish Model and Catalog Number of Hoist and lift of hoist on which the parts are to be used.**

Parts for your hoist are available from your local authorized **Budgit Hoists** repair station. For the location of your nearest repair station, write:

**Phone: (800) 888-0985 • Fax: (800) 689-5644**

# WARRANTY

## WARRANTY AND LIMITATION OF REMEDY AND LIABILITY

A. Seller warrants that its products and parts, when shipped, and its work (including installation, construction and start-up), when performed, will meet applicable specifications, will be of good quality and will be free from defects in material and workmanship. All claims for defective products or parts under this warranty must be made in writing immediately upon discovery and in any event, within one (1) year from shipment of the applicable item unless Seller specifically assumes installation, construction or start-up responsibility. All claims for defective products or parts when Seller specifically assumes installation, construction or start-up responsibility and all claims for defective work must be made in writing immediately upon discovery and in any event, within one (1) year from completion of the applicable work by Seller, provided; however, all claims for defective products and parts must be made in writing no later than eighteen (18) months after shipment. Defective items must be held for Seller's inspection and returned to the original f.o.b. point upon request. **THE FOREGOING IS EXPRESSLY IN LIEU OF ALL OTHER WARRANTIES WHATSOEVER, EXPRESS, IMPLIED AND STATUTORY, INCLUDING, WITHOUT LIMITATION, THE IMPLIED WARRANTIES OF MERCHANTABILITY AND FITNESS.**

B. Upon Buyer's submission of a claim as provided above and its substantiation, Seller shall at its option either (i) repair or replace its

product, part or work at either the original f.o.b. point of delivery or at Seller's authorized service station nearest Buyer or (ii) refund an equitable portion of the purchase price.

C. This warranty is contingent upon Buyer's proper maintenance and care of Seller's products, and does not extend to normal wear and tear. Seller reserves the right to void warranty in event of Buyer's use of inappropriate materials in the course of repair or maintenance, or if Seller's products have been dismantled prior to submission to Seller for warranty inspection.

D. The foregoing is Seller's only obligation and Buyer's exclusive remedy for breach of warranty and is Buyer's exclusive remedy hereunder by way of breach of contract, tort, strict liability or otherwise. In no event shall Buyer be entitled to or Seller liable for incidental or consequential damages. Any action for breach of this warranty must be commenced within one (1) year after the cause of action has accrued.

**BUDGIT®**  
**Hoists**

Authorized Sales & Service - McLaughlin Hoist & Crane - For Parts or Service Call (636) 343-9700