

CHESTER HOIST

AIR LOW HEADROOM CHAIN HOISTS

AL-680

SECTION A

OPERATING and MAINTENANCE INSTRUCTIONS FOR AL SERIES HOISTS

Users should refer to the ANSI B30.16 American National Standard and ASME HST-5M Performance Standard for Air Chain Hoists for specific requirements regarding safety practices for the installation, maintenance, and operation of this equipment.

Your Order No. _____

Hoist Serial No. _____

Model No. _____

When ordering parts, please use hoist serial number

CHESTER HOIST

Chester Hoist · P.O. Box 449 · 7573 St. Rt. 45 · Lisbon, Ohio

44432 Phone (330) 424-7248 · Fax (330) 424-3126

Authorized Sales & Service - McLaughlin Hoist & Crane - For Parts or Service Call (636) 343-9700

TABLE OF CONTENTS

- I. Safety Precautions..... 3
- II. Installation Instructions..... 3
 - General Instructions 3
 - Load Hook Direction 3
 - Limit Valve Operation 4
 - Brake Operation..... 4
 - Installation on Beam 4
 - Hoist Speed Adjustment 4
 - Air Supply 4
- III. Operation..... 5
 - Operating Personnel..... 5
 - Good Operating Practices 5
 - Handling the Load..... 5
- IV. Inspection..... 6
 - Daily Inspection 6
 - Quarterly Inspection..... 6
 - Annual Inspection. 7
- V. Maintenance..... 7
 - Maintenance Procedure..... 7
 - Adjustments and Repairs 7
 - Lubrication 8
 - Chain Inspection, Replacement, and Maintenance 8
 - Load Sheave Timing..... 8
 - Brake Maintenance, Lubrication, and Repairs..... 8-9
- VI. Functional Testing 9
- VII. Illustrated Parts List 13
 - Chain Container Installation Notes..... 14
 - Warranty Information 19

WARNINGS, CAUTIONS and NOTES are used throughout this manual to emphasize important and critical instructions. For this purpose WARNINGS, CAUTIONS, and NOTES are defined as follows:

WARNING: An instruction which if not properly followed could result in personal injury or death.

CAUTION: An instruction which if not properly followed could result in damage to equipment or property.

NOTE: An instruction which is important to highlight.

WARNING:

Failure to read and follow the instructions contained in this manual could result in unsafe hoisting practices which may lead to personal injury or property damage.

I - SAFETY PRECAUTIONS

This hoist is designed for safe operation within the limits of its rated capacity. There are safety features built into the hoist to protect the operator and others from injury due to failure of the hoist itself. However, listed below are safety pointers which must be followed in order to protect personnel and property.

1. Avoid side pull or end pull at all times.
2. Limit valves are emergency devices. Do not use limit valves to stop the hoist in normal operation. Do not leave the load block in contact with the limit valve at end of operation.
3. Do not operate the hoist with twisted, kinked, or damaged chain.
4. Do not operate the hoist with a chain that is not properly seated in all pockets.
5. Do not operate a damaged or malfunctioning hoist until necessary adjustments or repairs have been made.
6. Do not use the hoist to lift, support, or otherwise transport people or carry loads over people.
7. Make sure all supporting structures are strong enough to hold your intended load.
8. Do not lift more than the rated capacity of the hoist.
9. Do not use the chain as a substitute for slings.
10. Allow only qualified personnel to operate the hoist.
11. Do not leave a load suspended in the air unattended.
12. Avoid jogging the controls or quick reversals of load.
13. Always disconnect the hoist from the air supply before making air connections or repairs. The main valve to the hoist should be locked out during repairs.
14. Do not use pendant air lines to move either the hoist or load along the rail.
15. When replacement parts are required, use only parts supplied by the manufacturer.

II - INSTALLATION INSTRUCTIONS

1. GENERAL INSTRUCTIONS

- a. The air supply should be within plus or minus 10% of the pressure specified on the hoist nameplate. (Normally 90 PSI)
- b. Supporting structures including trolleys, monorails, etc., should have a load rating at least equal to the hoist plus the weight of the hoist.
- c. Check the lubrication level in the gear case and trolley gear case (if supplied with the hoist).
- d. Check chain for damage and improper seating in load or idler sheaves.

2. LOAD HOOK DIRECTION

When installing your hoist, connect the control pendant to the manifold. Push the "UP" lever and observe the direction of the load block. If the load block rises, the connection is correct and does not need to be changed. If the load block lowers, release the button immediately. To correct the load block direction, reverse the two control lines from the pendant to the manifold. **DO NOT CHANGE CONNECTIONS AT ANY OTHER LOCATION.**

3. LIMIT VALVE OPERATION

Before placing the hoist in operation, check for proper upper limit valve operation. Push the "UP" button and, while the hoist is moving upward, raise the upper limit valve lever. The hook should stop immediately. **REPEAT THIS PROCEDURE FOR THE LOWER LIMIT VALVE. DO NOT OPERATE THE HOIST IF EITHER OF THE LIMIT VALVES ARE NOT OPERATING PROPERLY.**

4. BRAKE OPERATION

NOTE: Run in hoist with a light load a few times before lifting the rated load. After lifting a light load a few times, test the hoist per paragraph VI. Check for load block drift with the maximum rated capacity load on the hook. If the hook does not stop within one to two inches when the push button is released, it may be necessary to service the brake. See paragraph V.8.

5. INSTALLATION ON BEAM (See page 11)

6. HOIST SPEED ADJUSTMENT

After installing the hoist, but prior to placing the unit into service, the hoist speed must be set to insure safe operation. The hoist speed has been set at the factory but may need to be adjusted to compensate for the job site air supply. To adjust the hoist speed:

- a. With **NO** load on the hoist, run the hoist upward and time the load block movement. The unloaded block should move no faster than 25% above the rated speed for the unit. If the hoist is operating faster than recommended, it may cause severe damage to the hoist. To adjust the hoist lifting speed, loosen the lock nut on the adjusting bolt on the end of the remote control valve (RCV) towards the hoist body. Adjusting this bolt into the valve will slow down the lift speed. Adjusting the bolt out of the valve will speed the hoist up.
- b. With **RATED** load on the hoist, run the hoist down and time the load block movement. The loaded block should move no faster than 25% above the rated speed for the unit. If the hoist is operating faster than recommended, it may cause severe damage to the hoist. To adjust the hoist lowering speed, loosen the lock nut on the adjusting bolt on the end of the remote control valve (RCV) away from the hoist body. Adjusting this bolt into the valve will slow down the lowering speed. Adjusting the bolt out of the valve will speed the hoist up.

7. AIR SUPPLY

- a. The air supply pressure should be within 10% of the rated pressure. (Normally 90 PSI)
- b. Supply lines should be of adequate size to provide an adequate amount of air flow to the hoist.
- c. Never operate the hoist without an air line filter to remove moisture and contaminants.

- d. Never operate the hoist without an air line oiler to supply oil laden air to the hoist. Lubrication supplied by this oiler is critical to the operation of the hoist motor, brake, and air controls.

WARNING: Failure to provide clean, dry, and oil laden air to the hoist will damage the hoist and create excessive maintenance.

III - OPERATION

1. OPERATING PERSONNEL

It is recommended that hoist operation be limited to the following personnel:

- a. Appointed operators who have passed a practical operating examination.
- b. Maintenance and test personnel when it is necessary in the performance of their duties.
- c. Inspectors.

2. GOOD OPERATING PRACTICES

- a. The operator should not engage in any practice which will divert his or her attention while operating the hoist.
- b. When an "out-of-order" sign is on the starting controls, the operator should not power the unit or start operations until the sign has been removed by a designated person.
- c. Before starting the hoist, the operator should be certain that all personnel are clear.
- d. The operator should familiarize himself/herself with the equipment and its proper care. If adjustments or repairs are necessary or any damage is known, or suspected, he or she should report promptly report the problem to the appointed person. He or she should also notify the next operator of the damage upon changing shifts.
- e. All controls, such as push button stations, brakes, and limit switch(es) should be tested by the operator before beginning a shift. If any controls do not operate properly, they should be adjusted or repaired before operations are started.

3. HANDLING THE LOAD

- a. Size of the Load
Do not load the hoist beyond the rated capacity.
- b. Attaching the Load
 - (1) The hoist chain should not be wrapped around the load.
 - (2) The load should be attached to the hook by means of slings or other approved devices.
 - (3) The slings or other approved devices shall be seated properly in the saddle of the hook before operation.
- c. Moving the Load
 - (1) The load should not be moved or lifted more than a few inches until it is well-balanced on a sling or lifting device.

- (2) Care should be taken in hoisting to be certain that:
 - (a) Hoist chain is not kinked or twisted.
 - (b) Load does not contact any obstructions.
 - (c) Multiple part chains are not twisted about each other.
- (3) No hoist should be operated until the hoist unit is centered over the load.
- (4) The operator should test the brake each time a load approaching the rated capacity is handled by raising the load just enough to clear the floor or supports and checking for brake action. The lift should be continued after the operator is assured the brake is operating properly.
- (5) The operator should inch the hoist into engagement with a load and avoid unnecessary stops and starts.

IV - INSPECTION

Inspection procedures are divided into three general classifications based upon the intervals at which inspection should be performed. Deficiencies should be carefully examined and corrected. The intervals between inspections will vary due to operating conditions and amount of use. The following inspection intervals are based on intermittent use under normal environmental conditions. If the hoist is used more than intermittently or under adverse environmental conditions, it should be inspected more frequently.

1. DAILY INSPECTION

Inspect the following items daily before operating the hoist:

- a. Check all controls and operating mechanisms for proper operation.
- b. Check limit valves and brake for proper operation.
- c. Check hooks for deformations, chemical damage, or cracks. Replace any hook that is showing any of these signs.

NOTE: Any hook that is twisted or has throat opening in excess of normal, indicates abuse or overloading of the hoist. When a hook is found to be in this condition, other load bearing components of the hoist should be inspected for damage.

- d. Check chain for wear, twist, or distortion.
- e. Check for damaged or improperly working safety latch.

2. QUARTERLY INSPECTION

Inspect the following items at 90-day intervals:

- a. Check all items under daily inspection.
- b. Check for loose bolts, screws, and nuts.
- c. Inspect load chain wheels for cracks and excessive wear.
- d. Inspect for worn, corroded, cracked, or distorted parts.
- e. Check for proper operation of brake. See paragraph II.4.
- f. Inspect for excessive wear of chain. See paragraph V.5.
- g. Check air lines and components for any deterioration of controls, limit valves, and push button pendant.
- h. Check chain container if available. (See page 14)

3. ANNUAL INSPECTION

Inspect the following items annually:

- a. Check all items under daily and 90-day interval inspection.
- b. Check hooks for cracks by means of a magnetic particle test or other suitable crack detecting test.
- c. Inspect supporting structures and trolleys (if used) for continued ability to support the imposed loads.
- d. Check the brake for proper operation. See paragraph V.8.

NOTE: A hoist which has been idle for a period of one month or more, but less than six months, should be given an inspection of the items listed under paragraphs IV.1 and IV.2. A hoist which has been idle for a period of six months or more should be given a complete inspection.

V - MAINTENANCE

A preventive maintenance program based on the following should be established for the hoist. It is recommended that detailed records be kept and made available to appointed personnel.

NOTE: Only parts obtained from Chester Hoist should be used in maintenance of the hoist.

1. MAINTENANCE PROCEDURE

Before adjustments or repairs are started on the hoist, the following precautions should be taken:

- a. The main valve on the line feeding the hoist should be locked in the closed position.
- b. Warning or "out-of-order" signs should be placed on the hoist. These signs should be placed and removed only by designated personnel.

2. ADJUSTMENTS AND REPAIRS

Any unsafe conditions disclosed by inspection should be corrected before operation of the hoist is resumed. Adjustments and repairs should be accomplished only by qualified personnel.

a. Adjustments

Adjustments should be made to assure correct functioning of components after replacements or when malfunctions are detected.

(1) Brake Adjustment

The hoist brake is nonadjustable. See section V.8 for more information.

(2) Air line oiler adjustment

The air line oiler should be adjusted to provide 14-16 drops per minute to the hoist.

(3) Hoist speed adjustment

See section II.6

b. Repairs or Replacements

Repairs or replacements should be provided promptly as needed for correct operation. The following are examples:

- (1) Replace all critical parts which are cracked, broken, bent, or excessively worn.
- (2) Replace damaged or worn air lines.
- (3) Keep push button control pendants clean and function labels legible.
- (4) Replace hooks showing defects described in paragraph IV.1.c.
- (5) Replace chain showing defects described in paragraph V.5.
- (6) Replace missing or illegible warning labels.
- (7) Replace brake linings when worn excessively.

3. LUBRICATION

Lubricate the hoist according to Table 1.

4. CHAIN MAINTENANCE

- a. Load chain must be kept well lubricated and free of foreign matter to insure proper service.
- b. See Table 1 for specific lubricants.

5. CHAIN INSPECTION

- a. Daily, the chain should be checked for wear, twists, broken, or damaged links.
- b. Chain should be clean and free of foreign material or rust.
- c. Chain should be properly lubricated.

6. CHAIN REPLACEMENT

- a. When replacing load chain, the two chains must be exactly the same length.
- b. The starting chain link on each chain must be simultaneously fed into the two lifting load sheaves.
- c. The starting links must pass over the top of the load sheave in a horizontal position to permit end attachment without twisting the chain.
- d. The second link of chain will be a standing link of chain; this link should have the weld furthest away from the center of the load sheave.
- e. See Figure 1 for chain reeving.
- f. Use only chain supplied by Chester Hoist Inc.
- g. See page 14 for instructions on loading chain into a chain container if applicable.

7. LOAD SHEAVE TIMING

- a. Refer to Figure 2.
- b. To enable the two independent chains to lift the bottom block evenly, the large gears and load sheaves must first be timed as illustrated. Then both gears must be timed simultaneously with the shaft pinions. This timing procedure is only necessary when the gears have been disengaged during disassembly. Fig. 2.

8. BRAKE MAINTENANCE

- a. This air hoist incorporates a spring engaged brake for fail safe operation. When air to the control valve is lost or air is exhausted,

springs engage the brake. The brake has a manual release to disengage the brake for maintenance.

WARNING: Never manually disengage the hoist brake with a load supported or the load block in a raised position. Never operate the air motor with the brake manually disengaged.

- b. **Lubrication:** Lubrication is critical to the operation of this brake. The brake should not be operated with the air line oiler disconnected. All bearings are sealed and permanently lubricated.
- c. **Brake Repairs:** This brake is nonadjustable and requires no regular maintenance. If the brake fails to operate properly, refer to the manufacturer's maintenance instructions which are included in the parts manual for this unit.

VI - FUNCTION TESTING

After load sustaining parts have been altered, replaced, or repaired, the hoist should be load tested. The hoist should be tested using 100% of rated capacity.

TABLE 1. LUBRICATION

PART TO BE LUBRICATED	LUBRICANT	INSTRUCTIONS	FREQUENCY
Transmission	Mobil Glygoyle 460 Synthetic Lubricant or Mobilgear #634 (See Parts Manual for Proper Lubricant)	Drain from drain plug in bottom of housing. *Fill to level plug on side of housing.	After initial 50 hours of operation, then every 3 months or 500 hours of operation.
Motorized Trolley Gear Box	Mobil Glygoyle 460 Synthetic Lubricant	Drain from drain plug in bottom of housing. *Fill to level plug on side of housing.	
Load Block	NLGI No. 2 Grease	Lubrication is required only when sheave pin contains grease fittings.	30 days
Load Chain	Intermediate oils preferably with E.P. Additives.	Immerse in oil or swab with oil soaked rag. Wipe off excess oil. Maintain chain rust-free.	Daily
	Bonded Lubricants such as Dow Molykote M-88.	Use in place of oil, if oil residue is objectionable.	Daily
**Trolley Wheels	NLGI No. 2 Grease	Wheels will have grease fittings. (See note below)	After prolonged use or reassembly
Spur Gears	NLGI No. 2 Grease	Brush on exposed gears	Weekly

* See Parts Manual for plug locations.

** Not required on units equipped with sealed ball bearings. (Wheels will not have grease fittings)

CHAIN REEVING

Fig.1

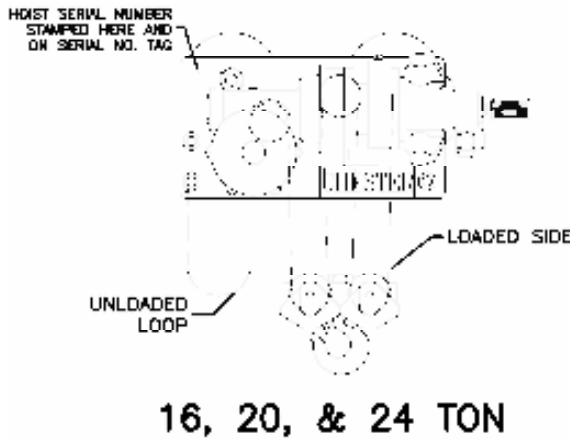
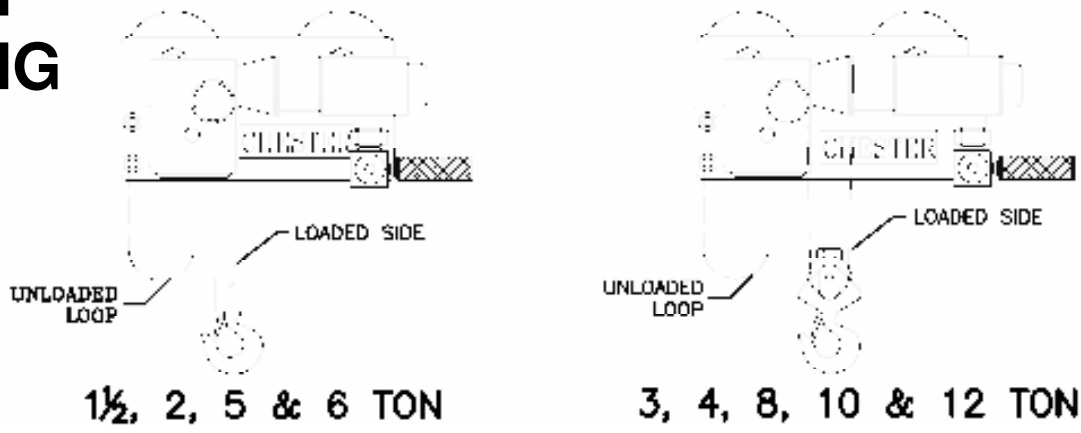

NOTE: LOOKING AT HOIST MOTOR SIDE

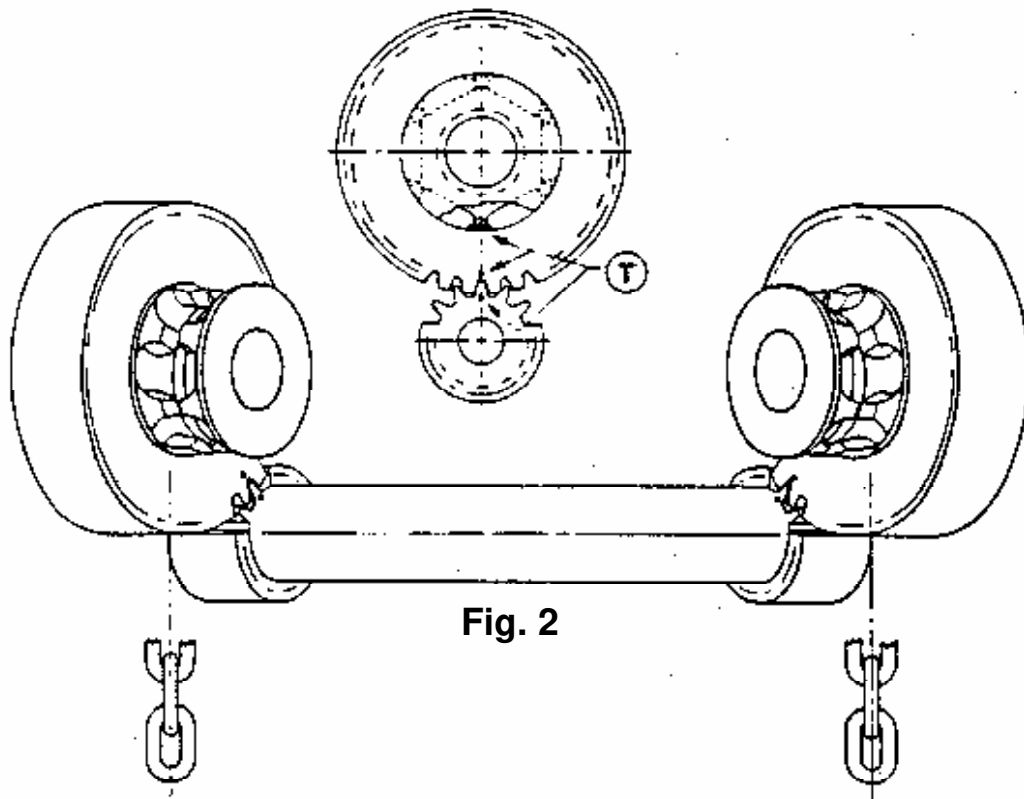
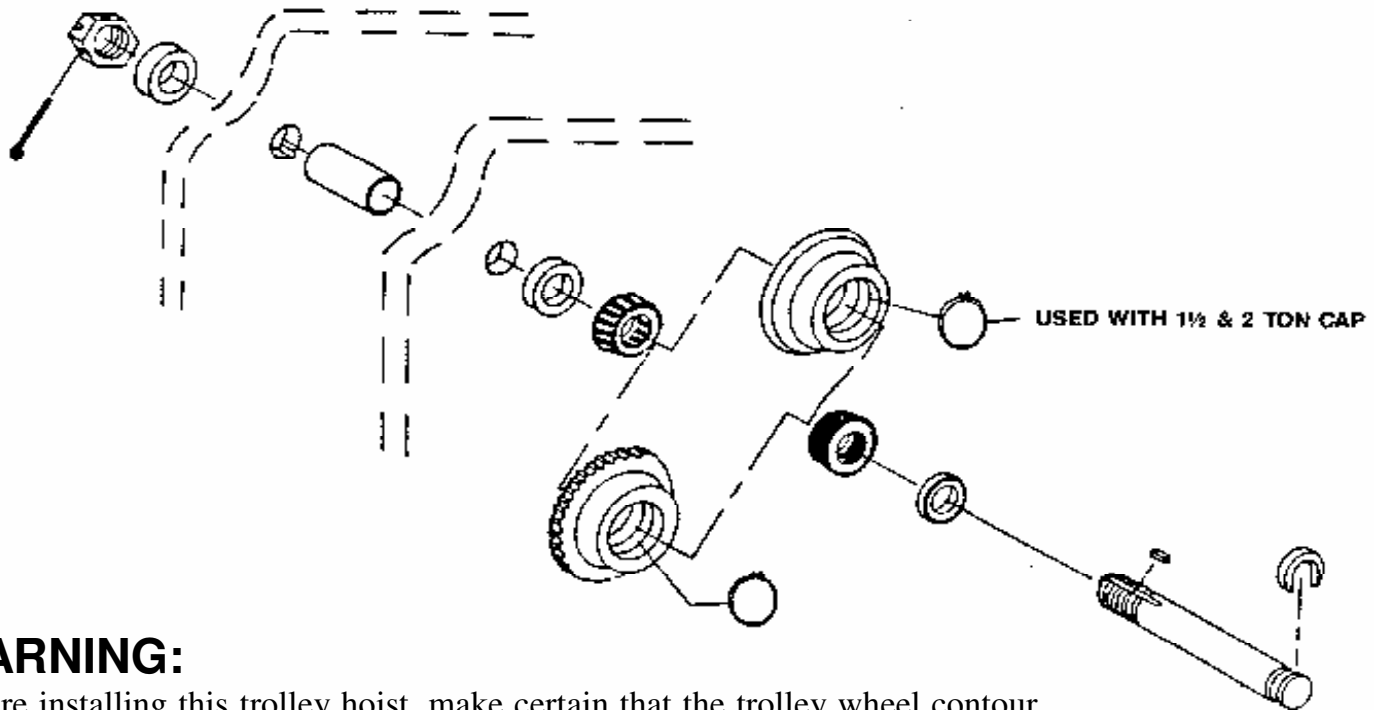

Fig. 2

T Indicates three timing marks in alignment



WARNING:

Before installing this trolley hoist, make certain that the trolley wheel contour is correct for the type of beam the unit will operate on and that the trolley wheel spacing is correct for the beam flange width. Flat flange beams should have flat tread or universal tread wheels and tapered flange beams should have tapered or universal tread wheels.

INSTALLATION

The hoisting unit is custom sized at the factory to fit on a specific beam size. Most units are slipped over the end of the supporting rail or beam; however, removable wheels* are provided which enables the unit to be fitted on a beam with obstructed ends.

See parts breakdown above the additional information regarding disassembly.

The distance between trolley wheel flanges (measured at the tread diameter) should be 1/8" to 3/16" greater than the beam flange width for proper running clearance. This clearance should be checked before operating the hoist under load. The hoist should be traversed the entire length of the beam to check for beam interference points, proper side clearance, and effectiveness of the beam stops. If everything is satisfactory, the procedure should be repeated with a capacity load as a functional installation test.

WARNING:

Always make sure all end stops are securely in place before operating a hoist on a runway beam to prevent the hoist from falling from the open beam end.

**Feature not available on units operating on patented monorail tracks.*

TABLE 2. TROUBLESHOOTING

TROUBLE	CAUSE	REMEDY
Hook Fails to Stop at End of Travel	<ol style="list-style-type: none"> 1. Improperly operating brake. 2. Worn brake linings. 3. Air controls not functioning properly. 	<ol style="list-style-type: none"> 1. See Section V.8. 2. Replace when worn excessively. 3. Check air controls. See schematic supplied.
Hoist Does Not Respond to Push Button	<ol style="list-style-type: none"> 1. No air. 2. Inadequate air. 3. Brake does not release. 4. Improper connections in hoist or push button station. 5. Faulty control valves. 	<ol style="list-style-type: none"> 1. Check air supply. 2. Check air supply. 3. Check brake operation. Section V.8. 4. Check all connections. See control schematic. 5. Check all valves for proper operation. See control schematic.
Hook Does Not Stop Promptly	<ol style="list-style-type: none"> 1. Hoist overloaded. 2. Brake not holding. 	<ol style="list-style-type: none"> 1. Reduce load to within rated capacity of hoist. 2. Check brake operation. See Section V.8.
Hook Moves in Wrong Direction	<ol style="list-style-type: none"> 1. Improper connections. 	<ol style="list-style-type: none"> 1. Reverse air lines on pendant control. See control schematic.
Hook Raises But Will Not Lower	<ol style="list-style-type: none"> 1. "Down" circuit open. 2. Broken or blocked air line. 3. Faulty remote control valve. 	<ol style="list-style-type: none"> 1. Check all connections and down limit valve operation. 2. Check all air lines. 3. Check operation of remote control valve.
Hook Lowers But Will Not Raise	<ol style="list-style-type: none"> 1. Hoist overloaded. 2. Low air supply. 3. "UP" circuit open. 4. Broken or blocked air line. 5. Faulty remote control valve. 	<ol style="list-style-type: none"> 1. Reduce load to within rated capacity. 2. Check air supply. 3. Check all connections and up limit valve operation. 4. Check all air lines. 5. Check operation of remote control valve.
Lack of Proper Lifting Speed	<ol style="list-style-type: none"> 1. Hoist overloaded. 2. Brake not releasing fully. 3. Low air supply. 4. Improperly adjusted RCV. 	<ol style="list-style-type: none"> 1. Reduce load to within capacity of hoist. 2. Check brake operation. See Section V.8. 3. Check air supply. 4. See Section II.6.

VII - ILLUSTRATED PARTS LIST

GENERAL

The illustrated parts lists that follow are designed to help you identify replacements parts for your Chester hoist. In addition to exploded illustrations which cover a large part of your hoist, some manufacturers' sheets are included for such items as motors, brakes, push buttons, and other items. If assistance is required, please contact your Chester representative.

HOW TO USE THE PARTS LISTS

To identify a part from your hoist, locate the illustration for the affected section of the hoist. Study the illustration and locate the part you wish to find. An arrow will be pointing to the part from a number. This figure number will be found in the accompanying parts list with the part name, part number, and quantity required.

When ordering parts, please send the following information:

1. Serial Number of your hoist (see Figure 1 for location).
2. Title of illustration (for example, 3 – 4 Ton bottom block assembly).
3. Figure Number, Part Name, Quantity Required, and Part Number.
4. Any additional information required by notes at the bottom of parts lists.

MAINTENANCE AND OPERATING PROCEDURES: (USER'S RESPONSIBILITY)

All equipment should be inspected, tested, operated, and maintained according to the manufacturer's recommendations and the applicable sections of ASME/ANSI B30.16, B30.11, and B30.17. Consideration should also be given to pertinent federal, state, and local regulations.

POST INSTALLATION INSPECTION CHECK LIST

After installation, the following items should be checked:

- (a) hoist hook motion and trolley motion for agreement with control indication direction and prompt return of actuators to the OFF position.
- (b) hoist load chain free from twists, damage, and improper seating in pockets.
- (c) lift and travel limiting devices for proper operation.
- (d) braking system for proper operation.
- (e) load chain for proper lubrication.
- (f) hoist and trolley for proper lubrication.

CHAIN CONTAINER INSTALLATION NOTES:

The chain container for this hoist has been shipped loose. Follow these instructions to install the container and to load the chain into the container.

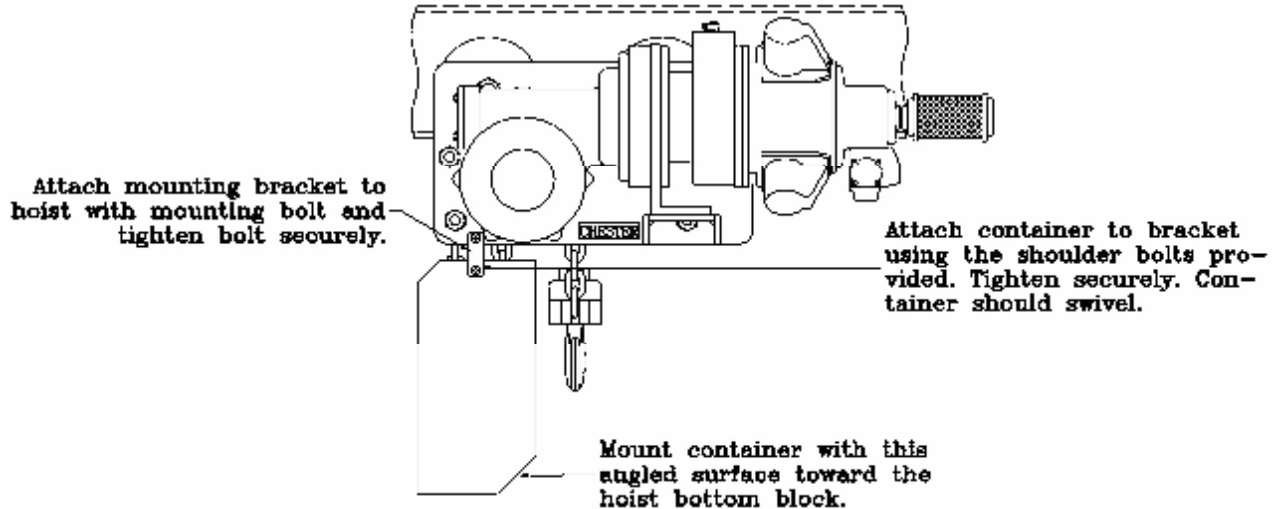

CHAIN LOADING NOTE:

Lower the load block as far as possible. After installing the chain container, run the load block up allowing the hoist mechanism to fill the container. Verify the chain is loading properly into the container.

WARNING!!

Never load the chain into the container by hand!!! Hand loading will cause the chain to tangle which will jam and damage the hoist.

INSPECTION NOTE:

The mounting bolts for the container should be checked each time the hoist is inspected to ensure they remain tight. The mounting holes on the container and bracket should be checked each time the hoist is inspected to ensure they are not elongating and weakening the container or bracket.

SERVICE NOTES

SERVICE NOTES

SERVICE NOTES

SERVICE NOTES

WARRANTY

All goods sold by SELLER hereunder are sold with only the following warranty: SELLER warrants that the goods shall be free from defects in material and workmanship under normal use and service. SELLER'S obligation under this warranty is limited to reworking or replacing at its option, any goods, which, within the time stated herein, shall be returned to it at its place of business at the address set forth herein with two-way packaging and shipping costs prepaid, and which upon examination and determination by SELLER, shall be found to have been thus defective. The rework, repair or replacement of defective goods under this warranty will be made without charge for material or labor. This warranty shall remain in force and be valid on goods manufactured by SELLER, or manufactured by others to SELLER'S detailed design for 12 months from the date of shipment by SELLER to BUYER. THE WARRANTY PROVIDED IN THIS ARTICLE 1, THE OBLIGATIONS AND LIABILITIES OF SELLER HEREUNDER AND THE RIGHTS AND REMEDIES OF BUYER HEREUNDER ARE EXCLUSIVE AND IN SUBSTITUTION FOR, AND BUYER HEREBY WAIVES, ALL OTHER WARRANTIES, GUARANTEES, OBLIGATIONS, LIABILITIES, RIGHTS AND REMEDIES, EXPRESSED OR IMPLIED, ARISING BY LAW OR OTHERWISE, INCLUDING BUT NOT LIMITED TO THE IMPLIED WARRANTY OF MERCHANTABILITY, ANY IMPLIED WARRANTY ARISING FROM COURSE OR PERFORMANCE, COURSE OF DEALING OR USAGE OF TRADE, ANY IMPLIED WARRANTY OF FITNESS AND ANY OBLIGATION OR LIABILITY OF SELLER ARISING FROM TORT, OF FOR LOSS OF USE, REVENUE OR PROFIT, OR FOR INCIDENTAL OR CONSEQUENTIAL DAMAGES. SELLER SHALL NOT BE LIABLE UNDER ANY CIRCUMSTANCES FOR MORE THAN THE REPLACEMENT

OR REFUND OF THE PURCHASE PRICE ON DEFECTIVE GOODS. Goods which are allegedly defective may not be returned to SELLER without prior written approval of SELLER. SELLER, at its option, may first request samples for inspection purposes. The provisions of this warranty shall not apply to, nor is any other warranty given on, goods which have not been used or maintained in accordance with SELLER'S Instructions or which have been subject to misuse, negligence or accident or which have been repaired, altered or modified in any way by anyone other than the SELLER. SELLER makes no warranty, expressed or implied (including without limiting the generality of the foregoing, any warranties of merchantability or fitness) with respect to any (accessory) goods not manufactured by SELLER. With respect to any such goods sold by SELLER to BUYER hereunder, including purchased goods incorporated in goods manufactured by SELLER, BUYER agrees to look solely to the manufacturer of such goods for any warranty. BUYER waives all claims other than claims based on SELLER'S expressed warranty or the added cost of replacement due to SELLER'S failure to deliver the goods purchased hereunder. Such waived claims shall include but not be limited to claims based on strict tort liability and other economic losses such as loss of profits, loss of business opportunity and loss of goodwill. Upon request, SELLER will furnish such technical advice or assistance as it has available in reference to the use of the goods; however, it is expressly understood that (i) SELLER assumes no obligation or liability for the advice or assistance given or results obtained, (ii) all such advice or assistance is given and accepted at BUYER'S risk, and (iii) such advice or assistance shall not increase or alter SELLER'S liability as herein defined and limited.

Authorization for return must be received from Chester Hoist before returning any equipment for inspection or warranty repair.

IMPORTANT NOTICE

Use of chain or replacement parts other than as supplied as original equipment on Chester hoists may lead to dangerous operation. Accordingly, Chester Hoist cannot be responsible in such cases and our warranty would be voided.

“CAUTION: Some of the hoists and trolleys manufactured by Chester Hoist can be adjusted to fit various sizes of runway beams. Others of our hoists and trolleys are built to fit a runway specified by our customers. Regardless, it is the customer's responsibility to apply such engineering calculations or tests as may be necessary to satisfy itself that the runway beam flanges are capable of carrying the loads expected to be handled.”

* ▲ WARNING
Overloading and improper use can result in injury.
<p>To avoid injury:</p> <ul style="list-style-type: none"> • Do not exceed working load limit, load rating or capacity. • Do not use to lift people or loads over people. • Use only alloy chain and attachments for overhead lifting. • Read and follow all instructions. • Do not use to lift, support or transport molten metal.

