

# **COFFING<sup>®</sup>** **HOISTS**

---

## **OPERATING & MAINTENANCE INSTRUCTIONS WITH PARTS LIST**

Publication Part No. EC3-680-2

### **EC - Electric Chain Hoist**

*For Model Nos:*

**EC-2032, EC-4016, EC-4024, EC-6010, EC-6016  
EC-8008, EC-8012, EC-10005, EC-10008**

*For Capacities:*

**2 - 5 Ton**

#### **IMPORTANT—CAUTION**

To safeguard against the possibility of personal injury or property damage, follow the recommendations and instructions of this manual. This manual contains important information for the correct installation, operation, and maintenance of this equipment. All persons involved in the installation, operation, and maintenance of this equipment should be thoroughly familiar with the contents of this manual. Keep this manual for reference and further use.

#### **▲ WARNING**

To prevent personal injury, do not use the equipment shown in this manual to lift, support, or otherwise transport people, or to suspend unattended loads over people.

**TABLE OF CONTENTS**

<b>SECTION I</b>	<b>INTRODUCTION</b>	
1-1	General Information .....	3
1-2	Safety Standards .....	
1-3	Hoist Construction and Features .....	
1-4	Basic Hoist Data .....	3
1-5	Application Information .....	3
1-6	Warranty .....	3
<b>SECTION II</b>	<b>INSTALLATION</b>	
2-1	Safety Notes .....	4
2-2	Hanging the Hoist .....	4
2-3	Power Supply Connection .....	4
2-4	Vent Plug .....	4
2-5	Chain Lubrication .....	4
2-6	Testing .....	4
2-7	Trolley Installation .....	4
2-8	Chain Container Installation .....	5
<b>SECTION III</b>	<b>OPERATION</b>	
3-1	General .....	6
3-2	Safety Notes .....	6
3-3	Handling the Load .....	6
3-4	Overload Limiting Protection .....	7
<b>SECTION IV</b>	<b>INSPECTION</b>	
4-1	General .....	7
4-2	Frequent Inspection .....	7
4-3	Periodic Inspection .....	7
4-4	Load Brake Function Check.....	9
4-5	Chain Inspection .....	9
4-6	Hook Throat Opening .....	10
<b>SECTION V</b>	<b>MAINTENANCE AND REPAIR</b>	
5-1	General .....	
5-2	Limit Switch Adjustment .....	
5-3	Motor Brake Adjustment .....	11
5-4	Top Suspension Removal and Replacement .....	11
5-5	Chain Replacement .....	11
5-6	Lubrication .....	13
5-7	Chain Stop Installation .....	15
<b>SECTION VI</b>	<b>TROUBLESHOOTING</b>	
6-1	General .....	15
<b>SECTION VII</b>	<b>WIRING</b>	
7-1	Voltage Conversion .....	17
7-2	Wiring Diagrams .....	17
<b>SECTION VIII</b>	<b>ILLUSTRATED PARTS LISTS</b>	
8-1	General .....	20
8-2	How to Use the Parts List .....	20
8-3	How to Order Replacement Parts .....	20
FIGURE 8-1	Basic Hoist .....	21
FIGURE 8-2	Suspension Assembly Kits .....	22
FIGURE 8-3	Motor Parts .....	23
FIGURE 8-4A	Controller Area (Single Speed) .....	24
FIGURE 8-4B	Controller Area (Two Speed) .....	25
FIGURE 8-5	Transmission .....	26
FIGURE 8-6A	Chaining Parts (Single Chain) .....	27
FIGURE 8-6B	Chaining Parts (Double Chain) .....	28
FIGURE 8-6C	Chaining Parts (Triple Chain) .....	29
FIGURE 8-7A	Standard Limit Switch Parts Used on Standard Lift Hoists .....	30
FIGURE 8-7B	Geared Limit Switch Parts Used on Long Lift Hoists .....	30
FIGURE 8-8	Motor Brake Parts .....	31
FIGURE 8-9	Counterweights .....	
FIGURE 8-10A	Pushbutton (Single Speed Hoists) .....	
FIGURE 8-10B	Pushbutton (Two Speed Hoists) .....	34

## INTRODUCTION

**1-1. General Information**

This manual provides information for the safe operation and maintenance of Coffing® EC-3 Series Hoists. All persons operating or maintaining these hoists should be familiar with the information contained herein. Adherence to the precautions, procedures, and maintenance practices described should ensure long reliable operation.

**1-2. Safety Standards**

All persons concerned with the installation, operation, inspection and maintenance of these hoists are urged to read American National Standard (ANSI) B30.16. That Standard contains valuable guidelines concerning practices designed to minimize hazards associated with the use of overhead hoisting equipment. ANSI B30.16 also contains detailed procedures for establishing hoist inspection and maintenance programs and can be of significant assistance in maintaining compliance with OSHA regulations.

**1-3. Hoist Construction and Features**

EC-3 Series Hoists incorporate the following features:

- a. Heat-treated alloy steel gearing.
- b. Overload limiting clutch.
- c. Completely independent mechanical and electrical brakes.
- d. Adjustable limit switches.
- e. Tough, nylon, weatherproof pushbutton stations.
- f. Steel strain cable inside pushbutton cord.
- g. Transformer isolated, low-voltage pushbutton controls.
- h. Quick voltage conversion on dual-voltage units.

**1-4. Basic Hoist Data**

The basic hoist models covered by this manual are listed in Table 1-1.

TABLE 1-1. BASIC HOIST DATA

Model No.	Rated Load (lb.)	Lift Speed at Rated Load (ft. per min.)	Motor HP
EC-2032	2000	32	2
EC-4016	4000	16	2
EC-4024	4000	24	3
EC-6010	6000	10	2
EC-6016	6000	16	3
EC-8008	8000	8	2
EC-8012	8000	12	3
EC-10005	10000	5	2
EC-10008	10000	8	3

**1-5. Application Information**

This hoist is intended for general industrial use in the lifting and transporting of freely suspended material loads within its rated load. Prior to installation and operation, the user should review his application for abnormal environmental or handling conditions and to observe the applicable recommendations as follows:

- a. **Adverse Environmental Conditions.** Do not use the hoist in areas containing flammable vapors, liquids, gases or any combustible dusts or fibers. Refer to Article 500 of *The National Electric Code*. Do not use this hoist in highly corrosive, abrasive or wet environments. Do not use this hoist in applications involving extended exposure to ambient temperatures below -40°F or above 130°F.
- b. **Lifting of Hazardous Loads.** This hoist is not recommended for use in lifting or transporting hazardous loads or materials which could cause wide-spread damage if dropped. The lifting of loads which could explode or create chemical or radioactive contamination if dropped requires fail-safe redundant supporting devices which are not incorporated into this hoist.
- c. **Lifting of Guided Loads.** This hoist is not recommended for use in the lifting of guided loads, including dumbwaiters and non-riding elevators. Such applications require additional protective devices which are not incorporated into this hoist. Refer to your state and local regulations governing the requirements for elevator and dumbwaiter installations.

**1-6. Warranty**

Every hoist is thoroughly inspected and tested prior to shipment from the factory. Should any problems develop, return the complete hoist prepaid to your nearest Coffing Authorized Warranty Repair Station. If inspection reveals that the problem is caused by defective workmanship or material, repairs will be made without charge and the hoist will be returned, transportation prepaid.

This warranty does not apply where: (1) deterioration is caused by normal wear, abuse, improper or inadequate power supply, eccentric or side loading, overloading, chemical or abrasive actions, improper maintenance or excessive heat; (2) problems resulted from repairs, modifications or alterations made by persons other than factory or Coffing Authorized Warranty Repair Station personnel; (3) the hoist has been abused or damaged as a result of an accident; (4) repair parts or accessories other than those supplied by Coffing Hoists are used on the hoist. Equipment and accessories not of the seller's manufacture are warranted only to the extent that they are warranted by the manufacturer. EXCEPT AS STATED HEREIN, COFFING HOISTS MAKES NO OTHER WARRANTIES, EXPRESS OR IMPLIED, INCLUDING WARRANTIES OF MERCHANTABILITY AND FITNESS FOR A PARTICULAR PURPOSE.

## SECTION II

### INSTALLATION

#### 2-1. Safety Notes

- a. Inspect the hoist for any evidence of shipping damage or loose parts.
- b. The supporting structure and load attaching devices should have a load rating at least equal to that of the hoist.
- c. This hoist is not suitable for use in uncovered outdoor locations or areas containing explosive dust, vapors or gases.
- d. The installation area must provide safe operating conditions for the operator, including sufficient room for the operator and other personnel to stand clear of the load at all times.
- e. In areas where slack chain hanging from the hoist may create a hazard, use a chain container (see Figure 2-2).

#### 2-2. Hanging the Hoist

Hook mounted hoists can be used with a variety of trolleys or stationary hangers. It is recommended that a hand-gear or motorized trolley be used when the pulling effort required to move the hoist exceeds 100 pounds or when the application requires frequent movement of the hoist.

- a. Make sure that the hook latch closes after hanging the hoist.
- b. See Figure 2-1 for instructions on adjusting lug-mounted plain trolleys.
- c. Refer to Coffing Motorized Trolley Operating and Maintenance Instructions manual for motorized trolley installation instructions.

#### 2-3. Power Supply Connection

- a. Disconnect power before making connections.
- b. Voltage supplied to the hoist should be within plus or minus 10% of the voltage specified for the hoist. Hoists are tagged at the factory with a tag indicating the voltage for which the hoist is wired. Standard single-speed, three-phase hoists are convertible from 460 volts to 230 volts. See the Wiring section (paragraph 7-1) for voltage conversion instructions.
- c. National Electrical Code (ANSI C1) and local electrical codes should be consulted and proper disconnects, branch circuit protectors, and wiring provided.
- d. Power cables furnished with the hoist have a green colored ground wire which must be securely connected to the electrical system ground.
- e. When installing a three-phase hoist, make only temporary connections at the power line. Push the "UP" button and observe the direction of the hook. If it raises, the phasing is correct and permanent connections may be made at the power line. If the load block lowers when the "UP" button is pushed, release the button immediately since the limit switches will not operate to protect the hoist from overtravel. Reverse the red and black wires at the power line connection to correct the hook direction.

#### CAUTION

**Do not change connections in the hoist or the pushbutton assembly.**

#### 2-4. Vent Plug

This hoist is shipped with a factory installed pressure relief fitting. This fitting needs no adjustments or maintenance before operating the hoist.

#### 2-5. Chain Lubrication

The hoist chain should be liberally oiled before placing the hoist into operation. For lubrication instructions, see paragraph 5-6.a.

#### 2-6. Testing

- a. Before placing the hoist into operation, check for proper limit switch operation. Push the "UP" button and verify that the hook block stops at least 2 inches from the bottom of the hoist. Run the hoist down to its lower limit. At least 12 links of chain should remain on the slack end. If either switch is not correct, adjust according to the procedure outlined in paragraph 5-2.

#### NOTE

The upper and lower limit switches are factory set to provide the maximum allowable hook travel. **This travel adjustment should not be increased.** However, the switches may be adjusted to stop the hook sooner at either end of its travel.

- b. Attach a light load to the hook and check the hoist for proper operation. The load should stop without noticeable drift when the pushbutton is released. Increase the load to near rated load. The hoist should still lift the load without hesitation and stop with no more than one-inch drift.

#### 2-7. Trolley Installation

Coffing® CT Series trolleys can be mounted on American Standard I Beams from 6 to 18 inches high (8-inch minimum on 4- or 5-ton models). Adjustment for different beam dimensions is accomplished with the proper placement of spacer washers as described below in paragraph 2-7.a.

- a. **"I"-Beam Adjustment.** Adjustment for "I" beam sizes and tolerances is accomplished by locating the spacer washers as shown in Figure 2-1. Normal placement of washers is given in Table 2-2. Refer to Table 2-1 for identification of part names and numbers.

BEAM MANUFACTURING TOLERANCES ALLOW WIDE VARIATIONS FROM HANDBOOK FLANGE WIDTHS, AND SLIGHT CHANGES TO RECOMMENDED WASHER DISTRIBUTION MAY BE NECESSARY TO SUIT SPECIFIC INSTALLATIONS.

The particular beam on which your hoist is to be installed should be measured and trolley spacer washers adjusted as required to achieve a clearance of  $3/32"$  to  $1/8"$ .

- b. **Periodic Inspection.** The trolley should be inspected periodically for evidence of excess wear or overload. Parts should be replaced as required.
- c. **Lubrication.** Trolley wheels are equipped with sealed, lifetime lubricated, precision ball bearings which should not require lubrication for the normal service of the trolley.

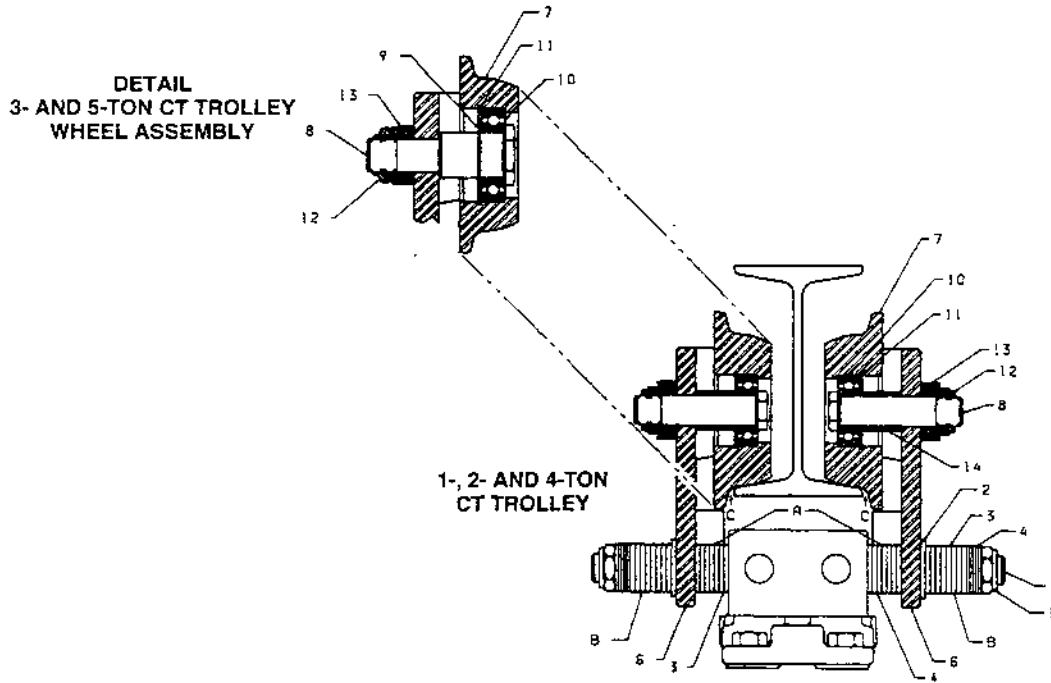


FIGURE 2-1. COFFING CT TROLLEY

TABLE 2-1. PARTS LIST FOR CT TROLLEY

INDEX NO.	PART NAME	PART NUMBERS	
		1, 2 & 4 TON	3 & 5 TON
1	Load Pin	103K1	103K1
2	Washer (1/8" Thick)	H-4211	H-4211
3	Washer (.135" Thick)	H-4209	H-4209
4	Washer (.075" Thick)	H-4210	H-4210
5	Nut	H-3945	H-3945
6	Side Plate	5KG4	5KG31
7	Wheel	45K7	45K2
8	Axle	102K1	102K2
9	Retaining Ring	Not Req.	H-5530
10	Bearing	500K4	500K5
11	Retaining Ring	H-5528	H-5529
12	Nut (Axle)	H-3945	H-3946
13	Washer	H-4211	H-4212
14	Spacer	200K1	Not Req.

TABLE 2-2. TROLLEY I-BEAM ADJUSTMENT DATA

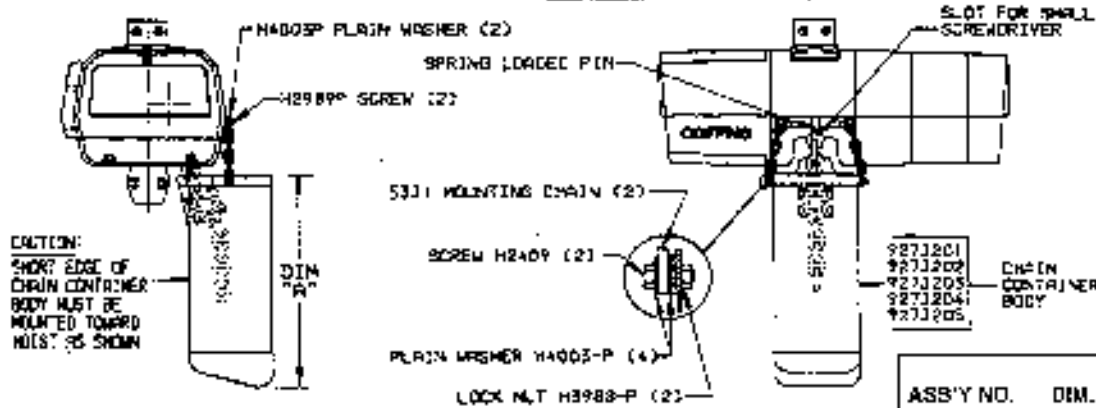
		"I" Beam Size					
		6"	8"	10"	12"	15"	18"
1, 2 And 3 Ton							
Washers Between Hoist & Trolley	Thick	0	3	1	4	7	6
	Thin	1	0	8	5	3	8
Washers Outside Trolley	Thick	7	4	6	3	0	1
	Thin	8	9	1	4	6	1
4 And 5 Ton							
Washers Between Hoist & Trolley	Thick		1	1	3	6	6
	Thin		0	4	3	1	4
Washers Outside Trolley	Thick		6	6	4	1	1
	Thin		5	1	2	4	1

**2-8. Chain Container Installation**

- a. Operate hoist in "down" direction until it is stopped by the limit switch. Disconnect the slack end of the chain from the hoist by using a small screwdriver to slide the spring-loaded pin to the left. At least 12 inches of chain should hang from the hoist. If less than 12 inches of slack chain is present, readjust lower limit switch using the procedures detailed in paragraph 5-2.b.
- b. Place the chain container in position with the spout toward the hoist. Place a hex head screw through each mounting chain

- with a flat washer between the chain and the head of the screw. Fasten each of the two mounting chains to the tapped holes on the side of the hoist, being sure the chains are not twisted.
- c. Be sure the end of the chain is started into the container. Run hoist up until the hook block is even with the bottom of the chain container.
- d. Reset upper limit switch at this position (see paragraph 5-2.a) to prevent the possibility of raising a load into the chain container.

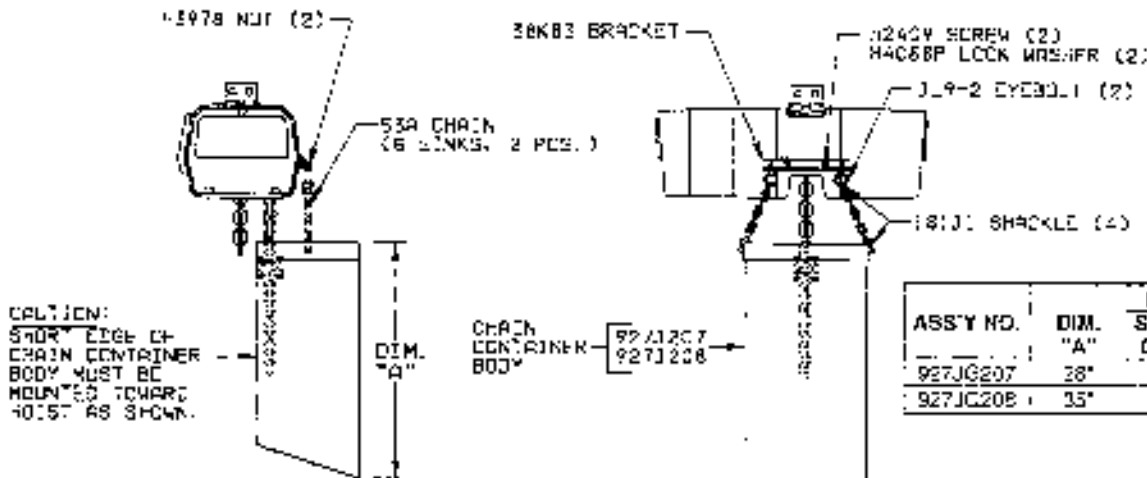
**For Models 927JG201-205**



ASS'Y NO.	DIM. "A"	MAX HOIST LIFT (FEET)		
		SINGLE CHAIN	DOUBLE CHAIN	TRIPLE CHAIN
927JG201	16"	13'	—	—
927JG202	20"	20'	15'	10'
927JG203	24"	50'	25'	16 1/2'
927JG204	33"	75'	37 1/2'	25'
927JG205	48 1/2"	100'	50'	33'

**WARNING**  
DO NOT ATTEMPT TO STORE MORE CHAIN IN CHAIN CONTAINER THAN THAT SPECIFIED IN TABLE OR SERIOUS DAMAGE TO HOIST MAY RESULT AND HAZARDOUS CONDITIONS MAY BE CREATED.

**For Models 927JG207 & 927JG208**



ASS'Y NO.	DIM. "A"	MAX HOIST LIFT (FEET)		
		SINGLE CHAIN	DOUBLE CHAIN	TRIPLE CHAIN
927JG207	28"	150'	75'	50'
927JG208	35"	200'	100'	66'

**FIGURE 2-2. CHAIN CONTAINER INSTALLATION**

**SECTION III  
OPERATION**

**3-1. General**

This section presents information concerning the proper operation of the Coffing® Electric Chain Hoist. It is not intended to serve as a handbook on rigging. Rigging, the process of moving heavy loads using mechanical devices, requires special knowledge and equipment. For information on the safe use of slings and similar rigging gear, users are urged to consult a textbook on rigging.

**3-2. Safety Notes**

- Inspect the hoist for any sign of loose, broken, or malfunctioning parts (see Section IV). Any malfunctioning hoist should be tagged as "out of order" and removed from service until the defect is corrected.
- Before starting the hoist, the operator should be certain that all personnel are clear.

- Do not lift more than the rated load of the hoist.
- Do not lift people or loads over people.
- Avoid joggling controls or quick reversals of suspended loads.
- Do not leave a suspended load unattended.
- The operator should have a clear view of the load anytime it is moving and should be sure that the load does not contact any obstructions.
- Read ANSI B30.16 Safety Standard for Overhead Hoists.

**3-3. Handling The Load**

- Align hoist directly over load. Avoid side pull.
- The hoist chain should not be wrapped around the load. Use proper slings.

- c. Be sure there are no twists in the load chain as it enters the hoist.

#### CAUTION

This condition should be constantly checked on double or triple chain hoists because it is possible for the load block to be "capsized" or flipped over one or more times, putting twist in the chain. The presence of twist may not be obvious when the hook block is in the lowered position but can cause serious chain binding when the hook block is in its fully raised position.

- d. Bring the hook into engagement with the load and make sure it is well seated before proceeding to lift the load. On multiple reeved hoists, be sure that the load is equalized on all supporting chains.
- e. Lift the load just clear of its supports and stop the hoist to check for proper brake operation.
- f. Avoid letting the hook or load swing excessively while moving a trolley suspended hoist.

### 3-4. Overload Limiting Protection

This hoist is equipped with a factory-calibrated overload limiting clutch, which will permit the lifting of loads within its load rating, but will prevent the lifting of damaging overloads while the hoist is being operated. If the load being lifted exceeds the lifting capability of the overload clutch, the hoist motor will continue to run, causing overheating of both the clutch and the motor. This condition should be avoided by immediately releasing the "UP" button and reducing the load to within the hoist load rating.

#### CAUTION

The overload limiting clutch is an emergency protective device and should not be used to measure the maximum load to be lifted, or to sense the overload imposed by a constrained load. Manufacturing tolerances require that the clutch be set somewhat above the load rating of the hoist. The fact that the hoist will pick up loads in excess of its load rating does not in any way sanction the use of the hoist in an overloaded condition.

## SECTION IV INSPECTION

### 4-1. General

A scheduled inspection routine should be established for this hoist based upon severity of use and environmental conditions. Some inspections should be made frequently (daily to monthly) and others periodically (monthly to yearly). It is suggested that an Inspection and Maintenance Check List and an Inspector's Report similar to those shown in Figures 4-1 and 4-2 be used and filed for reference. All inspections should be made by a designated inspector. Special inspections should be made after any significant repairs or any situation causing suspicion that the hoist may have been damaged. Any hoist which has been removed from service for an extended time should receive an inspection as described under Periodic Inspections. ANSI B30.16, Safety Standard for Overhead Hoists, provides guidelines for hoist operation and inspection.

#### CAUTION

Any unsafe condition disclosed by any inspection must be corrected before operation of the hoist is resumed.

### 4-2. Frequent Inspection

- a. Check pushbutton station, brake, and limit switches for proper operation.
- b. Check hooks for deformation, chemical damage, or cracks. Bent hooks or hooks damaged from chemicals, deformation, cracks, or having excessive throat opening (see paragraph 4-6) should be replaced. Visible deformation of any hook may be evidence of hoist abuse and overloading and indicates that a thorough inspection of the complete hoist should be made.
- c. Check that bottom hook swivels freely.
- d. Check for missing, bent or otherwise damaged hook latches.
- e. Check pushbutton and power cord for cuts or other damage.

### 4-3. Periodic Inspection

The exact period for the following inspections will depend on the anticipated severity of hoist use. Determination of this period should be based on the user's experience. It is recommended that the user begin with a monthly inspection and extend the periods to quarterly, semi-annually, or annually, based on his monthly inspection experience.

- a. Clean hoist of any dirt or foreign material. Inspect bottom block for accumulation of debris.
- b. Perform all frequent inspections listed above.
- c. Check for loose bolts, screws and nuts.
- d. Check housings, load block, and other parts for wear, corrosion, cracks or distortion. Check for abnormal openings between housing sections.
- e. Check motor brake for worn discs, oil contamination or excessive clearance (see paragraph 5-3).
- f. Check mechanical load brake function (see Figure 4-3).
- g. Inspect the entire length of chain for gouges, nicks, weld spatter, corrosion, distortion and wear. See CHAIN INSPECTION, paragraph 4-5.
- h. Inspect hooks and suspension parts for cracks, distortion or extreme wear.
- i. Inspect hooks for cracks using magnetic particles, dye penetrant or other crack detecting methods.
- j. Check limit switch set points and reset if necessary (see paragraph 5-2).
- k. Inspect all wiring for defective insulation, and check to be sure all electrical connections are tight. Check motor reversing contactor or relay for burned contacts.
- l. Inspect for oil leaks. Check oil level.
- m. Inspect for missing or illegible capacity or warning labels.
- n. Inspect the supporting structure for continued ability to support the hoist rated load.

### INSPECTION & MAINTENANCE CHECK LIST ELECTRIC POWERED OVERHEAD CHAIN HOIST

Type of Hoist \_\_\_\_\_  
 Location \_\_\_\_\_  
 Manufacturer \_\_\_\_\_

Capacity (Tons) \_\_\_\_\_  
 Original Installation Date \_\_\_\_\_  
 Manufacturer's Serial No. \_\_\_\_\_

Item	Frequency of Inspection			Possible Deficiencies	OK	Action Required
	Frequent		Periodic 1-12 Mo.			
	Daily	Monthly				
Operating Controls	●	●	●	Any deficiency causing improper operation		
Limit Switches	●	●	●	Any deficiency causing improper operation Pitting or deterioration		
Disc (Motor) Brake	●	●	●	Slippage or excessive wear Glazing, contamination or excessive wear		
Load Brake (Mechanical)			●	Failure to support load with disc brake open (see paragraph 4-3.f)		
Hooks	●	●	●	Excessive throat opening, bent or twisted more than 10 degrees, damaged hook latch, wear, chemical damage, worn hook bearing Cracks (use dye penetrant, magnetic particle or other suitable detection method)		
Suspension Lug (if used)			●	Cracks, excessive wear or other damage which may impair the strength of the lug Cracks (use dye penetrant, magnetic particle or other suitable detection method)		
Chain	●	●	●	Inadequate lubrication, excessive wear or stretch, cracked, damaged or twisted links, corrosion or foreign substance		
Hook and Suspension Lug Connections			●	Cracks, bending, stripped threads, loose mounting screws		
Pins, Bearings, Bushings, Shafts, Couplings, Chain Guides			●	Excessive wear, corrosion, cracks, distortion		
Nuts, Bolts, Rivets			●	Looseness, stripped and damaged threads, corrosion		
Sheaves			●	Distortion, cracks, and excessive wear Build up of foreign substances		
Housings, Load Block			●	Cracks, distortion, excessive wear. Internal build up of foreign substances.		
Wiring and Terminals			●	Fraying, defective insulation		
Contact Block, Magnetic Hoist Control Switch, Other Electrical Apparatus			●	Loose connections, burned or pitted contacts		
Supporting Structure and Trolley (if used)			●	Damage or wear which restricts ability to support imposed loads		
Nameplates, Decals, Warning Labels			●	Missing, damaged or illegible		
Transmission Lubricant			●	Low Level, Requires Changing		

NOTE: Refer to Maintenance and Inspection Sections of the Hoist Maintenance Manual for further details.

**FREQUENCY OF INSPECTION:**

- Frequent — Indicates items requiring inspections daily to monthly. Daily inspections may be performed by the operator if properly designated.
- Periodic — Indicates items requiring inspection monthly to yearly. Inspections to be performed by or under the direction of a properly designated person. The exact period of inspection will depend on frequency and type of usage. Determination of this period will be based on the user's experience. It is recommended that the user begin with a monthly inspection and extend the periods to quarterly, semi-annually or annually based on his monthly experience.

**FIGURE 4-1. RECOMMENDED INSPECTION AND MAINTENANCE CHECK LIST**



INSPECTOR'S REPORT			
ITEM	REMARKS (LIST DEFICIENCIES AND RECOMMENDED ACTION)		
INSPECTOR'S SIGNATURE	DATE INSPECTED	APPROVED BY	DATE

**FIGURE 4-2. RECOMMENDED INSPECTOR'S REPORT**

**4-4. Load Brake Function Check**

To check the functioning of the mechanical load brake, proceed as follows:

- a. Attach a light load to the hoist and lift it several inches.
- b. **DISCONNECT HOIST FROM POWER SUPPLY** and remove short end brake cover (see Figure 8-1, Index No. 1).
- c. Referring to Figure 4-3 and Figure 8-8, place screwdrivers No. 1 and No. 2 behind the plate and armature assembly and prepare to pry against the transmission cover.

**NOTE**

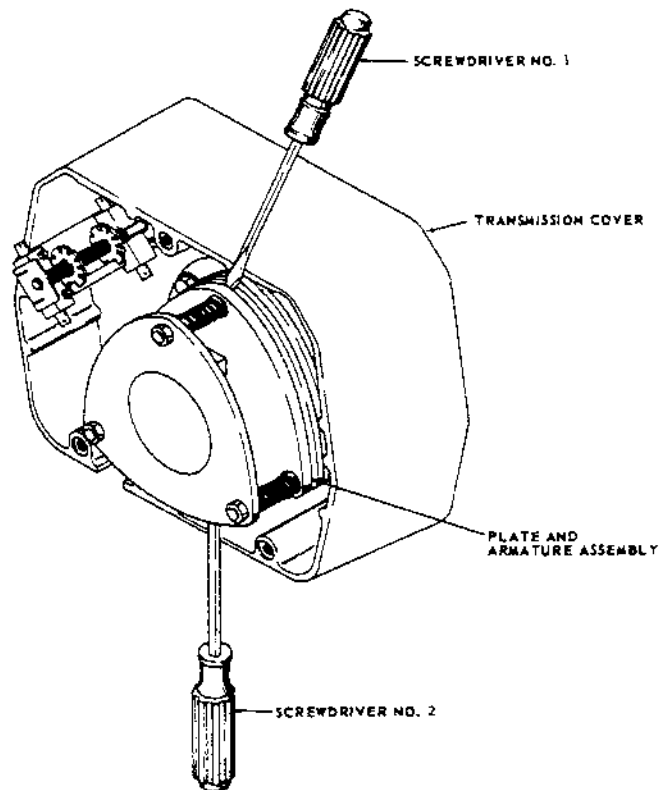
Do not allow either screwdriver to contact brake disc (see Figure 8-8, Index No. 7).

- d. Carefully pry open motor brake (close solenoid gap) and observe action of load. If the load descends, the mechanical load brake is malfunctioning and must be repaired.

**4-5. Chain Inspection**

Chain inspection and lubrication are the most important aspects of hoist maintenance. Removal of the chain from the hoist usually is not necessary, but the chain should be run through the hoist enough that every link is made visible for inspection.

- a. Check each link for gouges, nicks, weld spatter, corrosion and distortion.



**FIGURE 4-3. LOAD BRAKE FUNCTION CHECK**

- b. inspect each link for wear to the diameter of the link (see Figure 4-4). The nominal link diameter is 0.437 inch. If the diameter of any link of chain is worn to less than 0.350, the entire chain must be replaced.

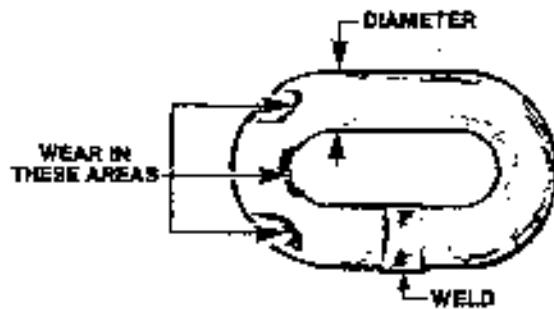


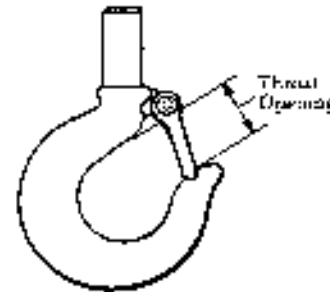
FIGURE 4-4. TYPICAL WEAR ON LINKS

- c. 1.) Check the chain for overall wear or stretch by selecting an unworn, unstretched length of chain (at the slack end, for example). Let the chain hang vertically with a light load (about 20 lbs.) on the chain to pull it taut. Use a large caliper to measure the outside length of a convenient number of links (about 12 inches). Measure the same number of links in a used section of chain and calculate the percentage increase in length of the worn chain.
- 2.) If the length of the worn chain is more than 1 1/2% longer than the unused chain (0.015" per inch of chain measured), then the chain should be replaced. If the chain is worn less than 1 1/2%, check it at several more places along its length. If any section is worn more than 1 1/2%, the chain should be replaced.

- d. The chain used in this hoist is accurately calibrated to operate over the load sprocket and is very carefully heat treated to maximum wear life and strength.

**WARNING**

1. Do not weld or join hoist load chain.
2. Do not substitute another manufacturer's chain in this hoist
3. Damage or wear, beyond the stated limits, to any portion of the chain requires that the entire length be replaced.



**4-6. Hook Throat Opening**

Use Table 4-1 (below) to check hook throat opening.

**TABLE 4-1. MAXIMUM ALLOWABLE HOOK THROAT OPENING**

Hoist Load Rating (ton)	Top Hook* (in.)	Bottom Hook* (in.)
1 & 2	1 1/8	1 3/16
3 & 4	1 5/8	1 5/8
5	N/A	1 3/4

\*Figures given are for hook with latch. Add 1/16" if measured without latch.

**SECTION V**

**MAINTENANCE AND REPAIR**

**5-1. General**

This section provides instructions for the most common routine maintenance and adjustments. Major repairs are not within the scope of this manual and should be referred to qualified service facilities.

**SAFETY NOTE**

Always remove load and disconnect hoist from power supply before removing end covers or making repairs.

**5-2. Limit Switch Adjustment**

Limit switches are provided to protect the hoist against damage resulting from overtravel. For easy identification, the upper (No. 2, Figure 5-1) and lower (No. 3, Figure 5-1) limit switch adjusting nuts are colored brass and zinc respectively. Each limit switch nut has ten slots for adjustment, and the increment of adjustment is such that one slot is equivalent to one link of chain travel. Care should be exercised when adjusting either limit of travel. When a geared type limit switch is furnished (long lift hoists) each adjustment is equal to 2 links of chain, or 30 links per revolution.

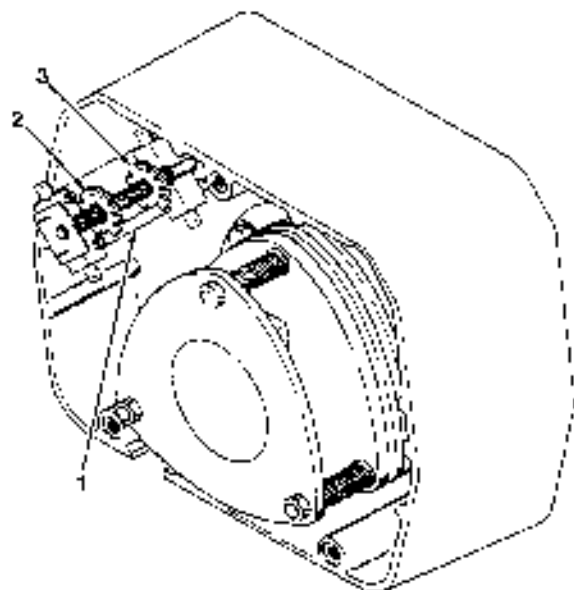


FIGURE 5-1. LIMIT SWITCH ADJUSTMENT

#### a. Adjusting Upper Limit (Brass Nut).

- 1.) Carefully raise the load block to a point where its top is 3" or more from the hoist housing.
- 2.) DISCONNECT POWER from the hoist and remove the short end cover.
- 3.) With a screwdriver, pry the spring guide plate (No. 1, Figure 5-1) out of the slots in the colored limit switch nuts (Nos. 2 and 3).
- 4.) Turn the slotted brass nut (No. 2) toward its limit switch until the switch clicks.
- 5.) Release the spring guide plate and be sure it snaps back into the slots in both nuts. Do not disturb the other slotted nut if it has been previously set.
- 6.) Replace the short end cover and reconnect power to the hoist.
- 7.) Carefully raise the load block to its upper limit and observe to see if it stops automatically at the desired point. Do not allow the load block to run into the hoist housing. The stopping point should be at least 3" below the hoist housing.

#### b. Adjusting Lower Limit (Zinc Nut)

- 1.) Carefully lower the load block to a point where at least 12 links of slack chain hang down from the hoist housing.
- 2.) DISCONNECT POWER from the hoist and remove the short end cover.
- 3.) Adjust the zinc limit switch nut in the same manner described above for the red nut.
- 4.) Replace the short end cover and reconnect power to the hoist.
- 5.) Carefully lower the load block to its lower limit and observe if it stops automatically at the desired level. Do not run chain out of hoist or allow the slack end loop to become taut against the hoist housing. At least 12 links of slack chain should hang from the hoist.

#### NOTE

If upper and lower limits are not operating satisfactorily, repeat adjustment.

### 5-3. Motor Brake Adjustment

When properly adjusted, the multiple disc motor brake should release promptly, operate without noticeable chatter, and stop the load with no more than one inch of drift. If the hoist hesitates to lift the load promptly when the pushbutton is depressed, the brake should be adjusted per the following procedure.

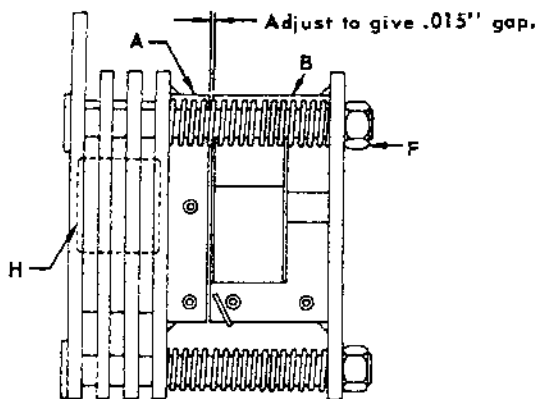


FIGURE 5-2. MOTOR BRAKE ADJUSTMENT

- a. Remove any load and DISCONNECT POWER from hoist.
- b. Remove the short end cover.
- c. Referring to Figure 5-2, check the gap between armature (A) and frame (B). The correct gap is .015".

- d. Adjust the gap by turning the three lock nuts (F) and check with a feeler gauge to be sure the gap is the same on both ends of the solenoid.

#### CAUTION

Be sure the bottom of the armature does not touch the splined adapter (H). As wear occurs, the original clearance will be reduced. When this clearance is gone, THE BRAKE DISCS MUST BE REPLACED.

- e. Replace short end cover and reconnect power. If the brake still chatters or is hesitant to release, refer to Section VI, Troubleshooting.

### 5-4. Top Suspension Removal and Replacement

A number of different top suspension assemblies are available to accommodate different methods of hanging the hoist. If it should be necessary to change top suspensions, proceed as follows:

- a. DISCONNECT POWER from hoist and move the hoist to a safe working area. If necessary, remove trolley to gain access to the cap screws bolting the top suspension to the frame of the hoist.
- b. Remove cap screws and lift off the suspension assembly.

#### NOTE

Due to the variety of mounting arrangements and different reevings available on EC-3 Series hoists it is possible for any suspension assembly to be mounted in several positions. Refer to the diagrams of Figure 5-3 for proper suspension location and orientation.

- c. Check to be sure proper length cap screws are being used with any change of top suspension. Screws should have  $\frac{3}{4}$  inch thread engagement.
- d. Install new suspension assembly and tighten cap screws to 75 ft.-lbs. torque.

### 5-5. Chain Replacement (Old chain still in hoist)

Refer to Figure 5-5, Chaining Diagrams, and proceed as follows:

- a. Run the load block up to its top limit.
- b. DISCONNECT POWER from the hoist and remove the short end cover.
- c. With a screwdriver, push the spring guide plate (No. 1, Figure 5-1) out of the slots in the limit switch nuts. Turn the brass slotted nut (2) back to about the center of the threaded screw. DO NOT DISCONNECT THE WIRES FROM THE LIMIT SWITCHES.
- d. Remove the load hook assembly from the old chain.
- e. Make a "C"-shaped chain link by grinding through one side of the end link of either the old or new chain. See Figure 5-4.
- f. Hook the special "C" link to the end link of both chains thus joining them. BE SURE the welds of the upstanding links of the new chain are out away from the load sheave, and that proper orientation is observed for attachment of the slack end in paragraph j. below.
- g. With the end cover off, connect the hoist to power supply. Be sure the green ground wire is properly grounded.
- h. Carefully jog the "UP" button and run the joined pieces of chain into the hoist until about 12 inches of the new chain comes out the other side.
- i. DISCONNECT POWER from the hoist.

Continued on page 13

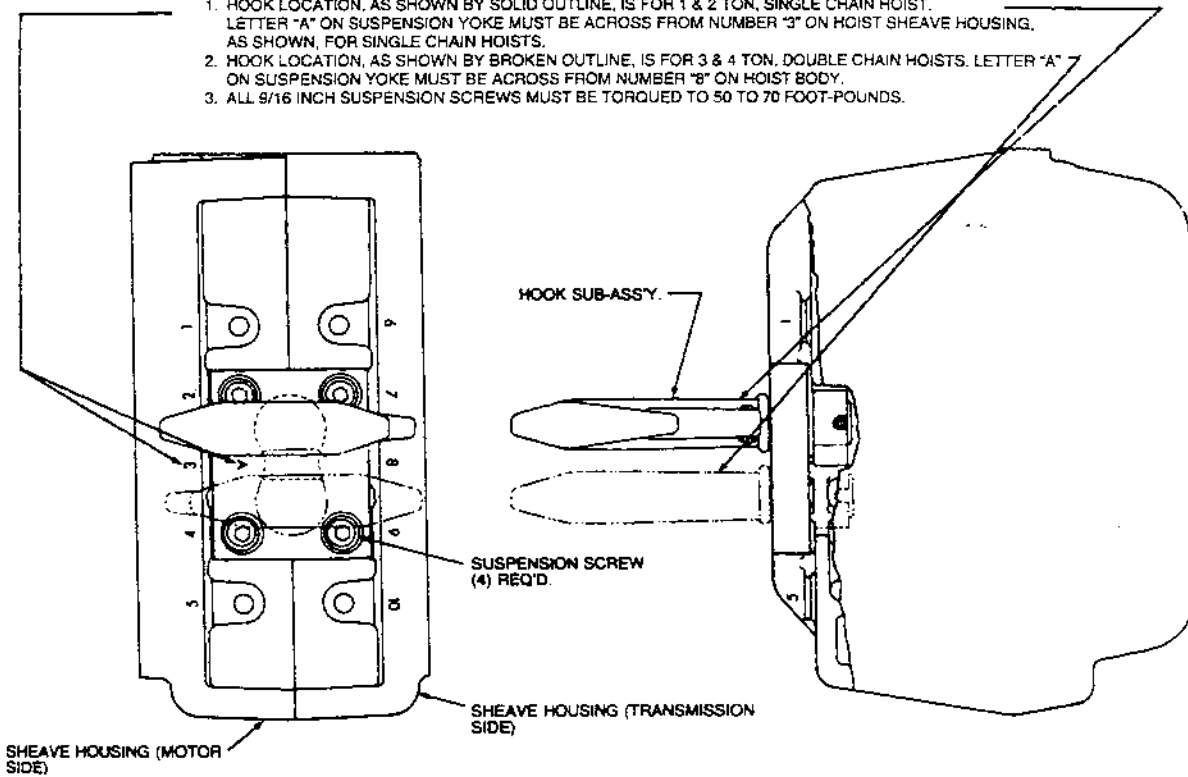
All standard top suspensions will be marked with a letter. Hoist center sections have each tapped mounting hole marked by a cast-in number. In order to obtain proper alignment of the top suspension with the load block, letters and numbers must

be placed adjacent to each other according to the following table. When specified, spacers are used between the suspension and the hoist frame. See Section 5-4 for suspension change procedure.

Top Suspension	Hoist Capacity	Suspension Letter	Hoist Number	Spacer Length
Swivel or Rigid Hook	1, 2 Ton	A	3	None
	3 or 4 Ton	A	8	None
3 <sup>5</sup> / <sub>8</sub> " Square Box With Plain Trolley or Parallel Mount Motorized Trolley	1, 2 Ton	B	9	None
	3 Ton	B	2	None
3 <sup>5</sup> / <sub>8</sub> " Square Box With Cross Mount Motorized Trolley	1, 2 Ton	B	9	1 <sup>1</sup> / <sub>16</sub> "
	3 Ton	B	2	1 <sup>1</sup> / <sub>16</sub> "
7" Square Box With Trolley	4 Ton	C	3	None
	5 Ton	D	5	None
8 Wheel Plain Trolley	4 Ton	B	2	1 <sup>1</sup> / <sub>16</sub> "
	5 Ton	D	5	1 <sup>1</sup> / <sub>16</sub> "
8 Wheel Motorized Trolley	4 Ton	B	2	1 <sup>3</sup> / <sub>4</sub> "
	5 Ton	D	5	1 <sup>3</sup> / <sub>4</sub> "

**RIGID, PARALLEL HOOK SUB-ASSEMBLY ORIENTATION**

1. HOOK LOCATION, AS SHOWN BY SOLID OUTLINE, IS FOR 1 & 2 TON, SINGLE CHAIN HOIST. LETTER "A" ON SUSPENSION YOKE MUST BE ACROSS FROM NUMBER "3" ON HOIST SHEAVE HOUSING, AS SHOWN, FOR SINGLE CHAIN HOISTS.
2. HOOK LOCATION, AS SHOWN BY BROKEN OUTLINE, IS FOR 3 & 4 TON, DOUBLE CHAIN HOISTS. LETTER "A" ON SUSPENSION YOKE MUST BE ACROSS FROM NUMBER "8" ON HOIST BODY.
3. ALL 9/16 INCH SUSPENSION SCREWS MUST BE TORQUED TO 50 TO 70 FOOT-POUNDS.



**EXAMPLE: RIGID, PARALLEL HOOK SUSPENSION ARRANGEMENT**  
1, 2, 3 & 4 TON HOISTS

**FIGURE 5-3. TOP SUSPENSION ORIENTATION**

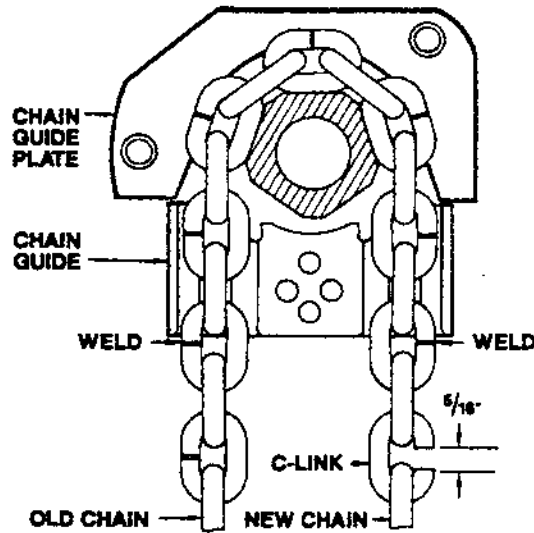


FIGURE 5-4. CHAINING HOIST

**5-6. Lubrication**

Proper lubrication is necessary for long, trouble-free hoist operation. Refer to the following and to Table 5-1, Recommended Lubrication Schedule, for lubrication points, type of lubricant, and frequency of lubrication.

- a. **Load Chain.** Clean the load chain with a non-acid and non-caustic solvent and coat with SAE 90 gear oil. Wipe excess oil to prevent dripping. If the hoist is used in an atmosphere containing abrasive dust, the chain should be cleaned and oiled more frequently. Never apply grease to the chain.
- b. **Gearing.** The gear case of the hoist is filled at assembly with 1 gal. of a gear oil containing special friction-reducing additives.

**WARNING**

The use of gear oils other than that recommended in Table 5-1 can cause brake chatter or can render the load brake incapable of holding a load. A 1 gal. container of this oil is available from Coffing (Part No. 14J11).

- a. **To check the oil level,** remove the 1/4" pipe plug from the side of the hoist. With the hoist hanging level, transmission oil should be even with the edge of the tapped plug hole.
- b. The length of time between necessary oil changes will depend on the severity of use the hoist receives. In general, the oil should be changed every 12 months of normal operation, or every 200 hours of actual hoist on-time. Very heavy use or operation in high ambient temperatures (over 105°F) will require that oil be changed more often. An indication of the need for oil replacement is load brake noise. If an erratic tapping sound is made when lowering a load, the oil should be changed.
- c. **Limit Switch Shaft.** To prevent rust, the threaded limit switch shaft should be given a light coat of grease or sprayed with a general purpose lubricant.
- d. **Idler Sheave Bearing (double and triple chain models only).** Use a grease gun to put about a teaspoon of grease through the grease fitting in the bottom block shaft. Avoid pumping an excessive amount of grease into the bottom block. On triple chain hoists, use a grease gun to lubricate the idler sheave in the hoist until fresh grease pumps from the ends of the sheave.
- e. **Hook Bearing.** Apply a few drops of SAE 30 oil around the edge of the bearing.

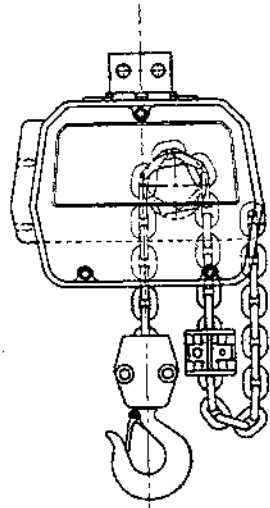
- j. Remove both the "C" link and the old chain from the slack end pin (No. 13, Figure 8-6). This can be accomplished by depressing the pin against the slack end spring (14) with a small screwdriver. Depress the slack end pin and install the new chain observing proper orientation of the slack end of the chain when secured. Avoid twists in the chain.
- k. Adjust the lower limit switch per paragraph 5-2.b.
- l. Attach the bottom hook on single-chained hoists to the loose end of the chain. On double-chained hoists, feed the loose end of the chain through the load block (welds of the upstanding links will be in towards the sheave) and fasten the end of the chain to the dead end pin (No. 17, Figure 8-6B).  
On triple chain hoists, feed the loose end of the chain through the load block (welds toward sheave), around the idler sheave in the hoist, and to the center of the load block.
- m. Adjust the upper limit switch per paragraph 5-2.a.
- n. Lubricate the new chain per paragraph 5-6.a and perform an operation test of the hoist.

TABLE 5-1. RECOMMENDED LUBRICATION SCHEDULE\* MODEL EC ELECTRIC CHAIN HOIST

Component	Type of Lubricant	Type of Service and Frequency of Lubrication		
		Heavy	Normal	Infrequent
Load Chain	SAE 90 Gear Oil	Daily	Weekly	Monthly
Gearing	Coffing No. H-7813 transmission oil (Kit No. 14J11 contains quantity of oil sufficient for one oil change)	At periodic inspection (See Figure 4-1, paragraph 5-6-b)		
Limit Switch Shaft	"WD-40" or general purpose spray lubricant	Monthly	Yearly	Yearly
Load Hook Bearing	SAE 30 Gear or Motor Oil	Weekly	Monthly	Yearly
Idler Sheave Bearing (Bushing)	NLGI #2 multi-purpose lithium base grease (Coffing No. H-7610)	At periodic inspection (See Figure 4-1)		

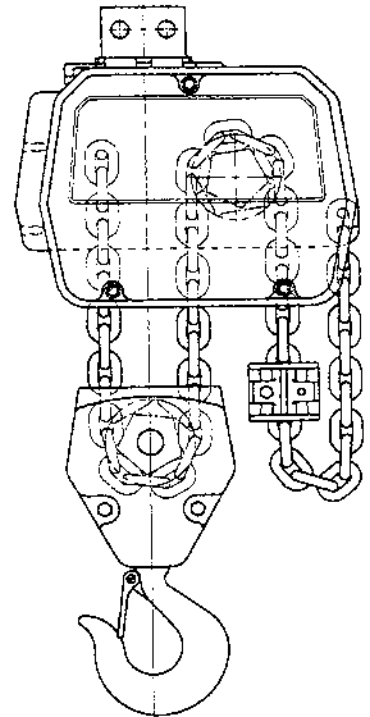
NOTE: All bearings except hook and idler sheave bearings are prelubricated and sealed.

\*This lubrication schedule is based on a hoist operating in normal environmental conditions. Hoists operating in adverse atmospheres containing excessive heat, corrosive fumes or vapors, abrasive dust, etc., should be lubricated more frequently.

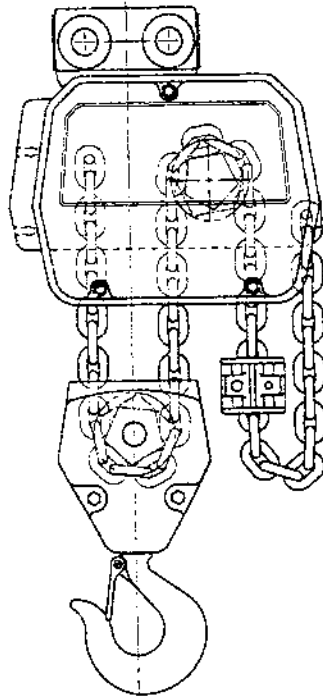


Single Chain  
1 & 2 Ton Hoist

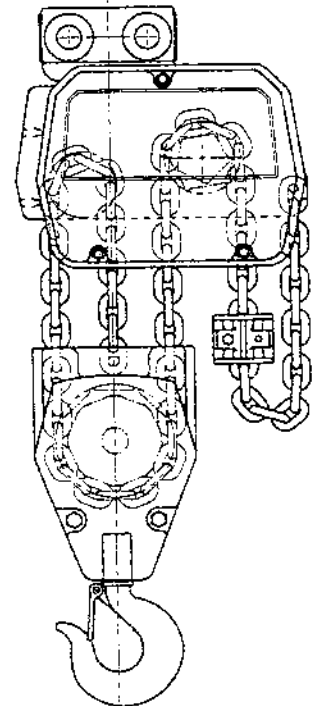
**CAUTION:** Top Suspension must be centered over bottom hook. See Fig. 5-3 Top Suspension orientation.



Double Chain  
3 Ton Hoist



Double Chain  
4 Ton Hoist



Triple Chain  
5 Ton Hoist

AS VIEWED FROM BRAKE COVER  
END OF HOIST (1, FIGURE 8-1)

**FIGURE 5-5. CHAINING DIAGRAMS**

**5-7. Chain Stop Installation**

Refer to Figures 8-6A, 6B and 6C, Chaining Parts, and proceed as follows:

- a. Disconnect slack end of chain from hoist.
- b. Count (approx.) 12 links from slack end of chain and capture the twelfth link with the two stop halves.
- c. Install and tighten the two cap screws.

- d. If no chain container is used, reattach the slack end of the chain to the hoist. If a chain container is used, drop the slack end of the chain into chain container.
- e. Readjust "down" limit switch as necessary to give a minimum clearance of 1 1/2" between chain stop end and bottom of hoist.

**WARNING**

**This is a safety device only and is not intended to be a substitute for the limit switch in the hoist.**

**SECTION VI  
TROUBLESHOOTING**

**6-1. General**

Use the following table as an aid to troubleshoot your hoist. If you do not have an experienced machinist-electrician to do your

repair work, we recommend that you send your hoist to an approved service center for repairs.

TROUBLE	REMEDY
---------	--------

**Hook Fails to Stop at End of Travel.**

<ul style="list-style-type: none"> <li>1. Limit switches not operating.</li> <li>2. Limit switch nuts not moving on shaft.</li> <li>3. Magnetic reversing switch malfunction.</li> </ul>	<ul style="list-style-type: none"> <li>1. Check adjustment. See paragraph 5-2. Check connections against wiring diagram. Tighten loose connections or replace.</li> <li>2. Check for stripped threads or bent nut guide.</li> <li>3. Remove electrical cover and check reversing switch.</li> </ul>
--	---

**Hoist Does Not Respond to Pushbutton.**

<ul style="list-style-type: none"> <li>1. Power failure in supply lines.</li> <li>2. Wrong voltage or frequency.</li> <li>3. Improper connections in hoist or pushbutton station.</li> <li>4. Motor brake does not release.</li> <li>5. Faulty magnetic hoist control switch.</li> </ul>	<ul style="list-style-type: none"> <li>1. Check circuit breakers, switches and connections in power supply lines.</li> <li>2. Check voltage and frequency of power supply against the rating on the nameplate of the hoist.</li> <li>3. Check all connections at line connectors and on terminal block. Check terminal block on dual-voltage hoists for proper voltage connections.</li> <li>4. Check connections to the solenoid coil. Check for open or short circuit. Check for proper adjustment. See paragraph 5-3.</li> <li>5. Check coils for open or short circuit. Check all connections in control circuit. Check for burned contacts. Replace as needed.</li> </ul>
--	--

**Hook Does Not Stop Promptly.**

<ul style="list-style-type: none"> <li>1. Hoist overloaded.</li> <li>2. Brake not holding.</li> </ul>	<ul style="list-style-type: none"> <li>1. Reduce load to within rated capacity of hoist.</li> <li>2. Check motor brake adjustment (see paragraph 5-3) and load brake (Figure 4-3).</li> </ul>
---	---

**Hook Moves in Wrong Direction.**

<ul style="list-style-type: none"> <li>1. Three-phase reversal.</li> <li>2. Improper connections.</li> </ul>	<ul style="list-style-type: none"> <li>1. Reverse any two wires (except the green ground wire) at the power source (see paragraph 2-3).</li> <li>2. Check all connections against Wiring Diagram.</li> </ul>
--	--

**Hoist Hesitates to Lift When Energized.**

<ul style="list-style-type: none"> <li>1. Hoist overloaded.</li> <li>2. Motor brake requires adjustment.</li> <li>3. Worn overload limiting clutch.</li> <li>4. Low voltage.</li> </ul>	<ul style="list-style-type: none"> <li>1. Reduce load within rated capacity of hoist.</li> <li>2. Check motor brake adjustment. See Figure 5-2.</li> <li>3. Replace clutch.</li> <li>4. Check voltage at hoist power cord with hoist starting. Voltage should be no less than 90% of voltage specified on hoist.</li> </ul>
---	---

TROUBLE	REMEDY
<b>Hook Raises But Will Not Lower. (Motor not running)</b>	
<ol style="list-style-type: none"> <li>1. "Down" circuit open.</li> <li>2. Broken conductor in pushbutton cable.</li> <li>3. Faulty magnetic hoist control switch.</li> </ol>	<ol style="list-style-type: none"> <li>1. Check circuit for loose connections. Check "Down" limit switch for malfunction.</li> <li>2. Check each conductor in the cable. If one is broken, replace entire cable.</li> <li>3. Check coils for open or short circuit. Check all connections in control circuit. Check for burned contacts. Replace as needed.</li> </ol>
<b>Hook Raises But Will Not Lower When Motor Is Operating.</b>	
Consult Factory or Authorized Coffing Warranty Repair Station.	
<b>Hook Lowers But Will Not Raise.</b>	
<ol style="list-style-type: none"> <li>1. Hoist overloaded.</li> <li>2. Low voltage.</li> <li>3. "UP" circuit open.</li> <li>4. Broken conductor in pushbutton cable.</li> <li>5. Faulty magnetic hoist control switch.</li> <li>6. Worn overload limiting clutch.</li> </ol>	<ol style="list-style-type: none"> <li>1. Reduce load to within rated capacity.</li> <li>2. Determine cause of low voltage and bring up to at least 10% of the voltage specified on hoist. Line voltage should be measured while holding or lifting load.</li> <li>3. Check circuit for loose connections. Check "UP" limit switch for malfunction.</li> <li>4. Check each conductor in the cable. If one is broken, replace entire cable.</li> <li>5. Check coils for open or short circuit. Check all connections in control circuit. Check for burned contacts. Replace as needed.</li> <li>6. Replace clutch.</li> </ol>
<b>Lack of Proper Lifting Speed.</b>	
<ol style="list-style-type: none"> <li>1. Hoist overloaded.</li> <li>2. Motor brake is dragging.</li> <li>3. Low voltage.</li> <li>4. Overload limiting clutch intermittently slipping.</li> </ol>	<ol style="list-style-type: none"> <li>1. Reduce load to within rated capacity of hoist.</li> <li>2. Check for proper brake adjustment or other defects. See paragraph 5-3.</li> <li>3. Bring up voltage to plus or minus 10% of voltage specified on hoist. Line voltage should be measured while hoist is lifting load.</li> <li>4. Replace clutch.</li> </ol>
<b>Load Brake "Noise." (Erratic tapping sounds or squeals)</b>	
<ol style="list-style-type: none"> <li>1. Need transmission oil change, or improper lubricant has been used.</li> <li>2. Load brake malfunctioning.</li> </ol>	<ol style="list-style-type: none"> <li>1. Change transmission oil. See Table 5-1. Note: Hoist Warranty is void if unapproved oil is used.</li> <li>2. Check load brake operation. See Figure 4-3.</li> </ol>
<b>Motor Brake Noise or Chatter. (While starting hoist)</b>	
<ol style="list-style-type: none"> <li>1. Brake needs adjustment.</li> <li>2. Low voltage.</li> </ol>	<ol style="list-style-type: none"> <li>1. Adjust as per paragraph 5-3.</li> <li>2. Check voltage at hoist power cord with hoist starting. Voltage should be no less than 90% of the voltage specified.</li> </ol>
<b>Motor Brake "Buzz." (Anytime hoist is running)</b>	
<ol style="list-style-type: none"> <li>1. Brake needs adjustment.</li> <li>2. Broken shading coil on brake frame.</li> </ol>	<ol style="list-style-type: none"> <li>1. Adjust as per paragraph 5-3.</li> <li>2. Replace shading coil or complete brake frame assembly.</li> </ol>



### SECTION VII WIRING

#### Safety Notes

Disconnect power from hoist before removing end covers.

#### 7-1. Voltage Conversion

Standard single speed units are convertible from 460 to 230 volts. Conversion to the alternate voltage can be accomplished with the following procedure.

- a. Be sure power is disconnected from hoist. Remove long end cover.
- b. To convert the hoist from 460 to 230 volts, reconnect leads T4, T5, T6, T7, T8, T9, H2, H3, S1, and S2 per the 230 volt connection diagram on Wiring Diagram, Figure 7-1.

#### CAUTION

Do not move any wires or make any changes to the wiring except at the gray terminal block.

- c. After converting voltage, check for proper phasing of three phase units and check for proper limit switch operation.

#### 7-2. Wiring Diagrams

The wiring diagrams for standard hoist models are reproduced on the following pages. In addition, every hoist should have a wiring diagram located inside the long end cover.

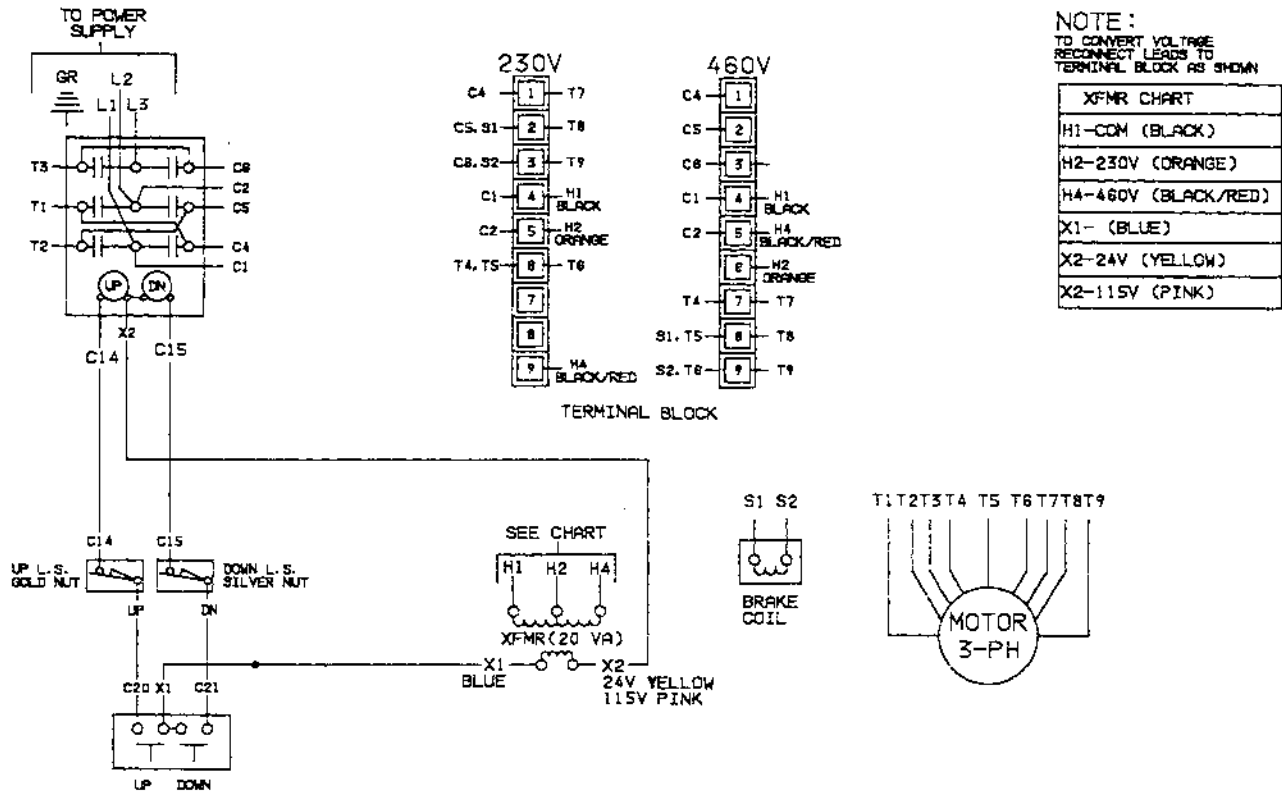


FIGURE 7-1. WIRING DIAGRAM  
230/460V, 3 Phase, Single Speed Hoist

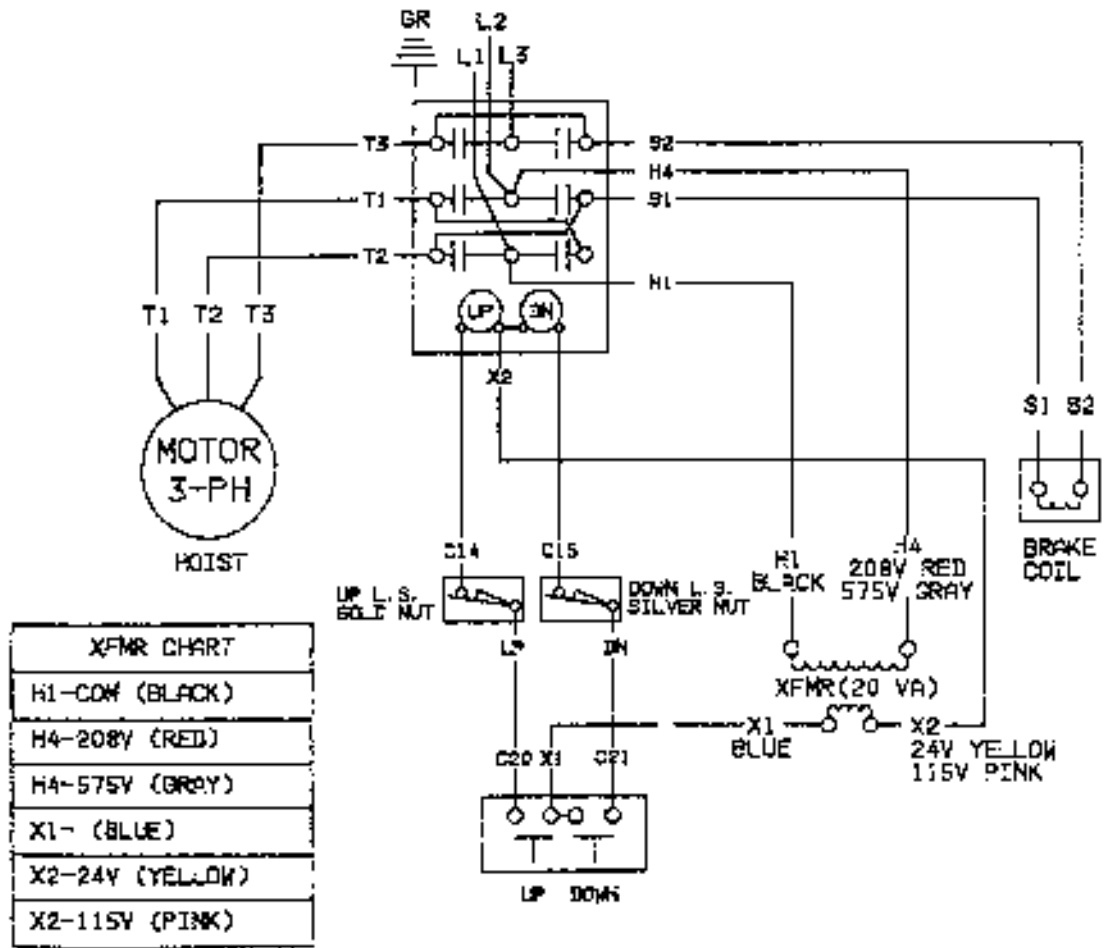
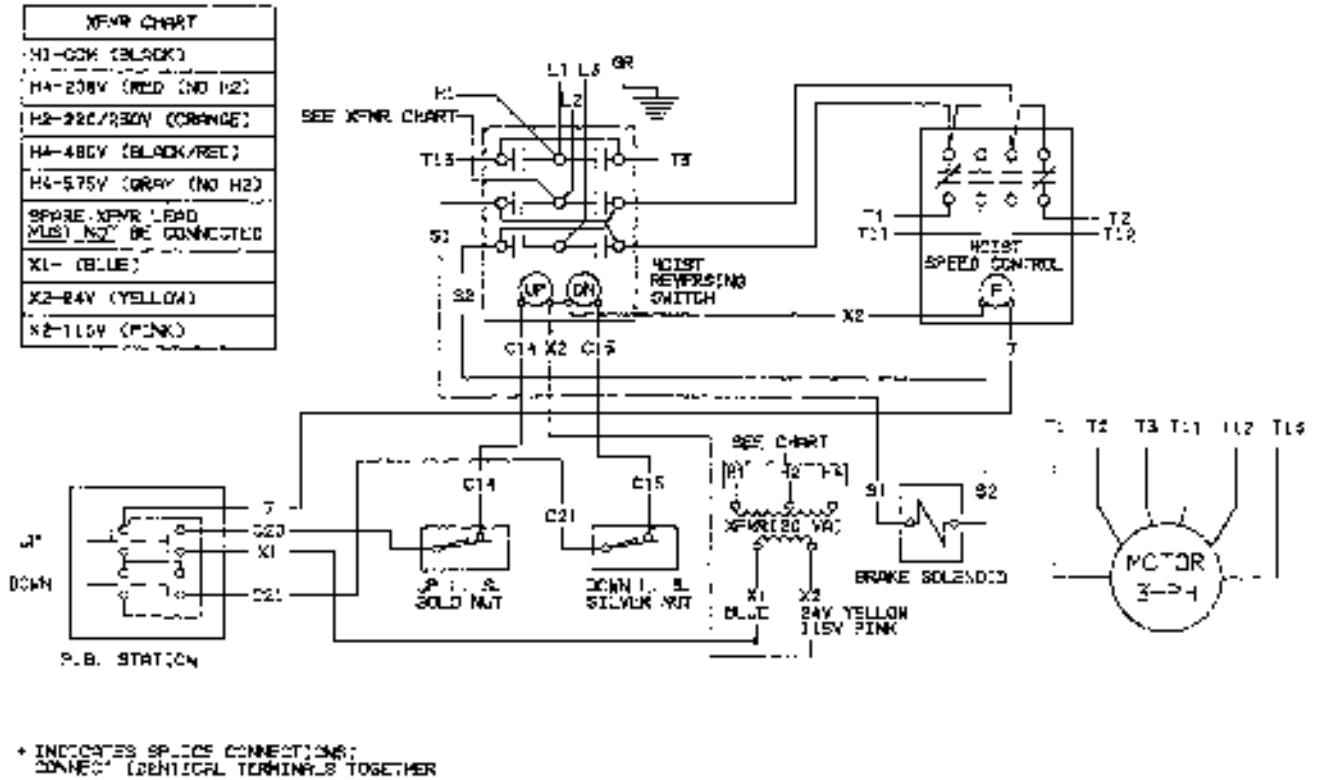


FIGURE 7-2. WIRING DIAGRAM  
208V or 575V, 3 Phase, Single Speed Hoist



**FIGURE 7-3. WIRING DIAGRAM**  
230, 480, 575 & 208V, 3 Phase, Two Speed Hoist

### SECTION VIII ILLUSTRATED PARTS LIST

#### 8-1. General

The following exploded drawings provide a complete list of parts used in the standard EC hoist models (shown in Table 1-1, page 3). Since several different models of hoists are covered by this manual, differences may be noted between the appearance of your hoist part and the reference illustration. If this is the case, the parts list will show several different part numbers with sufficient information to allow the selection of the correct part number.

#### 8-2. How to Use the Parts List

- a. The parts list consists of three columns as follows:
  - 1) Index Number
  - 2) Part Number
  - 3) In addition to basic part name, this column contains descriptions which are essential for choosing the correct part number when more than one is listed.

#### 8-3. How To Order Replacement Parts

When ordering parts or requesting information concerning your EC hoist, always include the hoist model number and serial number. Both numbers are permanently stamped on the transmission housing casting near the chain entrance area. See index No. 6, Figure 8-1 and illustration below.

**When ordering motor parts, please provide complete motor nameplate data, including motor "ref." number or model number.**

#### NOTE

Repair parts are available only from Coffing distributors or authorized repair facilities. It is recommended that repair part orders be directed to the authorized repair facility nearest you.

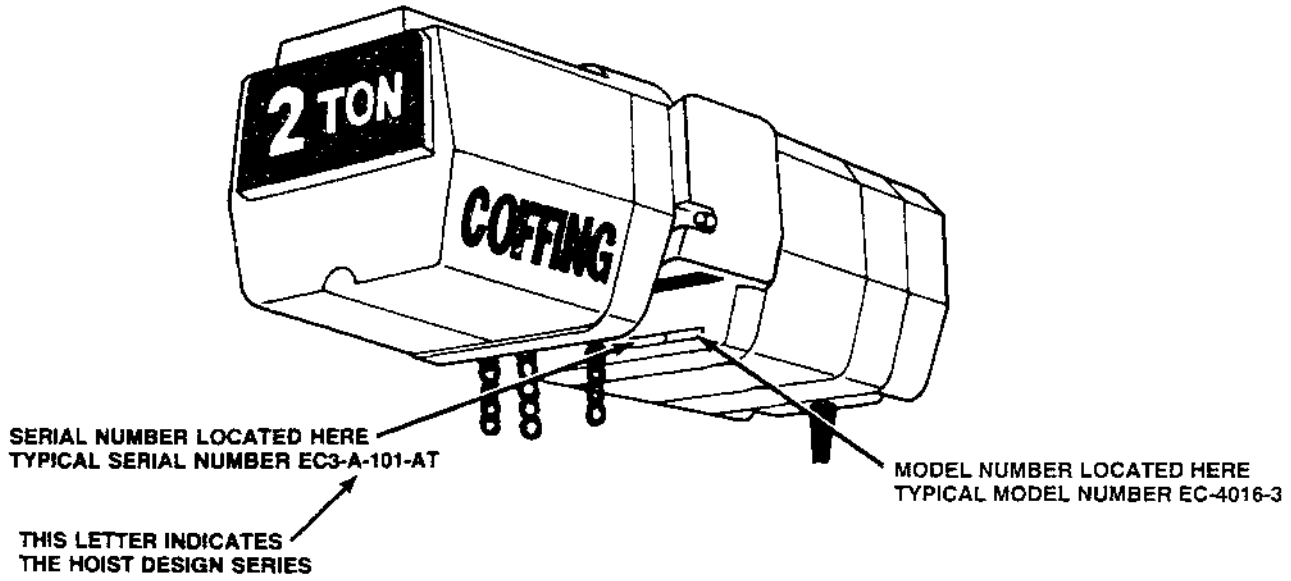
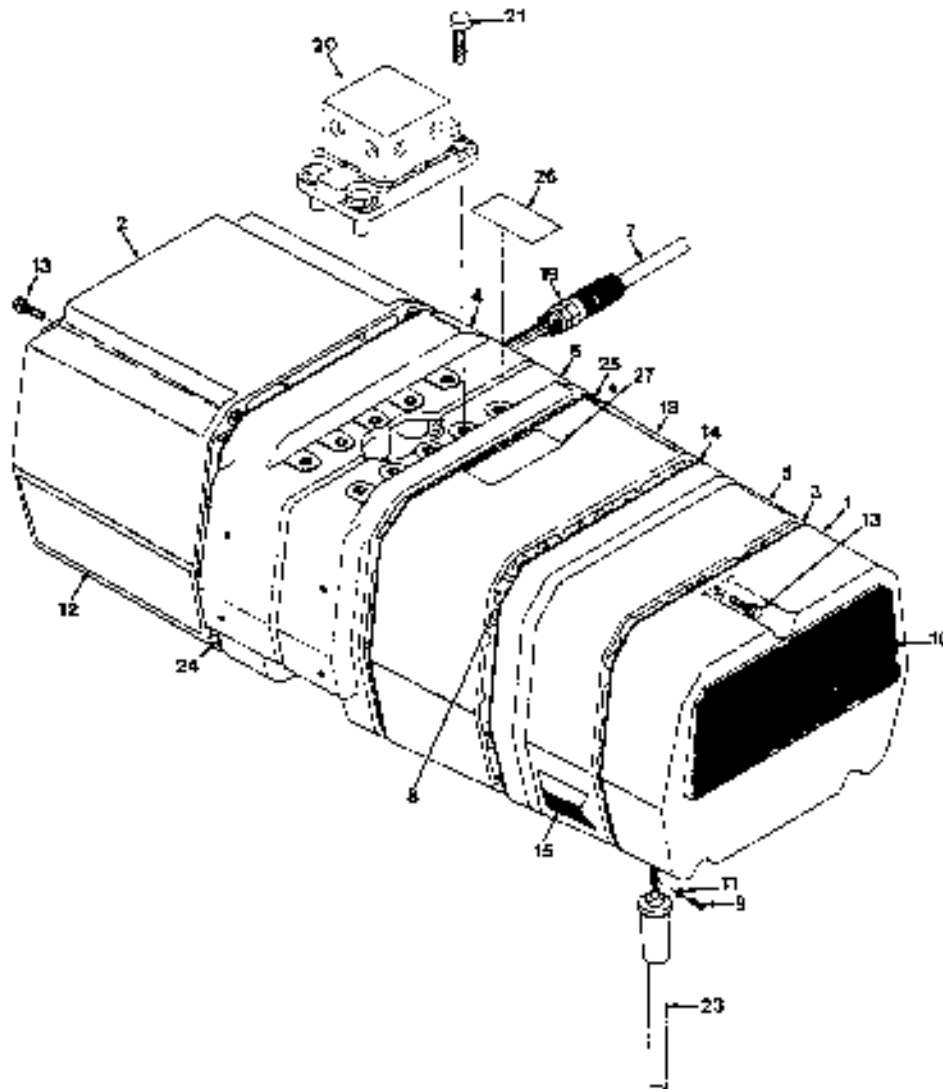


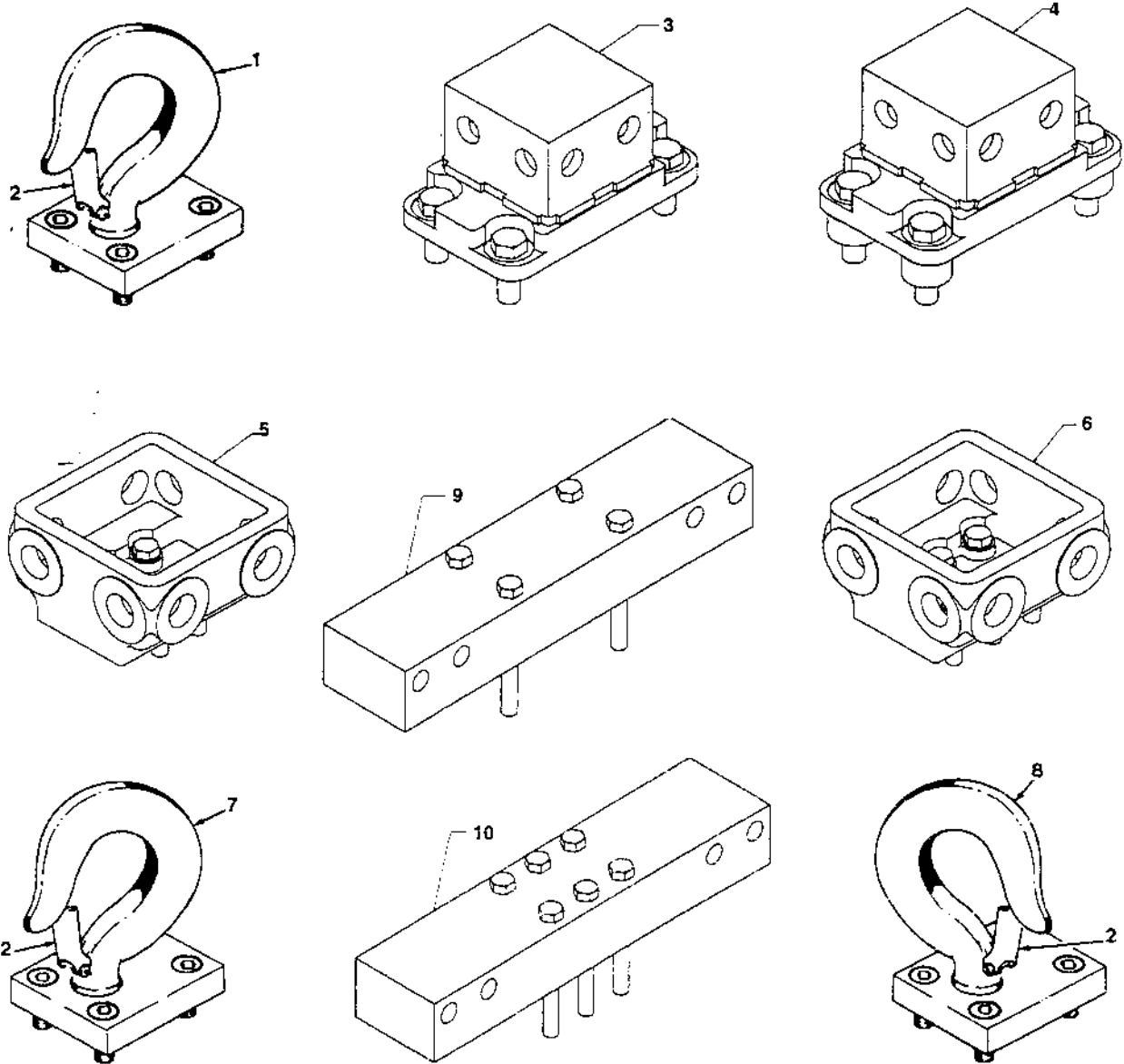
FIGURE 8-1. BASIC HOIST



Index No.	Part No.	Part Name
1	3614	Brake Cover
2	3613	Control Cover
3	26012	Gasket, Brake Covers
4	33113	Sleeve Housing, Motor Side
	33111	(1, 2, 3, & 4 ton)
		(5 ton)
5	3472	Transmission Cover
6	3716	Sleeve Housing, Transmission Side
		(1, 2, 3, & 4 ton)
		(5 ton)
7	H-6003	Power Cord
8	04014	Wiring Harness (Single Speed)
	91014-9	Wiring Harness (Two Speed)
9	H-3981-P	Screw
10	67517B	Decal, Capacity (1 Ton)
	67516	Decal, Capacity (2 Ton)
	67516	Decal, Capacity (3 Ton)
	67517	Decal, Capacity (4 Ton)
	67518	Decal, Capacity (5 Ton)
11	H-4002-P	Flange Washer
12	67712	Decal, Coiling
13	H-2687-P	Screw

Index No.	Part No.	Part Name
14	56106	Gasket, Transmission Cover
15	67612B	Decal, Coiling Hoists
16	67912	Decal, Power Requirements (230/460V)
	67913	Decal, Power Requirements (230V)
	67914	Decal, Power Requirements (460V)
	67915	Decal, Power Requirements (575V)
	67916	Decal, Power Requirements (208V)
18	3513	Transmission Housing
19	H-7961	Cool Gap
20		Suspension Assembly Kit (Reference—See figure 8-2)
21		Screw (Included in all suspension assy.) (Reference—See figure 8-2)
23		Push Button Cable (Reference—See figures 8-10A and 8-10B)
24	56013	Gasket, Control Covers
25	560K15	Gasket, Transmission Adapter
26	68711	Decal
27	687K9	Decal (Used with 3 1/2" suspension adapters)
	687K10	Decal (Used with 2" suspension adapters)

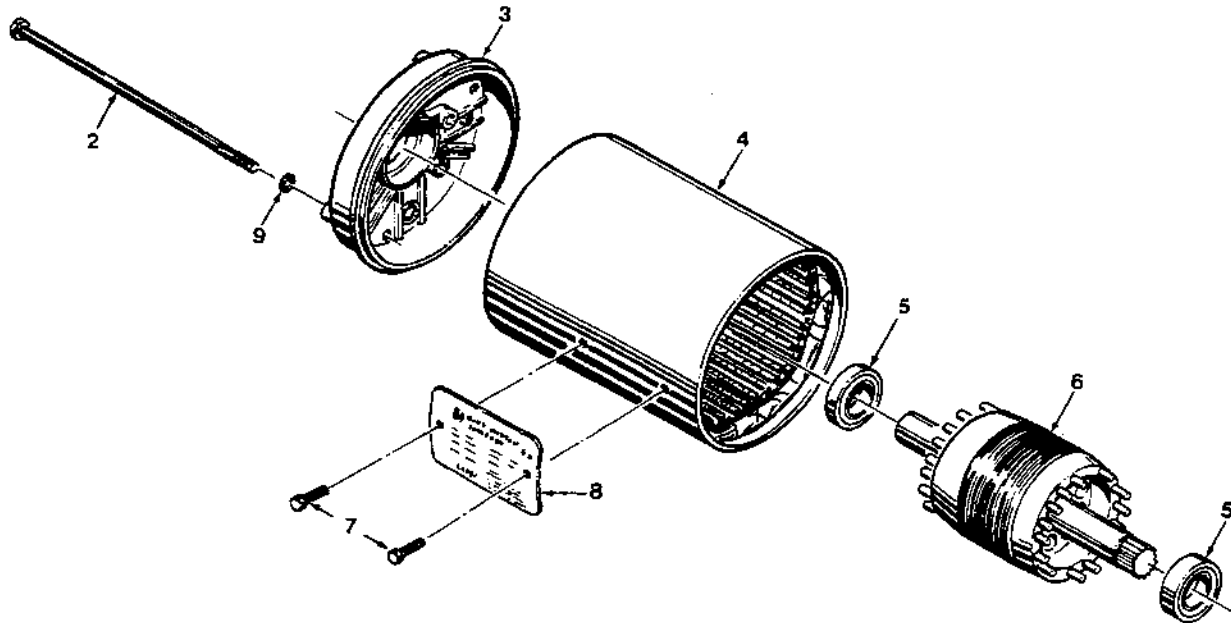
FIGURE 8-2. SUSPENSION ASSEMBLY KITS



Index No.	Part No.	Part Name
1	14J27	Swivel Hook Assembly, With Latch (1, 2, 3 & 4 Ton Models)
2	H-7545	Latch Kit
3	14J14	Trolley Lug Assembly (3 <sup>5</sup> / <sub>8</sub> " ), Plain and Geared Trolley—Parallel or Cross Mounted, Motorized Trolley—Parallel Mounted <u>ONLY</u> , (1, 2 & 3 Ton Models)
4	14J15	Trolley Lug Assembly (3 <sup>5</sup> / <sub>8</sub> " ), Motorized Trolley—Cross Mounted (1, 2 & 3 Ton Models)
5	14J16	Lug Suspension (7")—For 4 Ton Lug Mounted Hoist <u>ONLY</u>
6	14J18	Lug Suspension (7")—For 5 Ton Lug Mounted Hoist <u>ONLY</u>
7	14J28	Rigid Hook Assembly, With Latch, Cross Mounted
8	14J29	Rigid Hook Assembly, With Latch, Parallel Mounted (Standard)
9	***	Load Bar 4-Ton (Standard on 8-Wheel Trolley, Cross Mounted)
10	***	Load Bar 5-Ton (Standard on 8-Wheel Trolley, Cross Mounted)

\*\*\* Consult Factory for Kit No.

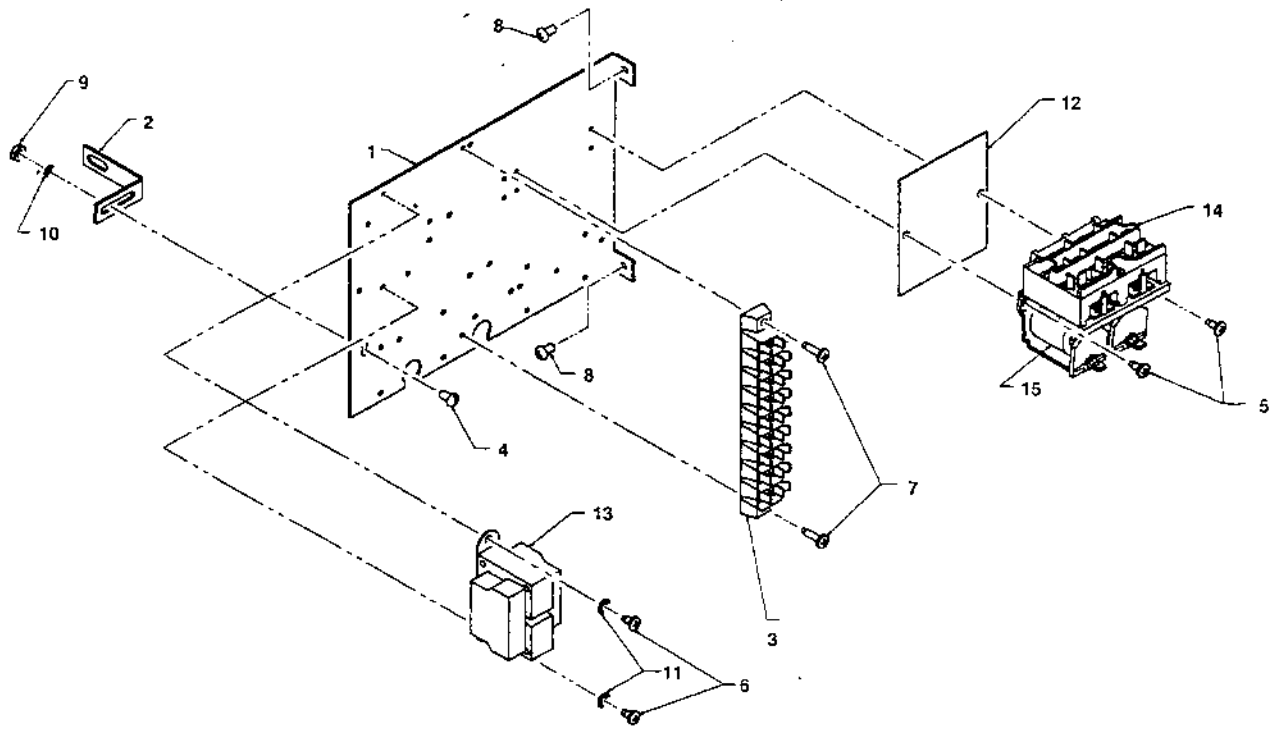
**FIGURE 8-3. MOTOR PARTS**



Index No.	Part No.	Part Name
1	863J401	2 HP Motor (230/460V)
	863J402	3 HP Motor (230/460V)
	863J403	2 HP Motor (575V)
	863J404	3 HP Motor (575V)
	863J405	2 HP Motor (208V)
	863J406	3 HP Motor (208V)
	873J401	2 HP Two-speed Motor (230V)
	873J402	3 HP Two-speed Motor (230V)
	873J403	2 HP Two-speed Motor (460V)
873J404	3 HP Two-speed Motor (460V)	
873J405	2 HP Two-speed Motor (575V)	
873J406	3 HP Two-speed Motor (575V)	
873J407	2 HP Two-speed Motor (208V)	
873J408	3 HP Two-speed Motor (208V)	
5	CB-504	Bearing

NOTE: For other motor parts or for replacement motor for Design Series "A" hoist (see Section 8-3), consult factory.

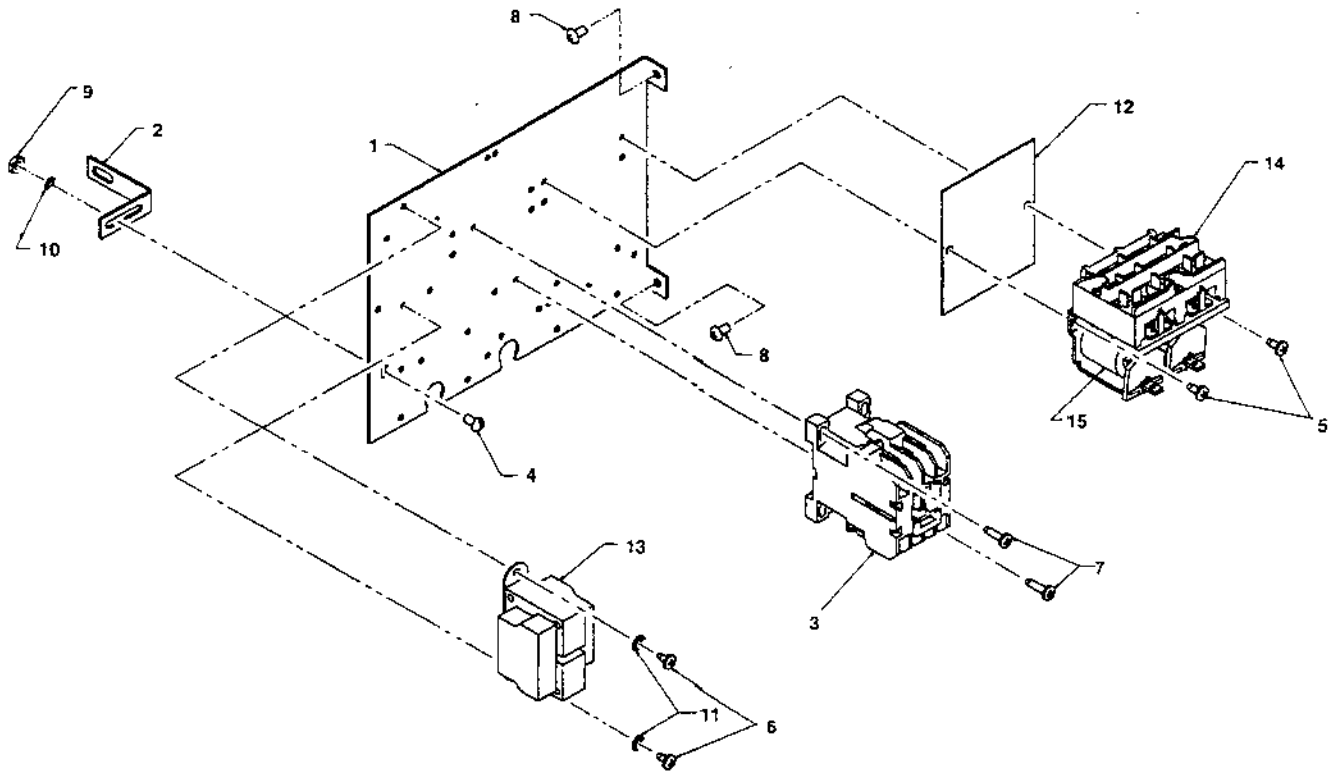
**FIGURE 8-4A. CONTROLLER AREA (SINGLE SPEED HOIST)**



Index No.	Part No.	Part Name
1	257J1B	Panel Plate
2	285J7	Panel Retainer
3	909K9	Terminal Block (9 Position)
4	H1009P	Screw (10-24 x .375 Long)
5	H2742P	Screw Thread Forming (8-32 x .375 Long)
6	H2751	Screw Thread Forming (8-32 x .3125 Long)
7	H2752	Screw Thread Forming (8-32 x .625 Long)
8	H2981-P	Screw Thread Forming (10-24 x .380)
9	H3862	Hex Nut (10-24 UNC-2A)
10	H4082P	#10 Lockwasher
11	H4158	#8 Lockwasher
12	JF759-3	Insulator
13		Transformer: (Single Speed)
	JL821-272	Pri.: 208V, Sec.: 24V
	JL821-271	Pri.: 208V, Sec.: 115V
	JL821-232	Pri.: 230/460V, Sec.: 24V
	JL821-231	Pri.: 230/460V, Sec.: 115V
	JL821-252	Pri.: 575V, Sec.: 24V
	JL821-251	Pri.: 575V, Sec.: 115V
14	JL829-24	MSD Contactor (24V)
	JL829-115	MSD Contactor (115V)
15	JF37916-25	Coil (24V)
	JF37916-32	Coil (115V)

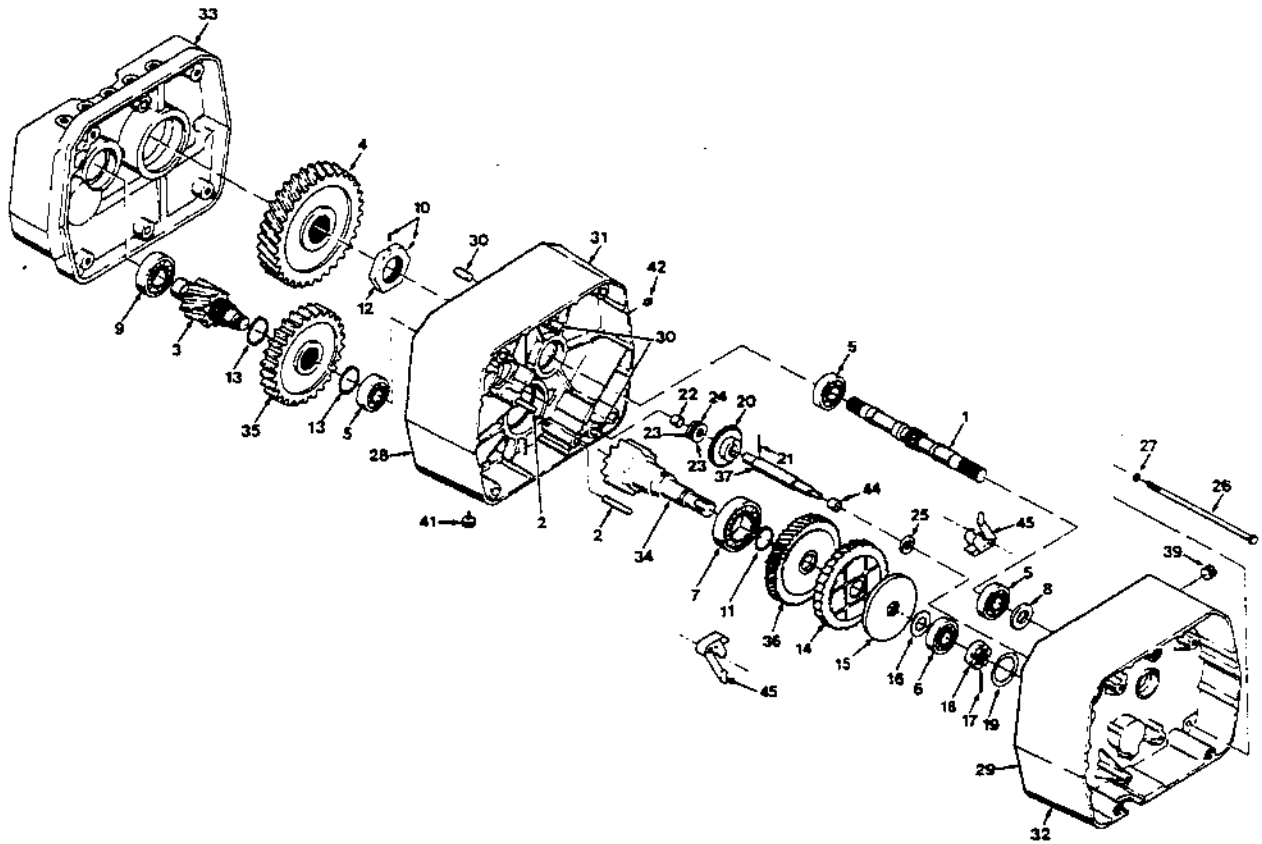


**FIGURE 8-4B. CONTROLLER AREA (TWO SPEED HOIST)**



Index No.	Part No.	Part Name
1	257J1B	Panel Plate
2	285J7	Panel Retainer
3	820J3	Speed Control Relay (24V)
	820J4	Speed Control Relay (115V)
4	H1009P	Screw (10-24 x .375 Long)
5	H2742P	Screw Thread Forming (8-32 x .375 Long)
6	H2751	Screw Thread Forming (8-32 x .3125 Long)
7	H2752	Screw Thread Forming (8-32 x .625 Long)
8	H2981-P	Screw Thread Forming (10-24 x .380)
9	H3862	Hex Nut (10-24 UNC-2A)
10	H4082P	#10 Lockwasher
11	H4158	#8 Lockwasher
12	JF759-3	Insulator
13		Transformer: (Two Speed)
	JL821-272	Pri.: 208V, Sec.: 24V
	JL821-271	Pri.: 208V, Sec.: 115V
	JL821-232	Pri.: 230V, Sec.: 24V
	JL821-231	Pri.: 230V, Sec.: 115V
	JL821-232	Pri.: 460V, Sec.: 24V
	JL821-231	Pri.: 460V, Sec.: 115V
	JL821-252	Pri.: 575V, Sec.: 24V
	JL821-251	Pri.: 575V, Sec.: 115V
14	JL829-24	MSD Contactor (24V)
	JL829-115	MSD Contactor (115V)
15	JF37916-25	Coil (24V)
	JF37916-32	Coil (115V)

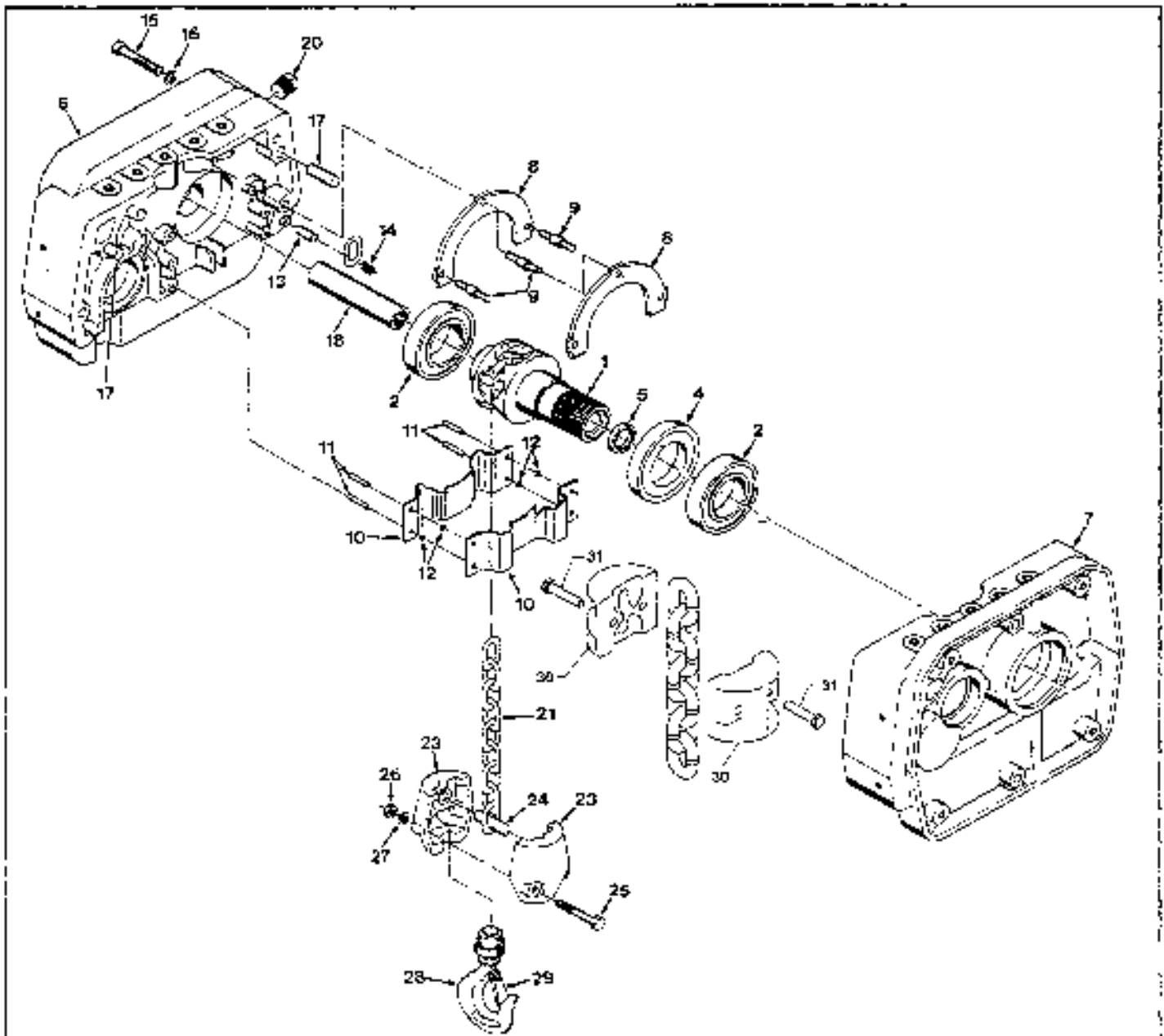
FIGURE 8-5. TRANSMISSION



Index No.	Part No.	Part Name
1	400J7	High Speed Pinion
2	H-5493	Dowel Pin
3	404J3	Output Pinion
4	405J1	Output Gear
5	500K13	Bearing
6	500K14	Bearing
7	500K15	Bearing
8	561K18	Seal
9	500K35	Bearing
10	H-2597	Setscrew
11	H-5539	Retaining Ring
12	130J7	Lock Nut
13	H-5540	Retaining Ring
14	7JG16-1	Ratchet Assembly
15	SJ9	Pressure Plate
16	255K11	Thrust Washer
17	H-5219	Driv-Lok Pin
18	130J8	Lock Nut (Load Brake)
19	H-7834	Spring Washer
20	428J1	Limit Switch Gear
21	H-5232	Spring Pin
22	530J24	Bushing
23	255J19	Thrust Washer
24	511J17	Thrust Bearing
25	561K17	Seal
26	H-2333	Bolt
27	H4157	Lock Washer
28	560K15	Transmission Adapter Gasket (Reference—See figure 8-1)
29	560J6	Transmission Cover Gasket (Reference—See figure 8-1)
30	H-5387	Dowel Pin

Index No.	Part No.	Part Name
31		Transmission Housing (Reference—See figure 8-1)
32		Transmission Cover (Reference—See figure 8-1)
33		Sheave Housing, Transmission Side (Reference—See figure 8-1)
34	402J6	Intermediate Pinion (Models EC4024, EC8012 & EC10008)
	402J7	Intermediate Pinion (Models EC4016, EC8008 & EC10005)
	402J8	Intermediate Pinion (Model EC6010)
	402J9	Intermediate Pinion (Models EC2032 & EC6016)
35	403K4	Intermediate Gear (Models EC4016, EC8008 & EC10005)
	403K5	Intermediate Gear (Models EC4024, EC8012 & EC10008)
	403J6	Intermediate Gear (Model EC6010)
	403J7	Intermediate Gear (Models EC2032 & EC6016)
36	591JG12	Load Equalizer Assembly (Models EC4024, EC6016 EC8012 & EC10008)
	591JG13	Load Equalizer Assembly (Models EC2032, EC4016, EC6010, EC8008 & EC10005)
37	140J1	Standard Limit Switch Drive Shaft
39	SK1912-21W	Relief Fitting
41	H-6268	Drain Plug
42	S-25-9	Level Plug
44	530J29	Bushing
45	25JG4-1	Pawl Assembly

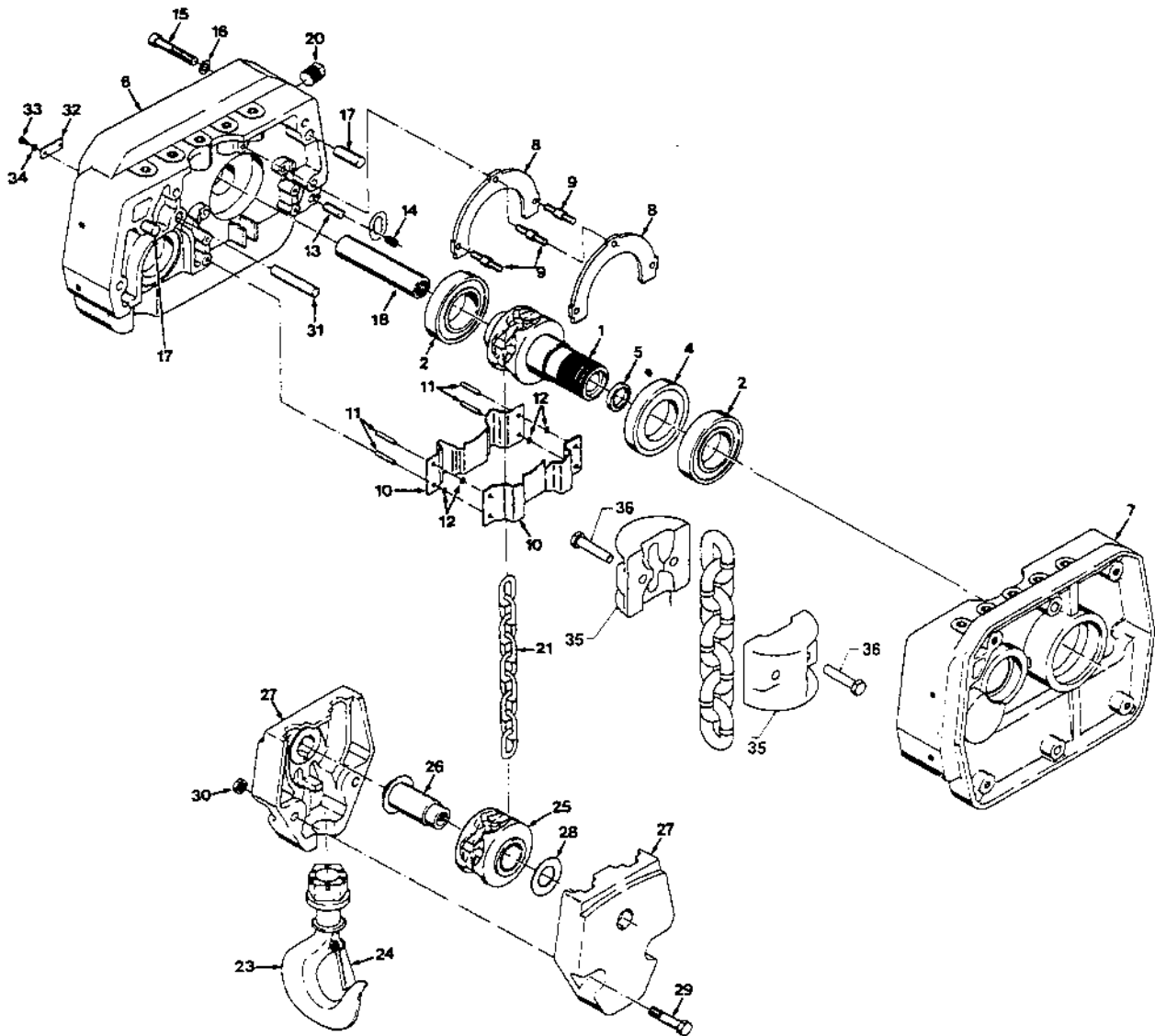
FIGURE 8-6A. CHAINING PARTS (SINGLE CHAIN)



Index No.	Part No.	Part Name
1	16J9	Load Sheave
2	500K12	Bearing
3	561K19	Seal
4	561K18	Seal
6		Sleeve Housing, Motor Side (Reference—See figure 8-1)
7		Sleeve Housing, Transmitting Side (Reference—See figure 8-1)
8	77316	Chain Guide Plate
9	12933	Chain Guide Plate Spacer
10	25413	Chain Guide
11	H-5396	Pin
12	X-6477-2S	"O" Ring
13	H-9455-P	Tail End Pin
14	2315	Spring
15	H-2219	Socket Head Cap Screw
16	H-4063-P	Lock Washer
17	H-5592	Dowel Pin

Index No.	Part No.	Part Name
18	107JG8-7	Drive Coupling
20	H-5786	Pipe Plug
21	1913	Load Chain (Standard)
	1973Z	Load Chain (Plated)
22	913JG2	Bottom Block Assembly (Consists of index nos. 23 thru 29)
23	3019	Load Block Frame
24	1817	Pin
25	S-44-33	Screw
26	H-4978	Nut
27	H-4157	Lock Washer
28	35G14S	Section Hook Assembly with Latch
29	H-7544	Latch Kit
30	7518	7/16" End Stop Frame
	H-2376	Screw
31	75JG8K	7/16" End Stop Kit (Contains index nos. 30 (2), 31 (2) and instruction sheet)

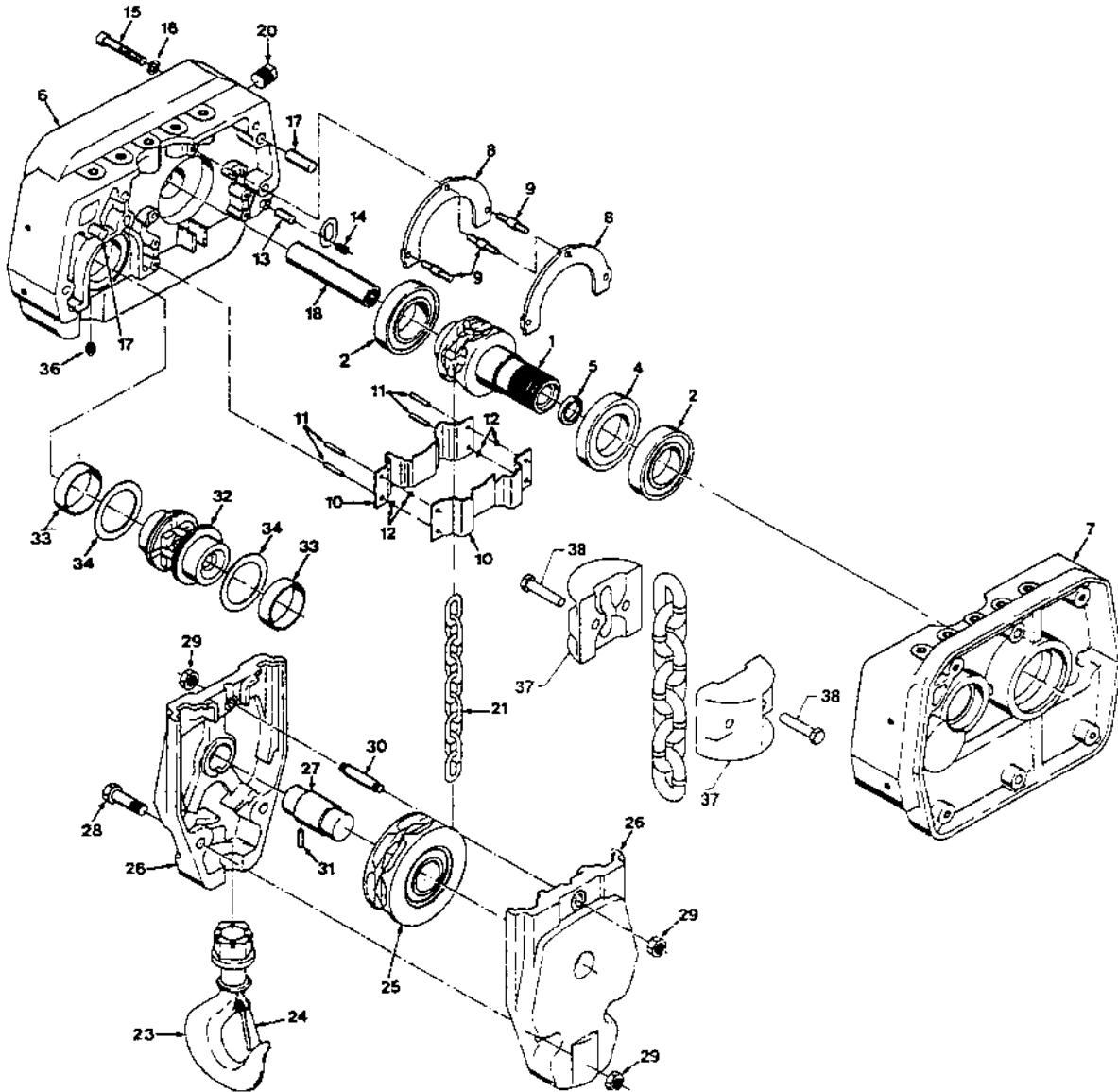
FIGURE 8-6B. CHAINING PARTS (DOUBLE CHAIN)



Index No.	Part No.	Part Name
1	16J9	Load Sheave
2	500K12	Bearing
4	561K19	Seal
5	561K18	Seal
6		Sheave Housing, Motor Side (Reference—See figure 8-1)
7		Sheave Housing, Transmission Side (Reference—See figure 8-1)
8	272J6	Chain Guide Plate
9	127J3	Chain Guide Plate Spacer
10	254J3	Chain Guide
11	H-5393	Pin
12	X-6477-39	"O" Ring
13	H-5495-P	Tail End Pin
14	23J5	Spring
15	H-2219	Socket Head Cap Screw
16	H-4063-P	Lock Washer
17	H-5392	Dowel Pin
18	107JG8-7	Drive Coupling
20	H-6286	Pipe Plug
21	19J3	Load Chain (Standard)
	19J3Z	Load Chain (Plated)

Index No.	Part No.	Part Name
22	914JG13	Bottom Block Assembly (For 3 Ton Hoist) (Consists of index nos. 23 thru 30)
	914JG14	Bottom Block Assembly (For 4 Ton Hoists) (Consists of index nos. 23 thru 30)
23	3JG8S	Bottom Hook Assembly With Latch
24	H-7545	Latch Kit
25	28JG5	Chain Sprocket Assembly
26	122JG6	Sheave Pin Assembly
27	30J10	Load Block Frame (For 3 Ton Hoists)
	30J11	Load Block Frame (For 4 Ton Hoists)
28	255J24	Sheave Washer
29	H-2419-P	Hcx Head Cap Screw
30	H-3966-P	Hex Nut
31	18J5	Dead End Pin
32	285J6	Dead End Pin Retainer
33	H-1009-P	Screw
34	H-4082-P	Lock Washer
35	75J8	7/16" End Stop Frame
36	H-2376	Screw
*	75JG8K	7/16" End Stop Kit (Contains index nos. 35 (2), 36 (2) and instruction sheet)

FIGURE 8-6C. CHAINING PARTS (TRIPLE CHAIN)

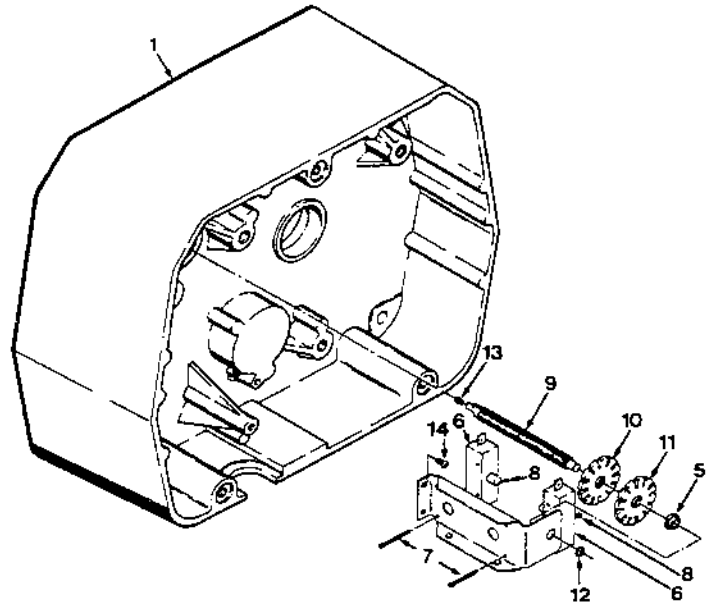


Index No.	Part No.	Part Name
1	16J9	Load Sheave
2	500K12	Bearing
4	561K19	Seal
5	561K18	Seal
6		Sheave Housing, Motor Side (Reference—See figure 8-1)
7		Sheave Housing, Transmission Side (Reference—See figure 8-1)
8	272J6	Chain Guide Plate
9	127J3	Chain Guide Plate Spacer
10	254J3	Chain Guide
11	H-5393	Pin
12	X-6477-39	"O" Ring
13	H-5495-P	Tail End Pin
14	23J5	Spring
15	H-2219	Socket Head Cap Screw
16	H-4063-P	Lock Washer
17	H-5392	Dowel Pin
18	107JG8-7	Drive Coupling
20	H-6286	Pipe Plug
21	19J3	Load Chain (Standard)

Index No.	Part No.	Part Name
22	19J3Z	Load Chain (Plated)
	914JG12	Bottom Block Assembly (Consists of index nos. 23 thru 31)
23	CB-912-14	Bottom Hook Assembly With Latch
24	H-7545	Latch Kit
25	28JG6	Chain Sprocket Assembly
26	30J12	Load Block Frame
27	122J7	Sheave Pin
28	H-2419-P	Hex Head Cap Screw
29	H-3966-P	Hex Nut
30	18J6	Dead End Pin
31	H-5210	Driv-Lok Pin
32	28J4	Idler Sheave
33	550J10	Idler Sheave Bushing
34	255J23	Thrust Washer
36	SK-974-32	Grease Fitting
37	75J8	7/16" End Stop Frame
38	H-2376	Screw
*	75JG8K	7/16" End Stop Kit (Contains index nos. 37 (2), 38 (2) and instruction sheet)

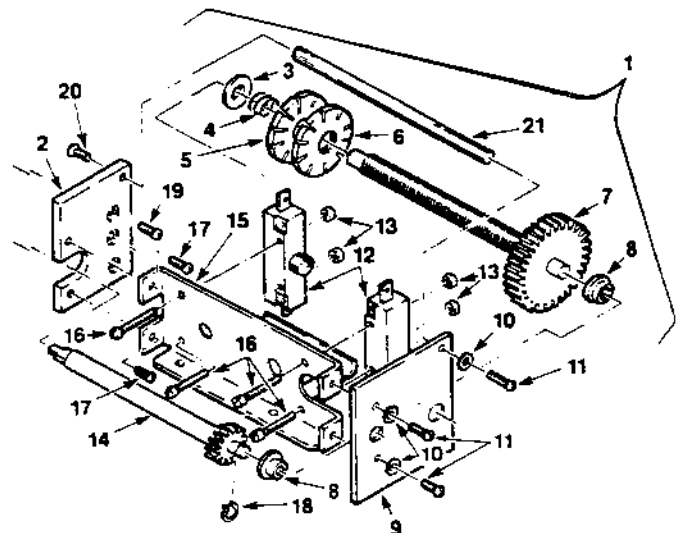
**FIGURE 8-7A. STANDARD LIMIT SWITCH PARTS  
USED ON STANDARD LIFT HOISTS**

Index No.	Part No.	Part Name
1		Transmission Cover (Reference—See figure 8-1)
2	918JG4	Limit Switch and Shaft Assembly (Consists of index nos. 3 thru 12)
3	918JG3	Limit Switch Assembly (Consists of index nos. 4 thru 8)
4	JF-900-3	Limit Switch Bracket Assembly (Includes index no. 5)
5	JF-531-4	Limit Switch Bushing
6	815J1	Microswitch, Limit
7	H-1402-P	Screw
8	H-3944	Nut
9	JF-117-3S	Limit Switch Shaft (Stainless Steel)
10	SK6000-63Z	Limit Switch Nut (Zinc/Silver)
11	SK6000-63W	Limit Switch Nut (Brass/Gold)
12	H-5520	Retaining Ring
13	JF-343-3	Spring
14	H-2981-P	Screw

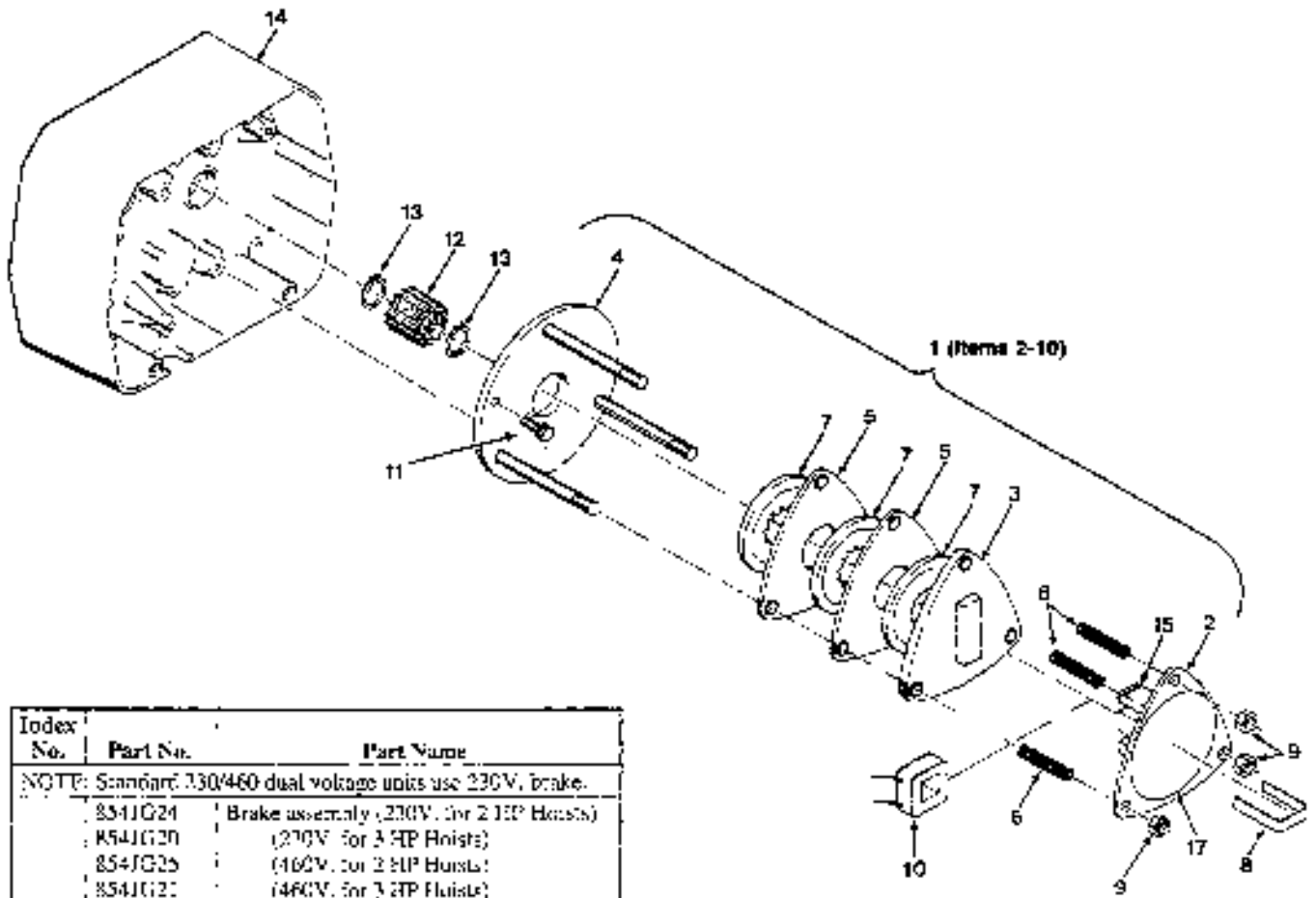


**FIGURE 8-7B. GEARED LIMIT SWITCH PARTS  
USED ON LONG LIFT HOISTS**

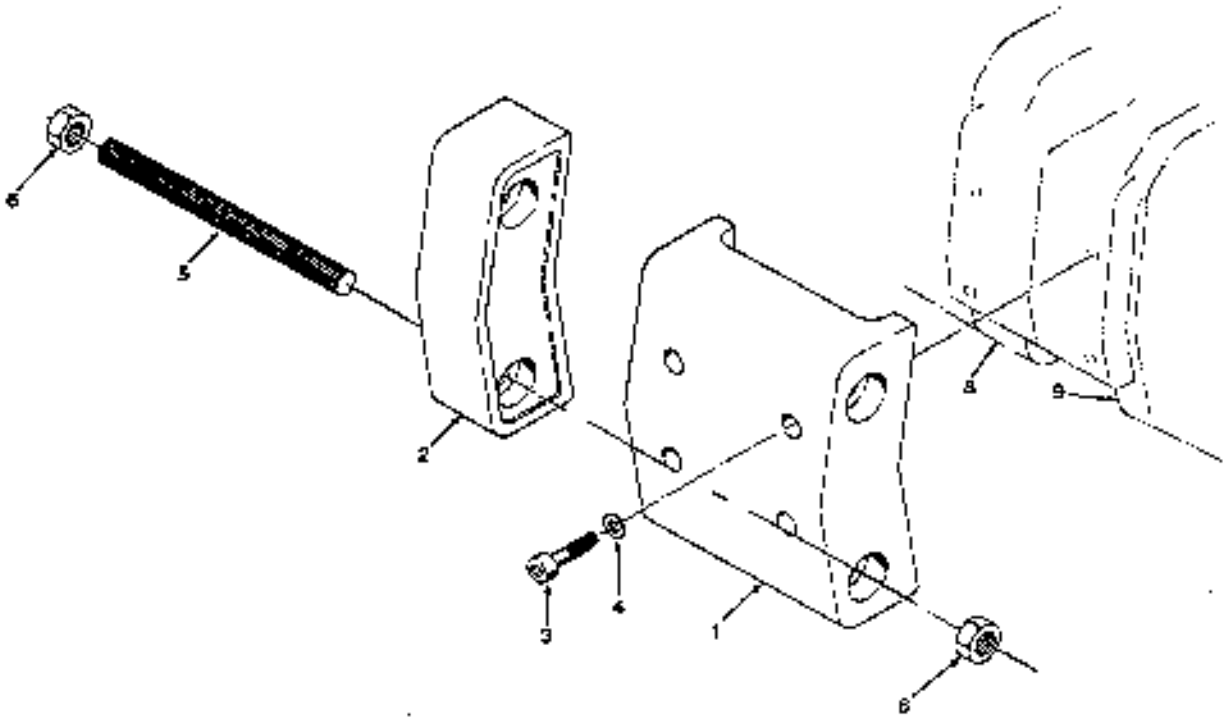
Index No.	Part No.	Part Name
1	944JG6	Long Lift Limit Switch Assembly (all items except No. 19)
2	129J1	Mounting Plate
3	255K16	Thrust Washer
4	PB-287	Spring
5	SK6000-63Z	Limit Switch Nut (Zinc/Silver)
6	SK6000-63W	Limit Switch Nut (Brass/Gold)
7	117JG2	Shaft and Gear Assembly
8	JF-531-4	Bushing
9	258J8	End Plate
10	H-4158	Lock Washer
11	H-2741-P	Screw
12	815J1	Switch
13	H-3944	Locknut
14	427J1	Drive Pinion
15	258JG7	Frame and Guide Assembly
16	H-1402-P	Screw
17	854823	Screw
18	H-5520	Retaining Ring
19	H-2981-P	Mounting Screw
20	H-1210	Flat Head Screw
21	110J14	Post



**FIGURE 8-8. MOTOR BRAKE PARTS**



Index No.	Part No.	Part Name
NOTE: Standard 330/460 dual voltage units use 230V. brake.		
	854JG24	Brake assembly (230V. for 2 HP Hoists)
	854JG20	(270V. for 3 HP Hoists)
	854JG25	(460V. for 2 HP Hoists)
	854JG21	(460V. for 3 HP Hoists)
	854JG26	(575V. for 2 HP Hoists)
	854JG22	(575V. for 3 HP Hoists)
	854JG27	(208V. for 2 HP Hoists)
	854JG25	(208V. for 3 HP Hoists)
2	291JK8	Plate and Frame Assembly
3	291JG9	Plate and Armature Assembly
4	290JG4	Plate and Stud Assembly
5	291J10	Plate
6	344J4	Spring
7	581JG2	Brake Disc Assembly
8	JF-710	Retainer
9	H-3976	Lock Nut
10	JF-853-2	Coil (330V. 60 Hz)
	JF-853-3	Coil (460V. 60 Hz)
	JF-853-4	Coil (575V. 60 Hz)
	JF-853-5	Coil (208V. 60 Hz)
11	H-2988-1'	Screw
12	142J7	Brake Adapter
13	H-5527	Retaining Ring
14		Transmission Cover
		(Reference—See figure 8-1)
15	86G11	Shading Coil Element (Must be attached to frame with H-7812 adhesive.)
16	H-7812	Adhesive (1/2" tube)
17	976J1	Discal
18	H-1063-1'	Lock Washer

**FIGURE 8-9. COUNTERWEIGHTS**

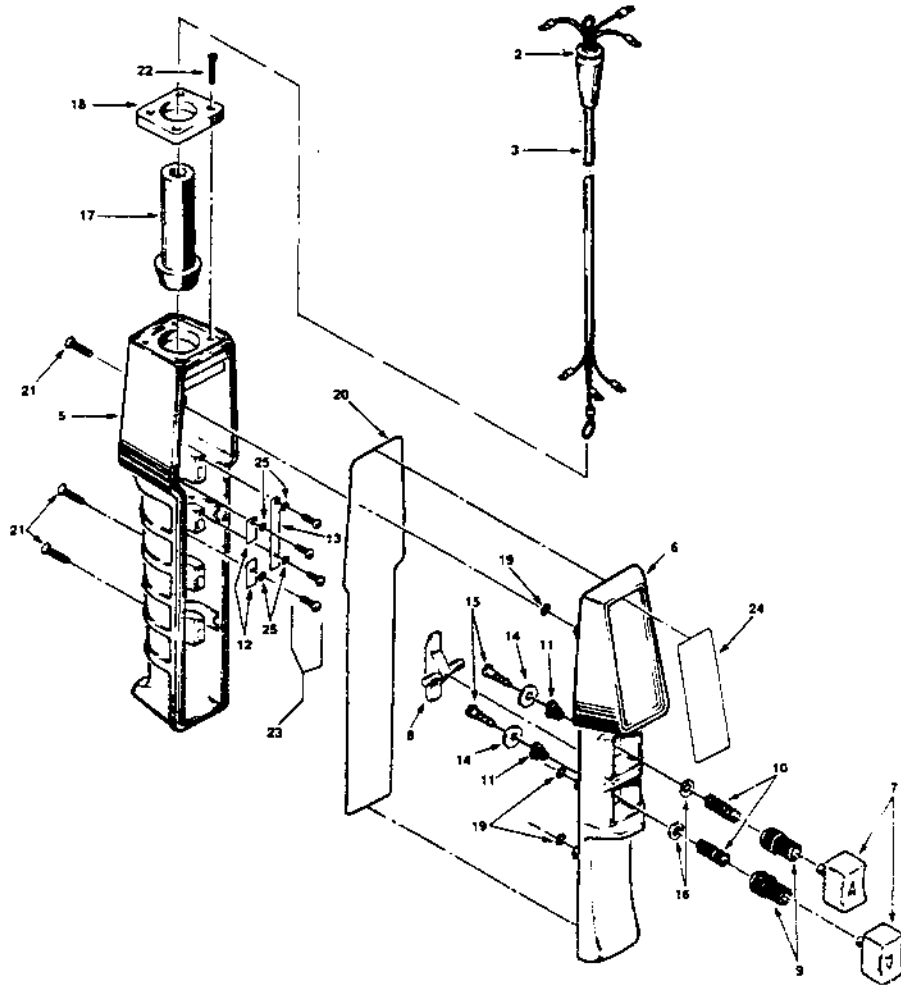
Index		
No.	Part No.	Part Name
1	5373	Counterweight (40 Lbs.)
2	5372	Counterweight (70 Lbs.)
3	S-49 22	Socket Head Cap Screw
4	E-4157	Lock Washer
5		Pin, Threaded
6	11 3947	Nut
8		Sheave Housing, Motor Side (Reference—See Figure 8-1)
9		Sheave Housing, Transmission Side (Reference—See Figure 8-1)
10*	12951	Counterweight Kit (40 Lbs.)
11*	12952	Counterweight Kit (60 Lbs.)
12*	12953	Counterweight Kit (80 Lbs.)
13*	12954	Counterweight Kit (100 Lbs.)
14*	12955	Counterweight Kit (120 Lbs.)
15*	12956	Counterweight Kit (140 Lbs.)
16*	12957	Counterweight Kit (160 Lbs.)
17*	12958	Counterweight Kit (180 Lbs.)
18*	12959	Counterweight Kit (200 Lbs.)
19*	12960	Counterweight Kit (220 Lbs.)

\* Not shown

Kits include counterweights, threaded pins and hardware.



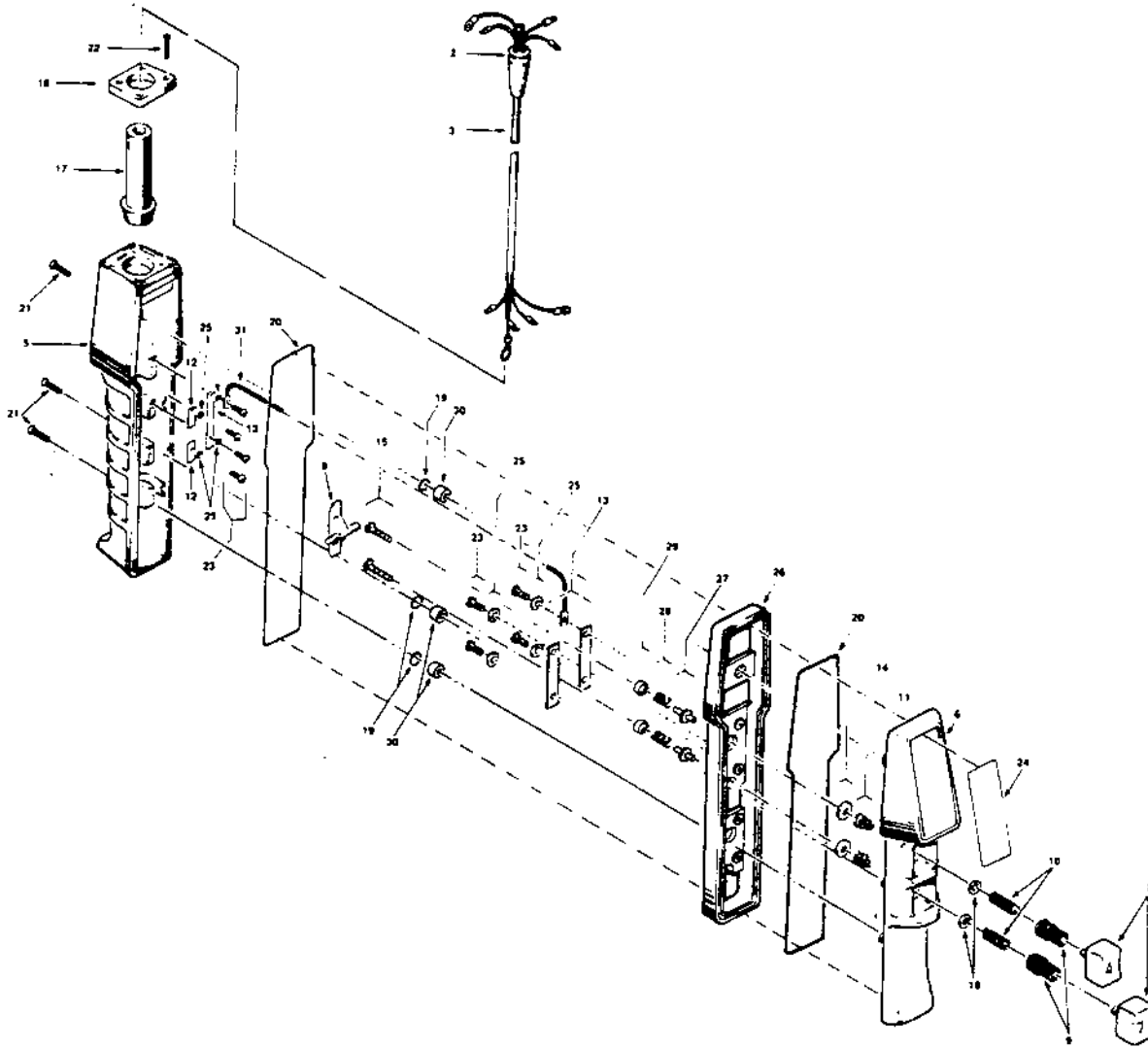
**FIGURE 8-10A. PUSHBUTTON (SINGLE SPEED HOISTS)**



Index No.	Part No.	Part Name
1		Pushbutton & Cable Assembly (Consists of index nos. 2 thru 25)
	PB-299-6B	6 ft. Cable Length
	PB-299-11B	11 ft. Cable Length
	PB-299-16B	16 ft. Cable Length
	PBS-299-*B	Special Drop (*Equal to P. B. Drop)
2	JF-761	Rubber Grommet
3		Pushbutton Cable Assembly:
	PB-299-6	6 ft. Cable Length
	PB-299-11	11 ft. Cable Length
	PB-299-16	16 ft. Cable Length
	PBS-299-*	Special Drop (*Equal to P.B. Drop)
4	534K97B	Pushbutton Assembly (Consists of index nos. 5 thru 25)
5	PB-282-4	Enclosure

Index No.	Part No.	Part Name
6	PB-298	Cover
7	PB-284-2	Pushbutton
8	PB-285	Interlock (Single Speed. Red)
9	PE-286	Boot
10	PB-287	Spring, Compression
11	PB-288	Spring, Conical
12	PB-289	Contact Plate
13	PB-290	Contact Plate, Common
14	PB-291	Washer, Contact
15	PB-301	Screw
16	PB-293	Washer, Boot
17	PB-294-1	Grommet
18	PB-295	Cap. Enclosure
19	X-6477-1	"O" Ring
20	H-7851	Rubber Seal
21	H-2991	Screw
22	H-2992	Screw
23	H-2993	Screw
24	PB-296	Warning Tag
25	H-4160	Lock Washer

**FIGURE 8-10B. PUSHBUTTON (TWO SPEED HOISTS)**



Index No.	Part No.	Part Name
		Pushbutton & Cable Assembly (Consists of index nos. 2 thru 30)
	534JG4-6	6 ft. Cable Length
	534JG4-11	11 ft. Cable Length
	534JG4-16	16 ft. Cable Length
	534JG4-*	special Drop (*Equal to P.B. Drop)
2	JF-761	Rubber Grommet
3		Pushbutton Cable Assembly:
	PB-300-6	6 ft. Cable Length
	PB-300-11	11 ft. Cable Length
	PB-300-16	16 ft. Cable Length
	PBS-300-*	Special Drop (* Equal to P.B. Drop)
4	534JG4	Pushbutton Assembly (Consists of index nos. 5 thru 31)
5	PB-282-4	Enclosure
6	PB-298	Cover
7	PB-284-2	Pushbutton
8	PB-285-1	Interlock (Two-Speed. Black)

Index No.	Part No.	Part Name
9	PB-286	Boot
10	PB-287	Spring, Compression
11	PB-288	Spring, Conical
12	PB-289	Contact Plate
13	PB-290	Contact Plate, Common
14	PB-291	Washer, Contact
15	H- 1 852-P	Screw
16	PB-293	Washer, Boot
17	PB-294-2	Grommet
18	PB-295	Cap, Enclosure
19	X-6477-1	"O" Ring
20	H-7851	Rubber Seal
21	H-2925	Screw (Enclosure)
22	H-2992	Screw (Cap)
23	H-2993	Screw (Plates)
24	PB-296	Warning Tag
25	H-4160	Lock Washer
26	PB-308	2-Speed Adapter
27	755J1	Insulating Bushing
28	344J5	Spring, Lower
29	201J1	Contact Button
30	200J16	Bushing
31	JF-940-42	Jumper Wire

# COFFING<sup>®</sup>

## HOISTS

### WARRANTY

**E**very hoist is thoroughly inspected and tested prior to shipment from the factory. Should any problem develop, return the complete hoist prepaid to your nearest Coffing Hoists Authorized Warranty Repair Station. If inspection reveals that the problem is caused by defective workmanship or material, repairs will be made without charge and the hoist will be returned, transportation prepaid. This warranty does not apply where: (1) deterioration is caused by normal wear, abuse, improper or inadequate power supply, eccentric or side loading, overloading, chemical or abrasive actions, improper maintenance, or excessive heat; (2) problems resulted from repairs

modifications, or alterations made by persons other than factory or Coffing Authorized Warranty Repair Stations personnel; (3) the hoist has been abused or damaged as a result of an accident; (4) repair parts or accessories other than those supplied by Coffing Hoists are used on the hoist. Equipment and accessories not of the seller's manufacture are warranted by the manufacturer.

**Except as stated herein, Coffing Hoists makes no other warranties, express or implied, including warranties of merchantability and fitness for a particular purpose.**

### WARNING

**Overloading and Improper Use Can Result In Injury**

**To Avoid Injury:**

- Do not exceed working load limit, load rating, or capacity.
- Do not use to lift people or loads over people.
- Use only alloy chain and attachments for overhead lifting.
- Read and follow all instructions.

**Coffing Hoists • Country Club Road • P.O. Box 779 • Wadesboro, NC 28170 USA**  
**Customer Service: Tel. (800) 477-5003 (704) 694-2156 • FAX (800) 374-6853 (704) 694-6829**

FCO-480-9  
 40-100  
 Printed in USA  
 © 2000 Coffing Hoists