



# Laser Guard

---

Laser Anti-Collision System

---

## Instruction Manual



**MAGNETEK**  
MATERIAL HANDLING  
**TELEMOTIVE**

TC14K-0 Rev. I    October 2009

Part Number: 21316T

©Copyright 2009 Magnetek Material Handling

This page intentionally left blank.

# Table of Contents

<a href="#">Section 1 – Service Information</a>	1
<a href="#">1-1. Service Information</a>	1
<a href="#">Section 2 – Crane Safety</a>	3
<a href="#">2-1. Introduction</a>	3
<a href="#">2-2. General</a>	3
<a href="#">2-3. Persons Authorized To Operate Cranes</a>	3
<a href="#">2-4. Training Checklist For Crane Operators</a>	3
<a href="#">2-5. Operating Area</a>	3
<a href="#">2-6. Anti-collision Unit</a>	3
<a href="#">2-7. Operating The Crane</a>	4
<a href="#">2-8. Boarding The Crane</a>	4
<a href="#">2-9. Crane Repair</a>	5
<a href="#">2-10. Using The Crane As A Work Platform</a>	5
<a href="#">2-11. Condition Of The Crane</a>	6
<a href="#">Section 3 – General System Information</a>	7
<a href="#">3-1. Class 1 Laser Device</a>	7
<a href="#">3-2. Laser Anti-Collision System Description</a>	7
<a href="#">3-3. Optical Path Fault Detector</a>	7
<a href="#">3-4. Fault Relay</a>	7
<a href="#">3-5. Specifications</a>	8
<a href="#">Section 4 – Installation Information</a>	9
<a href="#">4-1. Mounting Location Considerations</a>	9
<a href="#">4-2. Line Input Considerations</a>	9
<a href="#">4-3. Wiring Considerations</a>	9
<a href="#">4-4. Mechanical Installation</a>	9
<a href="#">4-5. Electrical Installation</a>	10
<a href="#">4-6. Mechanical Alignment</a>	10
<a href="#">4-7. Range Detector Settings (Static Method)</a>	11
<a href="#">4-8. Optical Path Fault Detector Checkout</a>	11
<a href="#">4-9. Trouble Shooting</a>	11
<a href="#">Table 4-1. Range versus Test Point Voltage</a>	13
<a href="#">Table 4-2. Laser Diagnostic LED Functions</a>	14
<a href="#">Section 5 - Laser Guard Replacement Parts List</a>	15
<a href="#">Section 6 – Installation Diagrams</a>	16
<a href="#">Figure 6-1. Laser and Target Installation</a>	16
<a href="#">Figure 6-2. Conduit Installation</a>	17
<a href="#">Figure 6-3. Laser Support Unit E14008-0 Board Wiring (110 VAC and 240 VAC Unit)</a>	18
<a href="#">Figure 6-4. Laser Support Unit E14001-0 Board Wiring (110 VAC Unit)</a>	19
<a href="#">Figure 6-5. Laser Support Unit E14008-0 and E14001-0 Board Wiring (250 VDC Unit)</a>	20
<a href="#">Figure 6-6A. Laser Support Unit E14008-0 and E14001-0 Board Wiring (8-30 VDC Unit)</a>	21
<a href="#">Figure 6-6B. Laser Support Unit E14008-0 and E14001-0 Board Alt. Wiring (10-40 VDC Unit)</a>	22
<a href="#">Figure 6-7. Laser Connector Wiring Diagram</a>	23
<a href="#">Figure 6-8. Laser Optical Unit and Mounting Assembly</a>	24
<a href="#">Figure 6-9. Template for Laser Base Mounting Holes</a>	25
<a href="#">Figure 6-10. Template for Laser Optical Mounting Holes</a>	26
<a href="#">Figure 6-11. Target Dimensions</a>	27
<a href="#">Figure 6-12. Enclosure Dimensions</a>	28
<a href="#">Figure 6-13. Test Point Locations</a>	29
<a href="#">Figure 6-14. Laser Guard Crane Magnetic Control, Protection in One Direction</a>	30
<a href="#">Figure 6-15. Laser Guard Crane Control with Timed Bypass, Protection in One Direction</a>	31
<a href="#">Figure 6-16. Laser Guard Stepped VFD or Magnetic Crane Control, Protection in Both Directions</a>	32
<a href="#">Figure 6-17. Laser Guard Stepped VFD or Magnetic Crane Control, Protection in One Direction</a>	33
<a href="#">Figure 6-18. Typical Laser Guard Interface with Stepless VFD Control</a>	34
<a href="#">Figure 6-19. Typical Laser Guard Interface with P&amp;H Stepless VFD Control</a>	35

This page intentionally left blank

# **Section 1 – Service Information**

## **1-1. Service Information.**

### **U.S. Service Information**

For questions regarding service or technical information contact:

**1-866-MAG-SERV  
(1-866-624-7378).**

Magnetek Material Handling  
N49 W13650 Campbell Drive  
Menomonee Falls, WI 53051

**Telephone:** 800-288-8178

**Website:** [www.magnetekmh.com](http://www.magnetekmh.com)  
**e-mail:** [info@magnetekmh.com](mailto:info@magnetekmh.com)

#### **Fax Numbers:**

*Main:* 800-298-3503  
*Sales:* 262-783-3510  
*Service:* 262-783-3508

#### **Canada Service Information:**

2610 Dunwin Drive  
Mississauga, Ontario  
L5L 1J5 Canada  
Phone: 1-800-792-7253  
Fax: 1-905-828-5707

This page intentionally left blank.

## **Section 2 - Crane Safety**

### **2-1. Introduction.**

The safety rules in this section are not intended to replace any rules or regulations or any applicable local, state, or federal governing organizations. The following information is intended to be used in conjunction with other rules or regulations already in existence. It is important to read all of the safety information contained in this section before operating the Radio Control System.

### **2-2. General.**

Overhead cranes and other material handling equipment operate in several directions. They are large, bulky pieces of equipment that handle heavy loads efficiently at high speeds. Quite frequently, the equipment is operated in areas where people are working on the floor below. The crane operator must exercise extreme caution at all times. Workers must constantly be alert to avoid accidents. The following rules have been included to indicate how your careful and thoughtful actions may prevent injuries, damage to equipment, or even save a life. If radio controlled material-handling equipment is operated from the cab, special care must be taken to secure the transmitter. Refer to paragraph titled "[Boarding The Crane](#)" for specific safety rules.

### **2-3. Persons Authorized To Operate Cranes.**

Only properly trained persons designated by management should be permitted to operate cranes.

Any person who cannot read or understand signs, notices and operating instructions that pertain to the crane should not operate Cranes.

Cranes should not be operated by any person with insufficient eyesight or hearing or by any person who may be suffering from a disorder or illness or is taking any medication that may cause loss of crane control.

### **2-4. Training Checklist For Crane Operators.**

Anyone being trained to operate a radio-controlled crane should possess the following knowledge and skills before operating the crane:

Knowledge of hazards peculiar to crane operation.

Knowledge of safety rules for cranes.

Ability to judge distance or moving objects.

Knowledge of the crane control device.

Limit switch and anti-collision test procedure.

Where authorized, instructions for plugging motions.

Observing crane signal lights.

Avoid striking any obstructions.

Proper clearance of lifts or hooks before moving bridge or trolley.

Transferring crane control to another person.

Reporting unsafe or unusual operating conditions.

Caution in approaching bridge or trolley bumpers.

Equipment capacity.

Making lifts below floor level.

Making side pulls.

Keeping body clear of lifts and avoiding "pinch" points.

Cable and hook inspection.

Procedures for testing hoist, trolley, and bridge brakes.

### **2-5. Operating Area.**

Aisles between equipment, stock, etc., should be free of obstructions so the crane operator can move freely. These aisles should be a minimum of 3 feet wide, or meet local regulations.

Crane operators should always position themselves for the best view of the crane they are controlling. The crane should never be operated blindly. The operator should stay as close to the crane load as possible. Operators should never position themselves in a "pinch" point.

### **2-6. Anti-collision Unit**

Range detector relays should never be electrically or mechanically disabled to be ON or OFF for any crane motion. If the unit is for any reason disengaged or turned off the crane operating personnel must be notified immediately and proper alternate operation precautions taken.

## ***Section 2 - Crane Safety (Continued)***

### **2-7. Operating The Crane.**

The crane anti-collision unit and limit switches if any should be checked at the beginning of each shift or when a new operator takes control of the crane. When checking anti-collision unit and limit switches the hoist should be centered over an area free of personnel and equipment.

The anti-collision unit and limit switches should never be used as a regular stopping device. They are intended to be protective devices.

The bridge and trolley brakes should be tested at the beginning of each shift or when a new operator takes control of the crane. On cranes so equipped with two or more speeds, use the "lowest" speed when testing braking devices.

When lifting maximum loads, the crane operator should test the hoist brakes by raising the load a few inches from the floor. If the brakes do not hold, the load should immediately be lowered to the floor and a report made to the supervisor.

Do not make lifts in excess of the equipment rated capacity.

The bridge and trolley should be centered directly over the load when the load is raised to prevent swinging when making lifts.

Side pulls should be made by a crane designed for this purpose and only with supervisor permission. When a lift is being made, the crane operator should not be positioned in the line of travel. The crane or hoist should be operated from a position either to the side or opposite from the direction of travel.

When raising or lowering a load, proceed slowly and make certain the load is under control. Tag lines should be used for handling unusual lengths or bulky loads. Remove slack from chains or slings gradually. Make certain all personnel are clear before making a lift.

The crane operator should keep all body parts away from the lift and should never be positioned under the lift.

Do not make a lift or move a load if anyone is in a location where they could be struck by the crane or the load.

If the crane operator is being helped, the crane should not be moved until the helper signals they are clear of the crane and its load.

When a load is hanging from the crane hook and the crane is being moved, the crane operator should sound all warning devices frequently.

Loads should not be carried over workers heads. If a worker is in the path of crane travel, the crane operator should stop the crane and clear the area before proceeding.

Runway stops or other cranes should never be bumped into.

When moving the crane, the crane operator should be sure that the hook block and attachments or cables would not catch on nearby equipment. Slings, chains, or cables should never be dragged along the floor.

Unless required for operator safety, gloves should not be worn when operating the transmitter unit.

All loose materials or parts should be removed from the load before starting the lift.

The crane operator should always hoist lifts high enough to clear all equipment and workers.

The crane operator should never permit anyone to ride on the load or hook except when authorized by the supervisor.

When another crane on the same runway is stationary with a load hanging, the crane operator should maintain a safe distance between the stationary crane and the one under their control.

If power to the crane is removed, the crane operator should turn the transmitter unit OFF and keep it OFF until power is restored.

If the crane fails to respond properly, the crane operator should stop operation, turn the transmitter unit OFF and immediately report the condition to their supervisor.

Outdoor cranes, which are subject to movement by wind, should be securely anchored when left unattended. If the crane is equipped with bridge brakes, the parking brake should be set immediately.



## ***Section 2 - Crane Safety (Continued)***

### **2-8. Boarding The Crane.**

The crane should not be boarded without permission of the supervisor.

The crane operator should turn off the transmitter and take it with them when boarding the crane.

If more than one person is boarding the crane, one person should be made responsible for ensuring all personnel are off the crane before the system is returned to operation.

### **2-9. Crane Repair.**

Minor repairs include routine maintenance and repairs such as greasing, cleaning and control troubleshooting. All other repairs should be considered major. If the repair crew consists of more than one person, one person should be designated as the repair crew leader with the following responsibilities. If the repair crew consists of only one person, that person has the following responsibilities:

Warning signs should be placed on the floor beneath the crane or suspended from the crane. For major repairs, the floor area below the crane should be roped off.

When major repairs are to take place, all persons operating other cranes on the same or adjacent runways, if any, must be notified prior to starting repairs. Notification should include the nature of the repair, safeguards provided, and movement limitations while repairs are in progress.

When practical, radio controlled cranes which cannot be moved during repairs must be protected against being bumped by other cranes on the runway. Bumpers should be installed on the exposed side or sides of the crane under repair. They should be placed as far away as possible. The location of these bumpers should be indicated by red lights placed so that they are clearly visible to other crane operators traveling on the same runway. When it is not possible to use bumpers, red lights must be placed so they are clearly visible to other crane operators traveling on the same runway to indicate the restricted travel zone. All crane operators on the same runway must be informed of the repair effort and thoroughly instructed to what their operations are limited to and informed they will be notified when repairs are completed.

If any hazard involving the repairmen exists when there is a runway adjacent to the crane under repair, the adjacent runway should be blocked off as described above. When it is necessary to continue crane operation on the adjacent runways warning lights must be installed and be visible to operators of cranes on those runways. All cranes should come to a complete stop prior to entering the restricted area and should proceed through this area only after receiving permission from a signal person designated for this purpose. Access of persons to and from the crane being repaired should be under control of the repair crew leader.

When boarding the crane, the transmitter should be turned OFF and the transmitter should remain with the repair crew leader. The leader should board the crane first, open and lock out the main switch, and then signal the other members of the crew it is safe to board the crane.

If work on the crane is to be done in areas not protected by standard handrails, the repair crew should wear approved safety belts.

All tools and equipment should be moved onto the crane by the use of hand lines. The tools and equipment should be adequately secured to the hand lines.

If it is necessary to have the crane control circuits energized, all power circuits for crane movement must be opened prior to energizing the control circuits.

All personnel and tools should be moved to a safe spot before moving the crane during repairs.

Headroom is at a minimum in some crane cabs and on some crane walkways. Caution should be exercised when boarding or working on cranes. Hard hats should be worn whenever possible.

When repairs are finished, all personnel, tools and repair equipment should be removed before energizing the crane circuits.

### **2-10. Using The Crane As A Work Platform.**

When the crane is to be used as a stationary work platform, follow all rules provided in "[Crane Repair](#)" section.

When it is necessary for the crane to be moved from time to time, the crane operator should board the

## ***Section 2 - Crane Safety (Continued)***

crane with the transmitter unit. The crane operator should ensure all personnel working on the crane are in a secure position before moving the crane to the next workstation. It should also be the crane operators responsibility to ensure the main switch is open and locked down before work is resumed.

Condition of warning or signal lights (burned out or broken).

### **WARNING**

THE CRANE OPERATOR SHOULD NOT ATTEMPT TO MAKE ANY OF THE REPAIRS STATED BELOW. THE CRANE CONDITION SHOULD BE REPORTED TO THE SUPERVISOR.

#### **2-11. Condition Of The Crane.**

If the crane fails to respond properly, the crane operator should notify their supervisor. When serious conditions are noticed (conditions that make the crane unsafe to operate), the crane should be shut down immediately and the supervisor notified. The following is a list of what should be included in the report:

Condition of hoisting cable and hook block

(broken strands, clipped sheave wheels, etc.).

Condition of brakes (hoist, trolley, and bridge).

Alignment of bridge (screeching or squealing wheels indicate bridge is out of line).

Broken, cracked, or chipped rails on trolley or runway.

Condition of limit switches.

Condition of electrical and mechanical control (electrical or mechanical defects which cause faulty operation such as un-commanded stopping or starting of any crane motions, warning devices, lights, or auxiliary functions).

Condition of gears (grinding or squealing may indicate foreign materials in gear teeth or a lack of lubrication).

Frequent relay tripping of power circuits.

Mechanical parts loosened by vibration (loose rivets, covers, bolts, etc.).

Uneven riding (worn wheels).

Condition of collector shoes or bars.

## **Section 3 – General System Information**

### **3-1. Class 1 Laser Device**

The Telemotive Anti-Collision System contains a Class 1 laser because of this no special protection on the part of the installer or user is needed. However, it is recommended that no one look directly into the laser with their eye close to the lens of the laser unit. Do not open the laser unit to service it since there are no serviceable parts inside.

### **3-2. Laser Anti-Collision System Description**

Telemotive's Anti-Collision System measures the distance between the laser unit's lens and its companion retro-reflective target by means of pulse timing techniques that allow for very accurate measurements. The laser communicates with the range detector module by means of a 4 mA to 20 mA current loop. This type of communications link has very high noise immunity and provides the necessary accuracy for a collision avoidance system. The laser used in the Laser Guard system is set to measure distances from 5 ft. to 150 ft. with an output current of 4 mA at 5 ft. and 20 mA at 150 ft. Should a fault occur within the laser unit, the output will drop to 0 ma. The laser unit uses a modified light beam making system alignment very easy. On the back of the laser are two LEDs. The red LED indicates a laser self-check when power is first applied, and a laser failure if it stays on. The green LED displays laser received signal strength and is used for alignment purposes. The laser unit is connected to range detector and power supply modules by means of a shielded twisted pair cable.

A rugged, fully adjustable (azimuth/elevation) mount is also supplied with the system, along with a reflective target. The target is mounted on the wall or other crane that you wish to avoid hitting.

The range detector module contains three fully adjustable range detectors; a fault detector, and two out-of-sequence detectors. The range detectors are adjustable from 10 ft. to 150 ft. where the first point detector is set for the distance that you want the first stage of crane deceleration to take place. Range detector two sets stage two of deceleration, and the third detector is used to set the point where you want the crane brakes to be applied. The relationship between these points is as follows:

**150 ft. ≥ RANGE 1 > RANGE 2 > RANGE 3 ≥ 10 ft.**

If the above sequence is not maintained, an out-of-sequence error will occur which will dropout the third range point and the fault detector. This will stop the crane and prevent it from being moved in the protected direction until the sequence is corrected. One or both of the out-of-sequence LEDs will be on identifying which range detectors must be readjusted.

Adjusting the third range detector for less than 10 ft. will cause the third range detector and the fault detector to drop out. Setting the other range detectors for less than 10 ft. will cause an out-of-sequence error because the third range detector cannot be set for less than 10 ft. Each range detector and the fault detector have a form C relay output that is normally energized until a range point or a fault is detected. The markings on the range detector module show the de-energized state of the relays. Also contained in the range detector unit are the power supply and power input modules.

### **3-3. Optical Path Fault Detector**

This Laser Anti-Collision System contains a Laser Optical Fault Degradation Detector. When this system detects a loss in the optical path due to dirty optics, dirty target, obstructions between the two or misalignment of the laser and its target, it will produce a 30 second fault. This will cause the fault relay and the third range point relay to drop out for 30 seconds. After this 30-second period, the system will return back to normal operation until the fault is detected again. This is the only fault condition that lasts 30 seconds, (all other fault conditions do not time out) thereby making it easy to determine that an optical path problem has occurred and maintenance is needed to clean the lenses of the laser unit and/or the target. In some instances, the laser may have become loose and may need to be realigned. This unique circuitry performs a dynamic test every time the first range point is detected. It will produce the above described fault condition any time that this point is detected approximately 10% or more below its preset range.

### **3-4. Fault Relay**

A separate form C relay is provided to drive a warning light or enunciator in the event of a fault. The relay is normally energized and if a fault occurs the relay switches. Faults can be the loss of the target, setting out of sequence, laser head failure, or circuit failures.

## ***Section 3 – General System Information (Continued)***

### **3-5. System Specifications**

Operating range: 10 to 150 ft.

Laser Rating: Certified as Class 1 (eye safe)

Accuracy: Better than 0.5 ft. over the total range

Laser Beam: Modified for anti-collision applications

Control Outputs: Three relay contacts with 1 form C rated at 10 Amps, 270 VAC, 27 VDC

Fault Output: Relay output 1 form C rated at 10 Amps

Power Source: 95 to 130 VAC, 140 to 260 VAC, 180 to 300 VDC, and 8 to 30 VDC

Operating Temperature: -30°C to +70°C

Enclosure: NEMA 4 rating

Laser Unit Dimensions: Approximately 5.5" x 5.5" x 2.5"

Weight: 3.3 lbs.

Laser Support Unit Dimensions: Approximately 10" x 10" x 6"

Weight: 12.2 lbs.

Reflective Panel Dimensions: Approximately 24" x 24"

# **Section 4 – Installation Information**

## **CAUTION**

THE LASER CONTROL UNIT AND RELAYS ARE NOT RATED AS EXPLOSION PROOF. THE UNIT MUST NOT BE INSTALLED IN EXPLOSIVE ENVIRONMENTS UNLESS APPROPRIATE SECONDARY ENCLOSURE MEASURES ARE TAKEN.

### **4-1. Mounting Location Considerations.**

Ensure the mounting location is as far as possible from exposed trolley wires and sources of electromagnetic or radiated noise.

If possible, avoid installing receiver unit to a surface where high vibration or shock is present. If this cannot be avoided, use appropriate shock mounts.

### **4-2. Line Input Considerations.**

Check the system drawings for proper line input voltage. If there is any question as to proper line input voltage contact Telemotive before applying power to the unit.

## **WARNING**

THE UNIT MUST BE WIRED TO THE CORRECT VOLTAGE, FAILURE TO DO SO MAY DAMAGE THE SYSTEM.

## **NOTE**

THE UNIT SHOULD NOT BE CONNECTED TO LINES CONTAINING EXCESSIVE POWER UP TRANSIENTS OR CONTINUOUS COMMUTATOR NOISE. A LINE CONDITIONER MAY BE NECESSARY IN SOME INSTALLATIONS.

### **4-3. Wiring Considerations.**

1. Do not connect or disconnect wiring, or perform circuit checks while the power is turned on.
2. The motor wiring shall be in a separate metal conduit from the power wiring, which shall also be in metal conduit.
3. Low voltage wires shall be wired with Class 1 wiring.
4. Control wiring shall be in separate conduit and shall be kept as short as possible.

5. Control wiring for stepless devices shall be shielded twisted pair. The shield should be grounded at both ends.
6. All terminals shall be tightened to specified terminal torque (4.4 IN-LBS. unless otherwise specified).
7. Please observe National Electric Code (NEC) when wiring electrical devices.
8. When cutting holes in cabinet take care to prevent metal filings from shorting circuitry. Remove excess metal screws, metal filings and wire clippings from inside of unit.
9. Inspect to make sure no exposed wire has contact with any other wiring or terminals.
10. Suppressors are strongly recommended on all contactors.

### **4-4. Mechanical Installation**

The Anti-Collision System measures the distance between the laser unit's lens and the target surface. There must be no projections on the wall or the overhead crane that may extend in front of either (or both) the laser unit or the companion target.

Make sure the laser is mounted such that nothing can come between the laser's view of the target and at least 5 ft. (preferably 10 ft.) from walls or other objects that may act as a target. If your particular installation is a crane-to-crane application, do not mount the lasers on each crane so that their beam centers as they face each other are closer than 5 ft. (preferably 10 ft.) apart.

Determine the mounting position for the laser and the target such that the center of the laser's faceplate and the center of the target are the same distance above the plane the crane rails are in. The laser and target center point should also be the same distance from the rails. This is the most important part of a successful installation since the laser beam must stay on the target at all range points anywhere in the bay. Refer to Figures [6-8](#), [6-9](#) and [6-10](#) for mounting information.

Install the laser and the target in the positions found in steps above (refer to [Figure 6-1](#)). Mount the laser securely to a solid surface so that the crane's load or movement will not affect the laser's alignment. The laser should also be mounted as close

## Section 4 – Installation Information (Continued)

to the control panel as possible to minimize long cable runs. The range detector unit should be mounted next to the crane's control panel (refer to [Figure 6-12](#)).

Mounting of the reflector target is not as critical as the laser (refer to [Figure 6-11](#)).

For outdoor applications, care must be taken to assure all conduits and enclosures are sealed to prevent water from entering.

### 4-5. Electrical Installation

The laser unit interface cable and all other wiring should be run in separate 1/2" or 3/4" conduit. Do not run any other cables in the same conduit with the laser head cable.

A suitable disconnect should be provided by the installer.

Run conduit between the range detector unit and the crane's control panel.

Run conduit from the range detector unit to about 1 ft. from the laser unit. Putting a slight downward bend in the conduit at the laser transceiver will help keep dirt and water out. Place a protective end piece on the open end of the conduit to protect the laser cable from sharp edges.

Pull the supplied laser cable by the end that does not have a connector on it through the conduit starting from the opened laser unit end and into the range detector unit. Leave enough cable on the laser end so that it is twice as long as the distance between the end of the conduit and the laser unit (about 2 ft. to 3 ft.). This will produce a service loop, which will also help keep dirt and water out of the open end of conduit (refer to [Figure 6-2](#)). This cable consists of two twisted pairs of red and black wire and an un-insulated GND drain wire. See Figures [6-3](#), [6-4](#), [6-5](#), [6-6A](#) and [6-7](#) for wiring information for this cable. Plug the connector into the laser unit. The connector is keyed; do not force.

Two styles range detector boards are available; style A (E14001) with an external supply and style B (E14008) with integral regulator. Figures [6-3](#) (110/240 VAC), [6-5](#) (250 VDC), and [6-6A](#) (8-30 VDC) show the connections for style B. Figures [6-4](#) (110/240 VAC), [6-5](#) (250 VDC) and [6-6A](#) (8-30

VDC) show the connections for style A. Style B boards can directly replace style A boards.

Wire the outputs of the range detector unit (J1) to the crane control panel (refer to Figures [6-3](#), [6-4](#), [6-5](#), [6-6A](#) and [6-7](#)). Please note that the "NO" and "NC" markings on the range detector module are the conditions of the output relays when a range point or a fault has been detected. Place snubbers across the contactor coils in the crane's control panel that are to be controlled as necessary.

Run power to the power input module in the range detector unit (refer to Figures [6-3](#), [6-4](#), [6-5](#), [6-6A](#) and [6-7](#)). Make certain that the input power you provide matches the input requirements of the power supply used in this system. If it does not, stop here and notify Telemotive Customer Service.

Turn the power switch in the range detector unit on and note that the red LED on the laser head blinks on momentarily, and the green LED is blinking or on continuously. If the above does not occur, turn the power off and recheck all wiring.

For wiring special crane configurations such as magnetic control, timed bypass, stepped or stepless VFD, see the figures listed below in the back of the manual.

[Figure 6-14](#). Laser Guard Crane Magnetic Control, Protection in One Direction

[Figure 6-15](#). Laser Guard Crane Control with Timed Bypass, Protection in One Direction

[Figure 6-16](#). Laser Guard Stepped VFD or Magnetic Crane Control, Protection in Both Directions

[Figure 6-17](#). Laser Guard Stepped VFD or Magnetic Crane Control, Protection in One Direction

[Figure 6-18](#). Typical Laser Guard Interface with Stepless VFD Control

[Figure 6-19](#). Typical Laser Guard Interface with P&H Stepless VFD Control

### 4-6. Mechanical Alignment

Make initial adjustments of the range detectors as follows:

With a voltmeter connected between GND (TP4) and TP1, adjust the 1st range pot for 10V. (Refer to [Figure 6-13](#) for location of test points). Move the meter to TP2 and adjust the 2nd range pot for 5 V. Finally, move the meter to TP3 and adjust the 3rd range pot for 3 V. At this point, all out-of-sequence

## Section 4 – Installation Information (Continued)

LEDs (DS5 and DS6) should be off. If the out-of-sequence LEDs are on, recheck the above adjustments. Should these LEDs still be on, stop here and notify Telemotive Customer Service.

Move the crane with the laser to about 50 ft. to 75 ft. from its target. Turn all unnecessary power to the crane off, except for the laser system. Turn the power switch to the laser system on. If the power was on, turn it off and then back on again. Note that the red LED on the back of the laser head flashes on momentarily, and then the green LED on the back of the laser head will start blinking or be on continuously. If the red LED stays on, there is a fault condition with the laser unit and it will have to be replaced.

Loosen the two bolts on both sides of the "U" bracket of the laser mount and the one bolt at the bottom of the "U" bracket so the laser head can be moved up and down, and from left to right with just enough friction so the laser head does not fall over on its own.

By "eye sighting", try to point the laser head at the target. If the green LED on the back of the laser head should come on "steady", you are aimed "on target". Otherwise, you will find the target in the steps below:

While watching the green LED on the back of the laser head, move the laser head slowly up and down, and at the same time moving the laser even more slowly from side to side. Stop when the green LED starts blinking fast or comes on continuously.

Slowly move the laser head upward until the green LED starts to blink slowly. Note this point. Now move laser unit downward until the LED again blinks slowly. Note this point and position the laser unit halfway between these points. If you cannot find a point that makes the green LED blink fast or stay on continuously, then move the crane a little closer to the target and repeat the above steps. Alternately tighten the two bolts on the sides of the "U" bracket a little at a time until they are tight. This will prevent the laser unit from moving while tightening the bolts.

Now move the laser unit from side-to-side and note the points on both sides of the target that the green LED starts to blink slowly. Position the laser unit to the center of these two points. While keeping the laser unit from moving, carefully tighten the one bolt at the bottom of the "U" bracket.

### 4-7. Range Detector Settings (Static Method)

1. Park the crane in a safe place with all power removed from the crane controls. Apply power to the laser system. During the following adjustments, disregard the out-of-sequence lights.
2. Determine the range for the first point of crane deceleration (maximum range point). Determine the reference voltage for that range using the curve in [Figure 4-1](#), at the end of this Section.
3. With your voltmeter connected between GND (TP4) and TP1, (refer to [Figure 6-13](#) for test point location) adjust the first range point pot until the meter reads the same as the voltage in step (.2).
4. Determine the range for the second point of crane deceleration. This range point must be less than that in step (2). Determine the reference voltage for that range as in step (2).
5. With your voltmeter connected between the GND (TP4) and TP2, adjust the second range point pot until the meter reads the same as the voltage in step (4).
6. Determine the range for the third point where the brakes are to be applied. This range point must be less than that in step (4). Determine the reference voltage for that range as in step (2).
7. With your voltmeter connected between the GND (TP4) and TP3, adjust the third range point pot until the meter reads the same as the voltage in step (6). At this time, the out-of-sequence lights should not be lit. If they are, refer to the troubleshooting section in this manual.
8. Power up the crane and cautiously run the crane up and down the bay to verify that your settings are correct and the system functions properly for your application. You may "fine tune" these adjustments as necessary. Refer to the troubleshooting section ([Section 4-9](#) and [Table 4-2](#)) of this manual if out-of-sequence lights come on when fine-tuning.

### 4-8. Optical Path Fault Detector Checkout

This circuitry may be triggered while you are doing the installation and adjustment of the system, and it will not have any affect on the installation, since it is

## ***Section 4 – Installation Information (Continued)***

done in a static mode. Therefore, disregard the operation of these circuits during the installation. After the installation has been completed, you may have to wait 30 seconds before you can perform a dynamic test of the system.

The Laser Optical Path Fault Detector may be tested by bringing the laser to a distance from the target that is between the first and second range points, then momentarily block the laser's view of the target. This should cause a 30 second fault, which will light DS7 on the control board. If it does not, reduce the distance between the laser and the target and repeat the test. The required point to perform this test will vary with the application, depending on the range point settings used for the application.

### **CAUTION**

DO NOT WAIT FOR A FAULT TO OCCUR BEFORE PERFORMING PREVENTIVE MAINTENANCE. DO NOT CONTINUE TO RELY ON THE LASER GUARD SYSTEM IF A FAULT HAS OCCURRED UNTIL MAINTENANCE HAS CORRECTED THE PROBLEM.

#### **4-9. Troubleshooting (refer to [Table 4-2](#)).**

If the red LED on the laser head comes on continuously, replace the laser unit. Do not try to service it. Return it to the factory.

If the red LED on the laser head is blinking or the green LED on the back of the laser head is not on or blinking, check for +12V at terminals marked 12V and 12V COM at J2 on the range detector module. If 12V is not present, check the power supply and power input modules in the range detector unit. If 12V is present, turn the power off and check the continuity of the cable (refer to Figures [6-3](#), [6-4](#), [6-5](#), [6-6A](#) and [6-7](#)). Replace defective sub-assemblies as necessary. If none are found, replace the laser head.

When the laser head is greater than 150 ft. from its target, or a piece of black paper is placed over one of the laser's lenses (do not touch or scratch the lenses) the following conditions should exist on the range detector module:

The three red LEDs (DS1, DS2 and DS3) (refer to [Figure 6-13](#)) next to each range detector should be lit, and the red LED (DS4) by the fault detector should be lit. The two out-of-sequence red LEDs (DS5 and DS6) should be off. If one or both of the out-of-

sequence LEDs are on, check the three test point voltages and see that they meet the following relationship:

**150 ft.  $\geq$  RANGE 1 > RANGE 2 > RANGE 3  $\geq$  10 ft.**

If the above relationship is not correct, redo range detector module settings. ([Refer to Section 4-7](#))

If the out-of-sequence LEDs (DS5 and DS6) are not on, and any of the range detector or fault LEDs (DS1, DS2, DS3 and DS4) are off, check the voltage between signal in and COM at J2. Your meter should read between 0.3 VDC and 1.5 VDC. If the voltage is less than 0.3 VDC, either the laser cable is open or the laser unit has detected a fault condition within itself and must be replaced. If the voltage is within range, then check the third range detector test point and make sure it is above 2 VDC. If it is not, then redo the range detector module settings.

If 12 VDC is not present at the range detector module, check the fuse, power to the input of the power supply, power at the output of the power supply and power to the 12 VDC terminals of J2 on the range detector module. Correct any problems found.

If you cannot determine the source of your problem, please contact Telemotive.

If a laser head fault is detected with the style B (E14008) range detector board the unit will momentarily shut down the power to the head to attempt to reset the fault. If the fault is not reset after the first reset. The range detector board will not attempt another reset.



**Section 4 – Installation Information (Continued)**

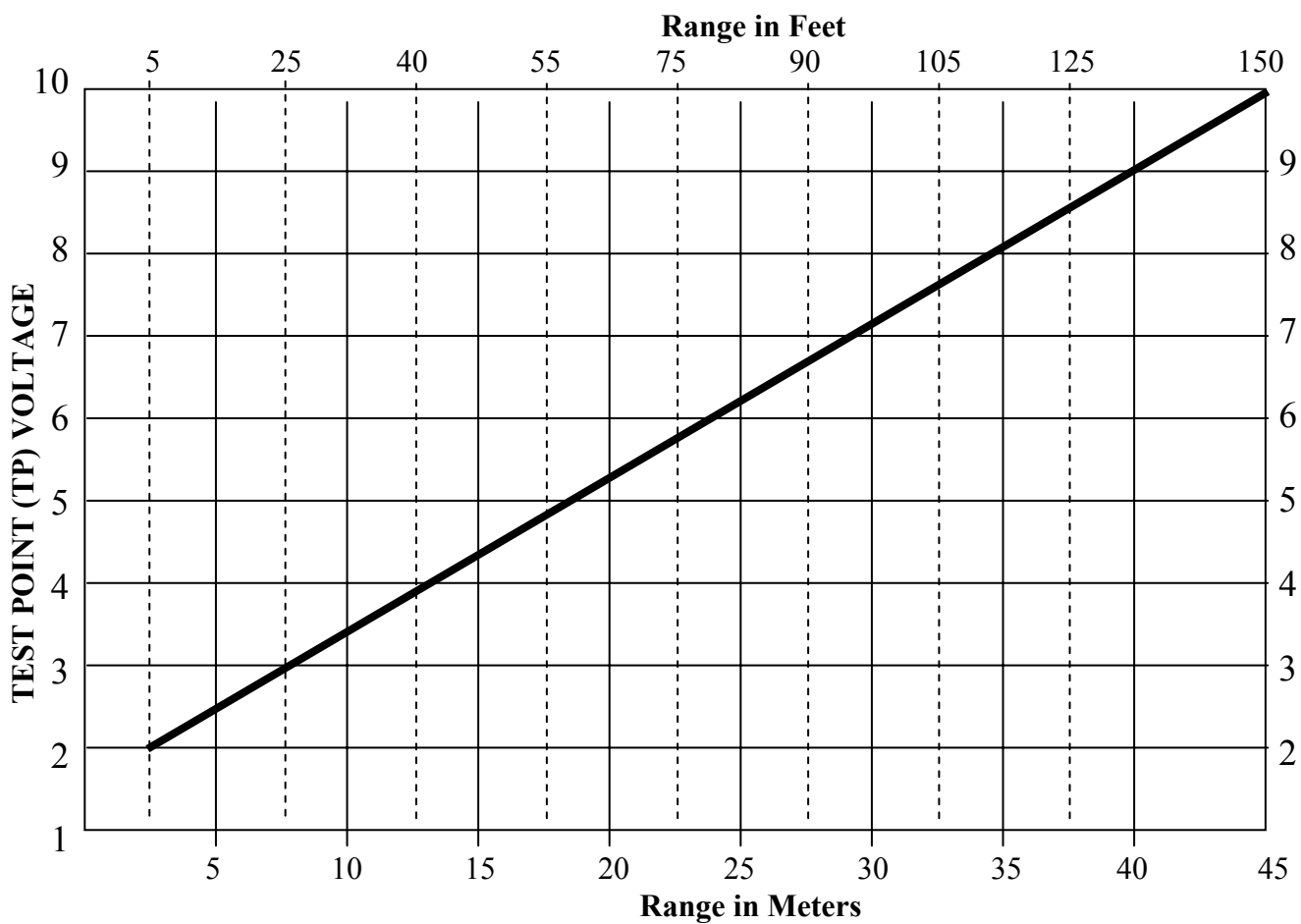

**Table 4-1. Range Verses Test Point Voltage**

## *Section 4 – Installation Information (Continued)*

**Table 4-2. Laser Diagnostic LED Functions (see Figure 6-13. for LED locations).**

<b>LED</b>	<b>COLOR</b>	<b>FUNCTION</b>
Laser Head Fault	Red	Monitors the internal circuitry to the Laser Head  Normally OFF.  If a Laser head malfunction is taken place the LED will light. Cycle power if the light remains on continuously replace head. If the LED is blinking check the 12 Volts to the head.
Laser Head Align	Green	Monitors target acquisition.  Normally ON when target is acquired. Flashes when head is working and target out of range.  If unit is not working and the green light is flashing check connections to head from control unit and target alignment.
Control Unit DS1, DS2 and DS3	Red	Monitors closure of the 1 <sup>st</sup> , 2 <sup>nd</sup> and 3 <sup>rd</sup> Range Point Relays K1, K2 and K3 respectively.  Normally ON when unit turned ON and out of range points.  The LEDs indicate power to the relay. The relays are normally energized. As the unit moves closer to the target the ranges point sequentially drop out thus turning of the LEDs in sequence.
Control Unit DS4	Red	Monitors engagement of the Fault Relay K4.  Normally ON when receiver turned ON.  The LED will extinguish when an OFF a fault of some type has been detected, thus tripping the relay. Check LEDS on laser head. DS5, DS6, DS7, DS8 and DS9 for possible fault conditions.
Control Unit DS5 and DS6	Red	Monitors the range set points between 1 <sup>st</sup> and 2 <sup>nd</sup> (2 <sup>nd</sup> Sequence LED) also 2 <sup>nd</sup> and 3 <sup>rd</sup> (3 <sup>rd</sup> Sequence LED) respectively.  Normally OFF.  If the trip points of the three ranges are not set in sequence one or both of these LEDs will light
Control Unit DS7	Red	Optical Path Fault Indicator.  Normally OFF.  The LED will go ON for dirty lens, misaligned target or Laser Head. Clean lens, target and check laser head alignment to target.
Control Unit E14008-0 Board only DS8	Green	Monitors regulated 12 VDC.  Normally ON.  DS2 off and DS1 on, check for shorts on regulated output or blown regulator. or a short on board.
Control Unit E14008-0 Board only DS9	Green	Monitors unregulated 12 VDC.  Normally ON.  Check fuse, wiring to unit and AC power to unit.

# **Section 5 – Laser Guard Replacement Parts**

## **5-1. PARTS LIST**

<b><u>Description</u></b>	<b><u>Part Number</u></b>
Laser Optical Unit	E14002-0
Laser Unit Mounting Kit	A14004-0
Interface Cable, 120 ft.	WA14001-120
NEMA 4 Enclosure	MP14005-0
Laser Range Detector Board (Style A)	E14001-1
Laser Range Detector Board (Style B)	E14008-0
Relay, 12 VDC, 10A, SPDT, Plug-In	K2110-0
Power Input Module (8-30 VDC Unit)	E10121-0
Power Input Module (10-40 VDC Unit)	A12160-5A
Power Input Module (110 VAC Unit) (Style A only)	A12160-202
Power Input Module (250 VDC Unit) 15W	A12160-0D5
Power Input Module (250 VDC Unit) 25W	A12160-0A8
Power Supply Module (110 VAC Unit) (Style A only)	E10186-1
Power Supply Module (250 VDC Unit) 15W	A5659-0
Power Supply Module (250 VDC Unit) 25W	A5661-0
Power Supply Module (10-40 VDC Unit) 15W	A5663-0
Power Supply Module (10-40 VDC Unit) 25W	A5656-0
Reflector Target	A14006-0
Bracket, Mounting Kit (for E14003-X)	MP1306-0
User / Installation Manual	TC14K-0

# Section 6 – Installation Diagrams

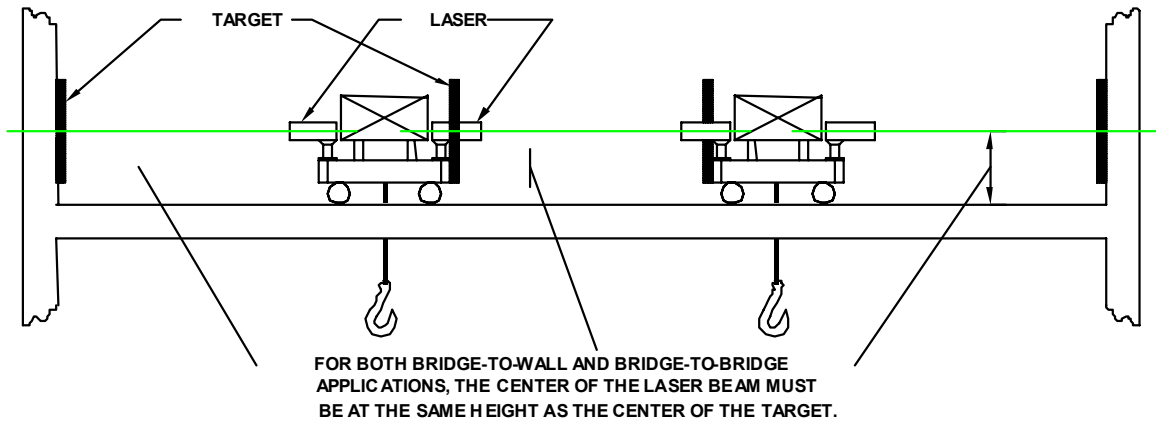
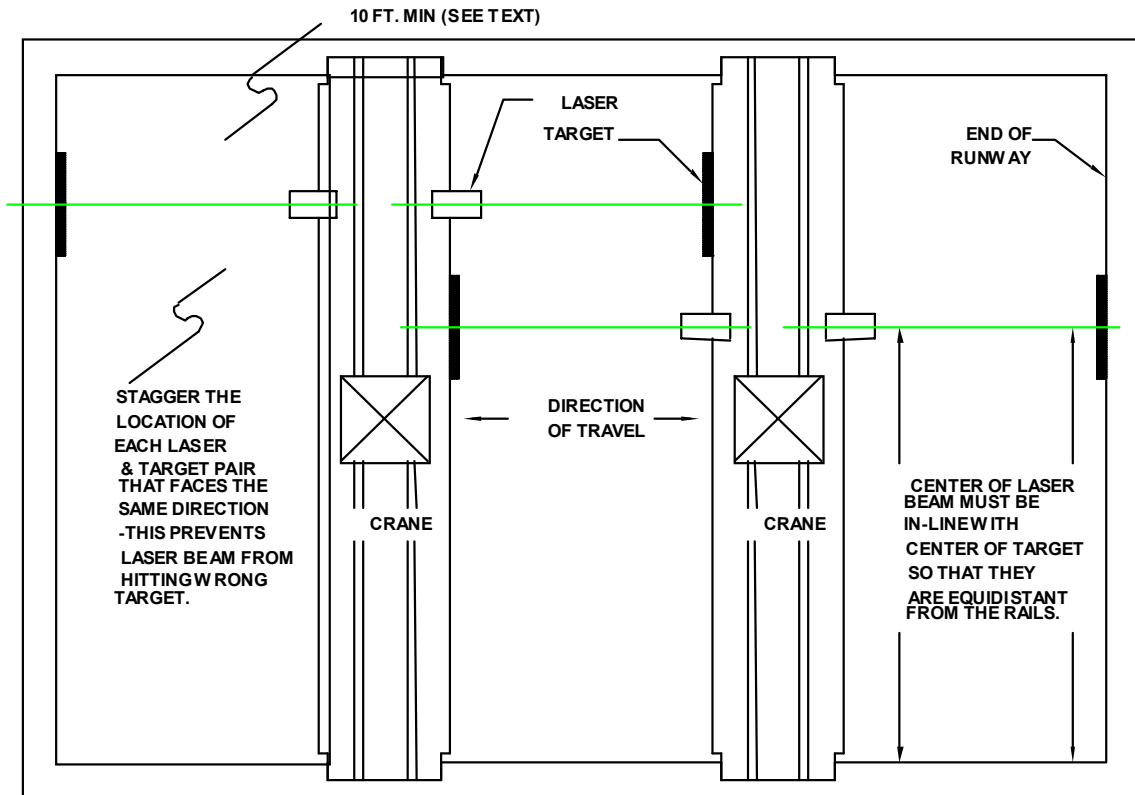
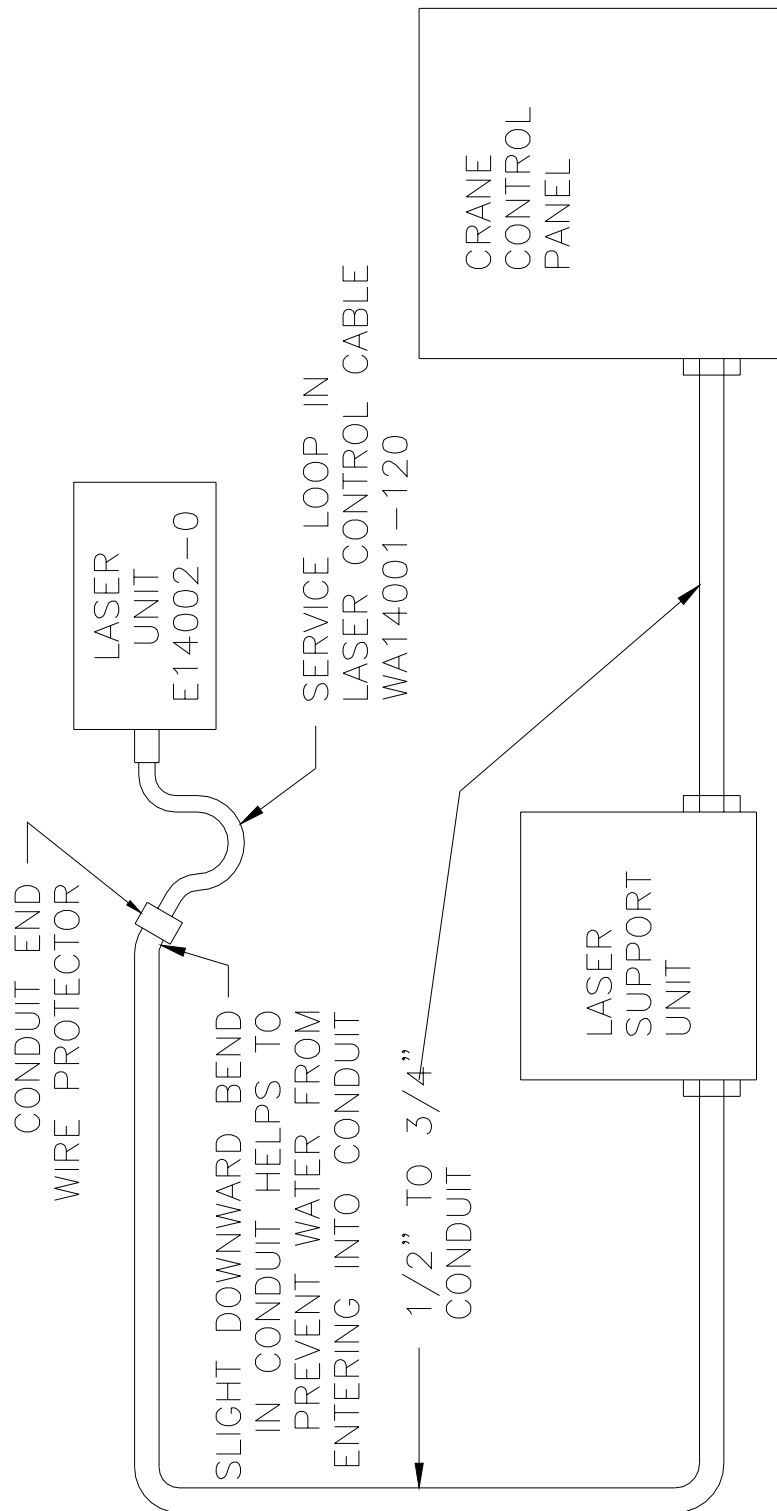

Figure 6-1. Laser and Target Installation

**Section 6 – Installation Diagrams (Continued)**



**Figure 6-2. Conduit Installation**

## Section 6 – Installation Diagrams (Continued)

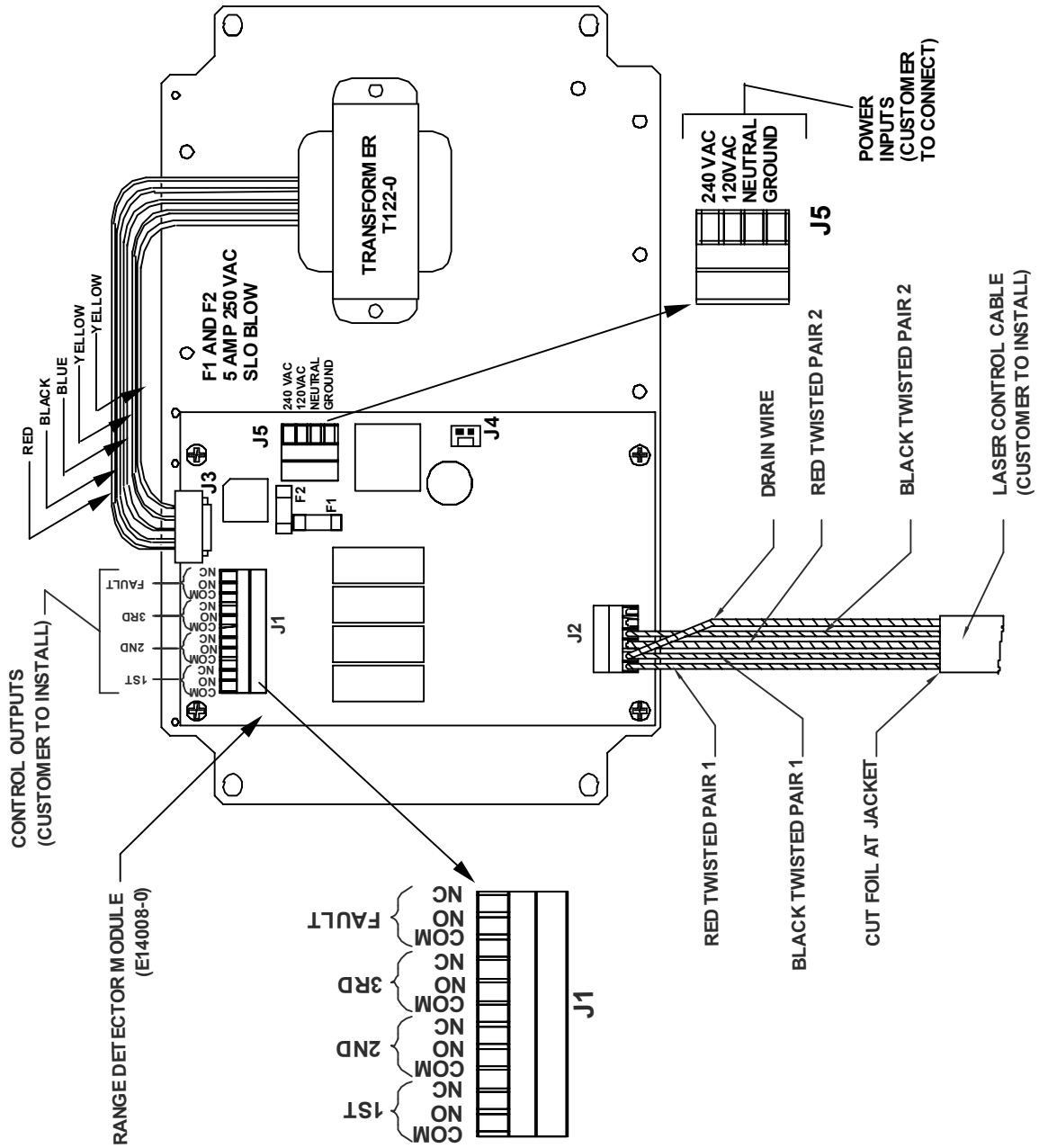
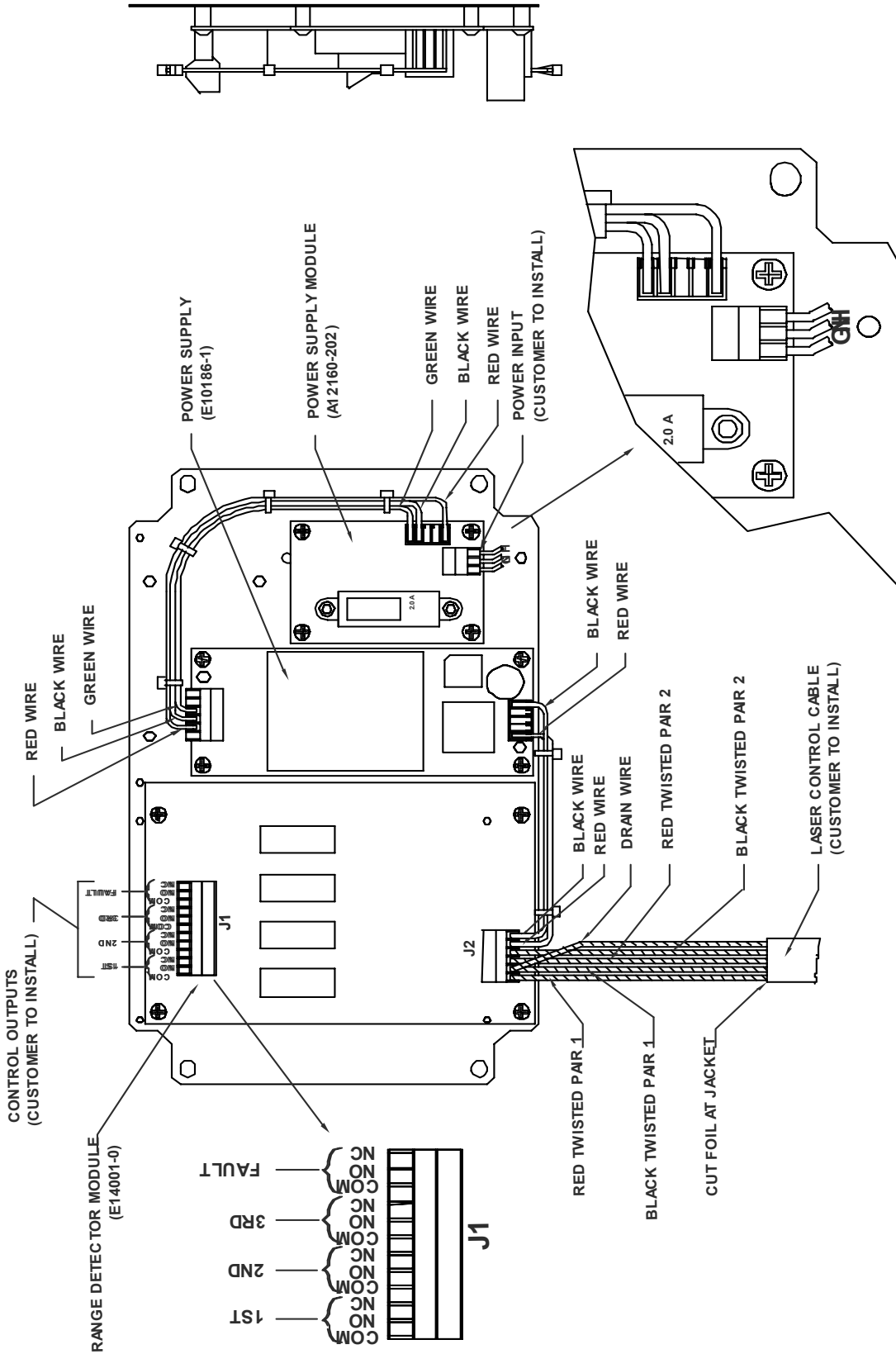
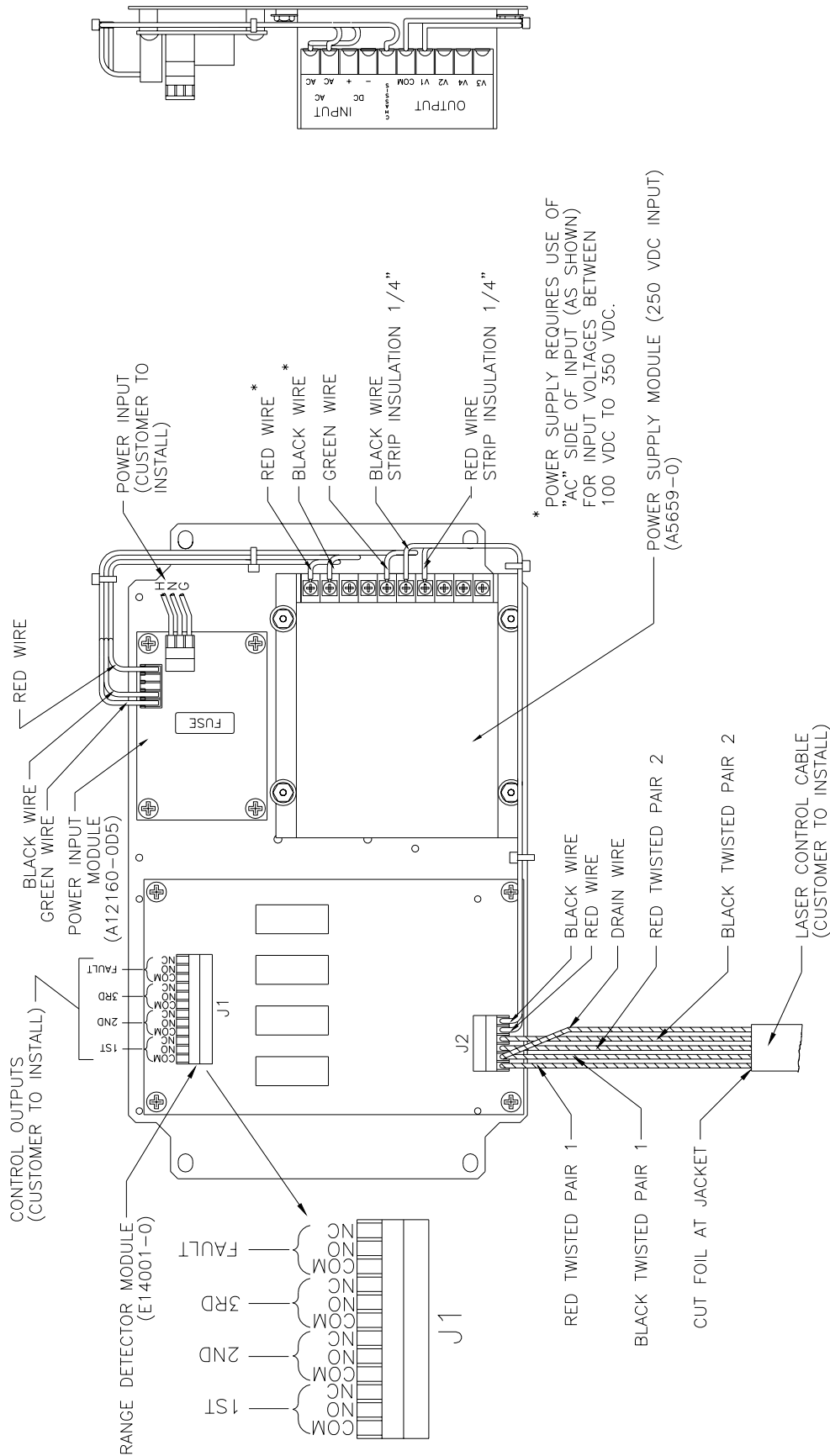

Figure 6-3. Laser Support Unit E14008-0 Board Wiring (110 VAC and 240 VAC Unit)

## Section 6 – Installation Diagrams (Continued)



## Section 6 – Installation Diagrams (Continued)



**Figure 6-5. Laser Support Unit E14008-0 and E14001-0 Board Wiring (250 VDC Unit)**



## Section 6 – Installation Diagrams (Continued)

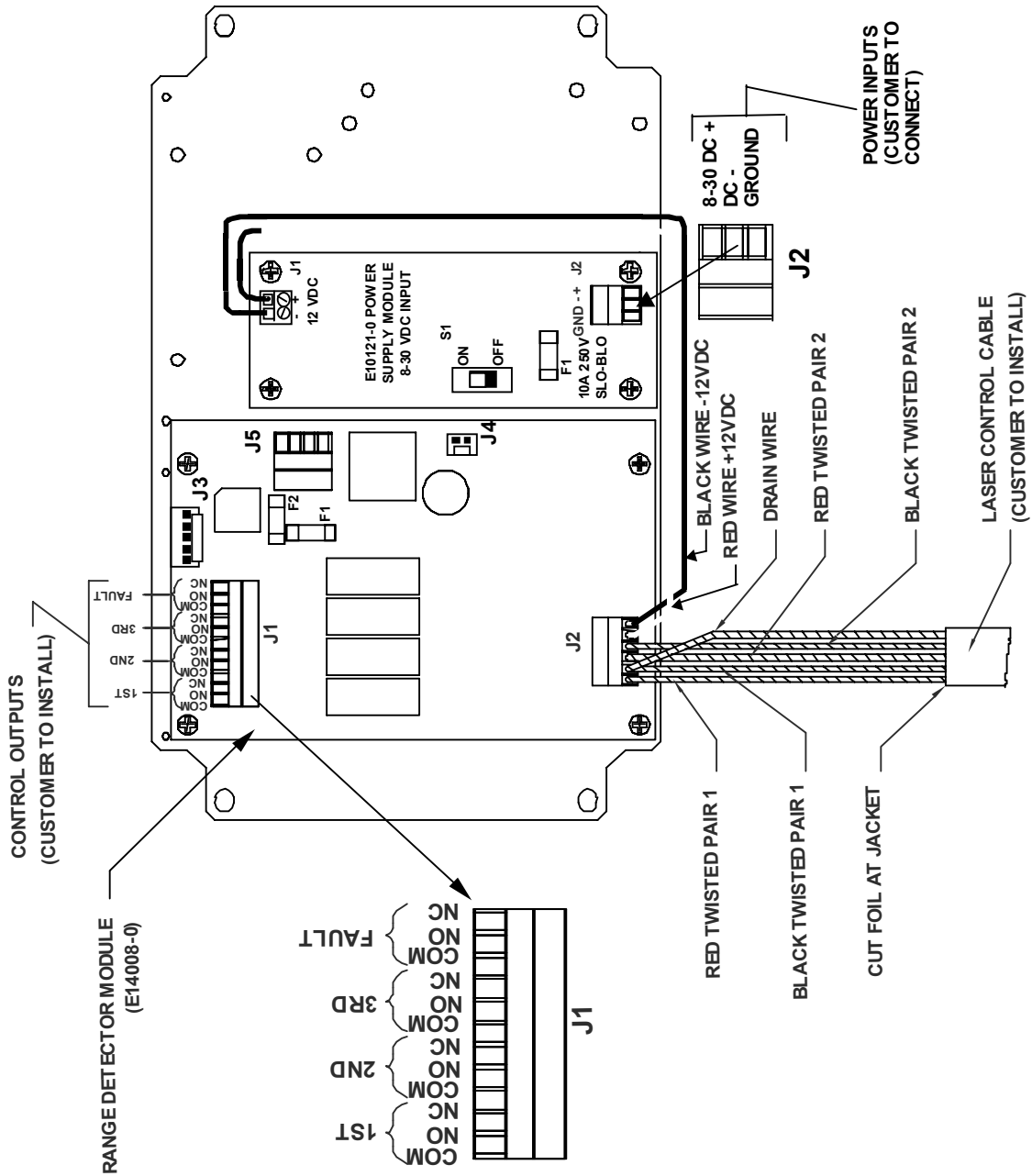

**Figure 6-6A. Laser Support Unit E14008-0 and E14001-0 Board Wiring (8-30 VDC Unit)**

## Section 6 – Installation Diagrams (Continued)

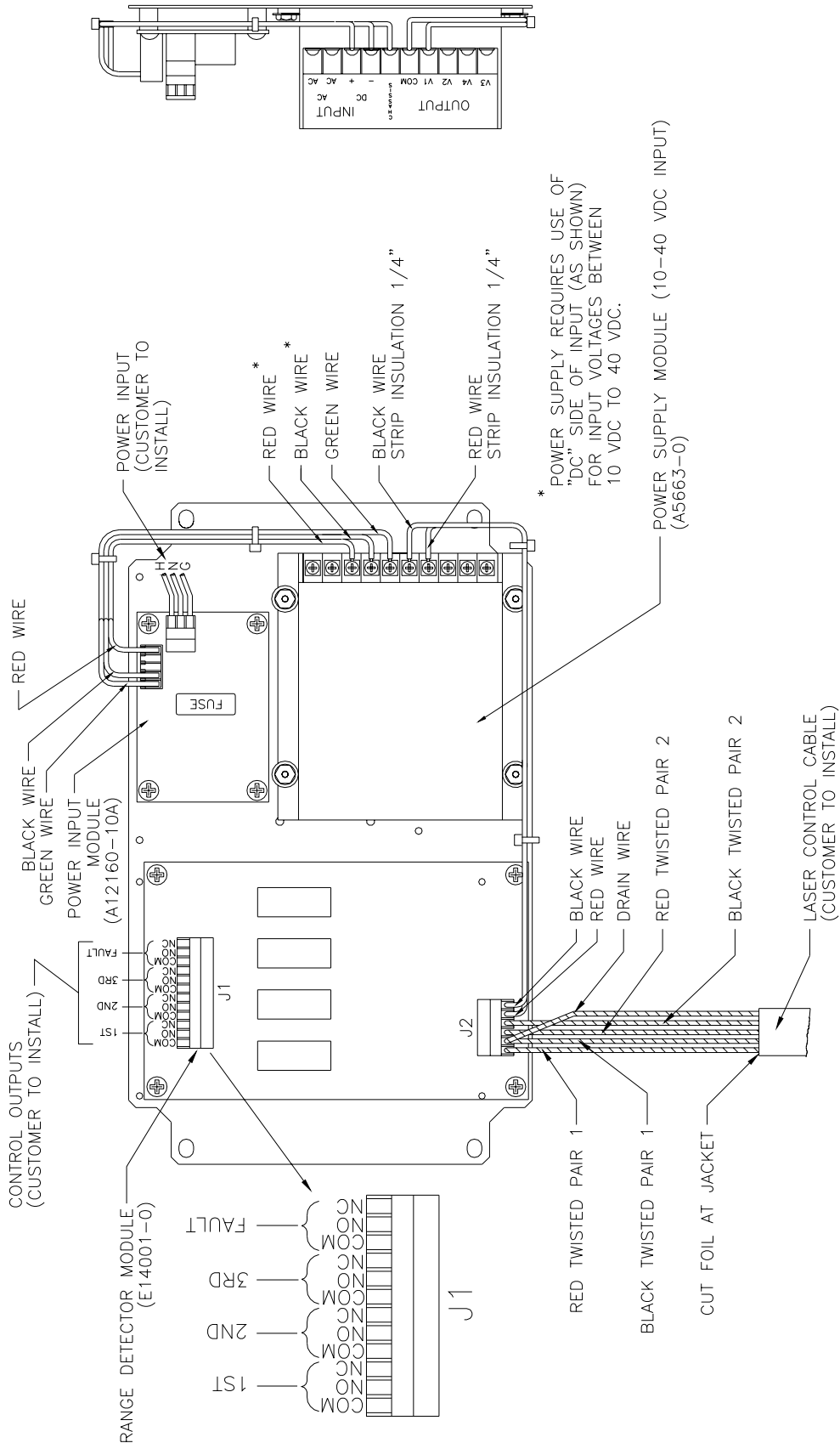

**Figure 6-6B. Laser Support Unit E14008-0 and E14001-0 Board Alternate Wiring (10-40 VDC Unit)**

## Section 6 – Installation Diagrams (Continued)

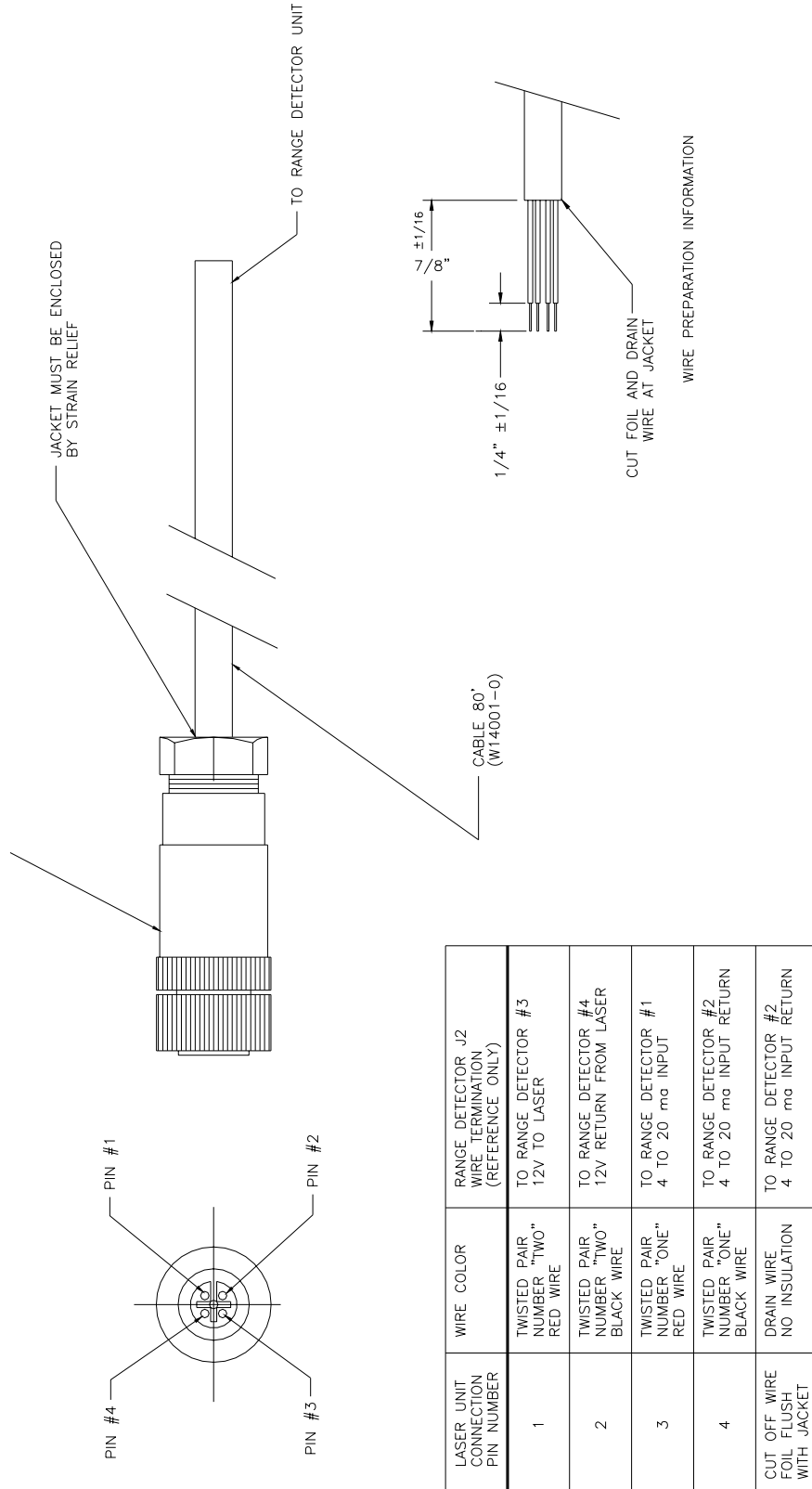
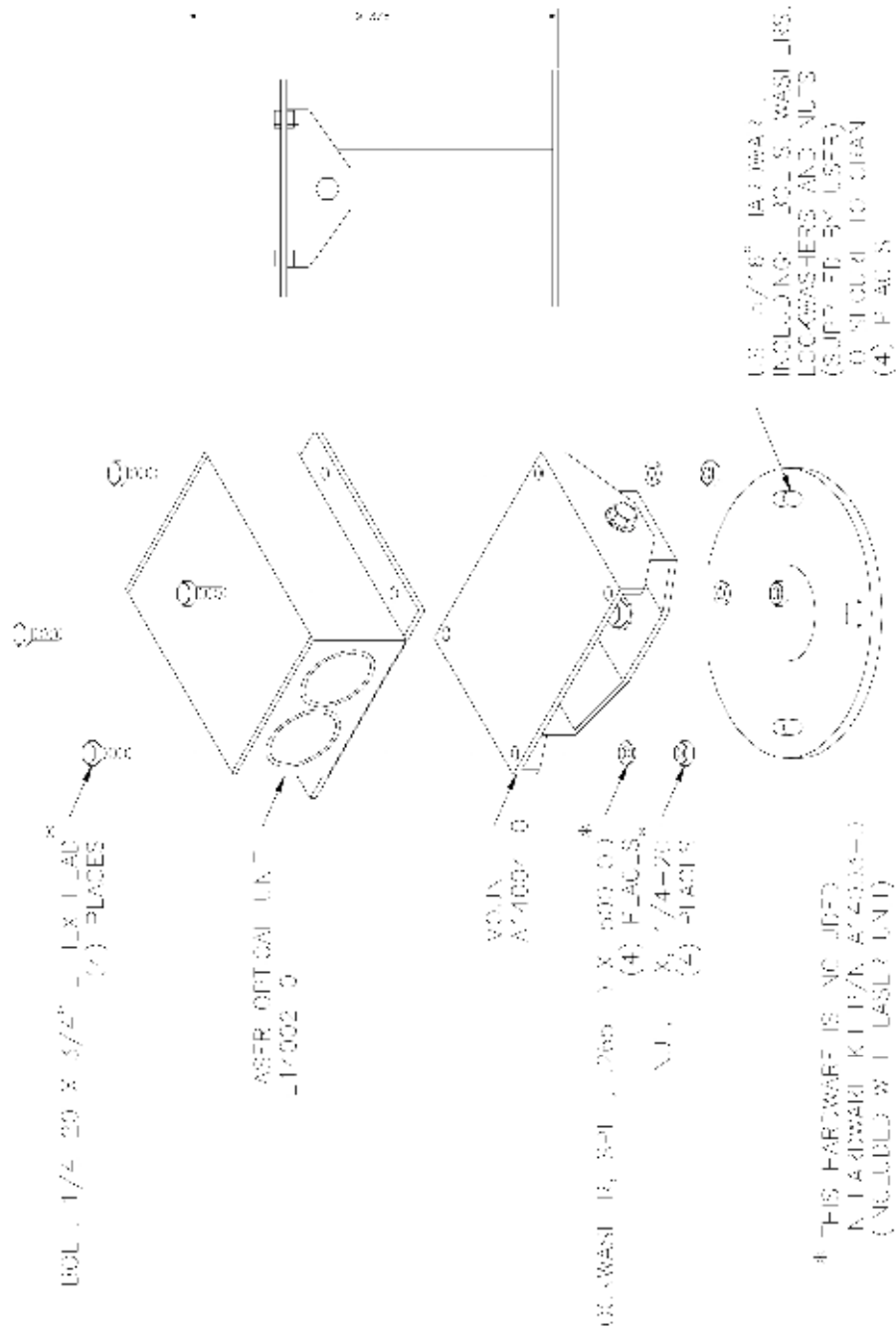

FIGURE 5: LASER CONNECTOR WIRING DIAGRAM

**Figure 6-7. Laser Connector Wiring Diagram**

**Section 6 – Installation Diagrams (Continued)**



**Figure 6-8. Laser Optical Unit and Mounting Assembly**

**Section 6 – Installation Diagrams (Continued)**

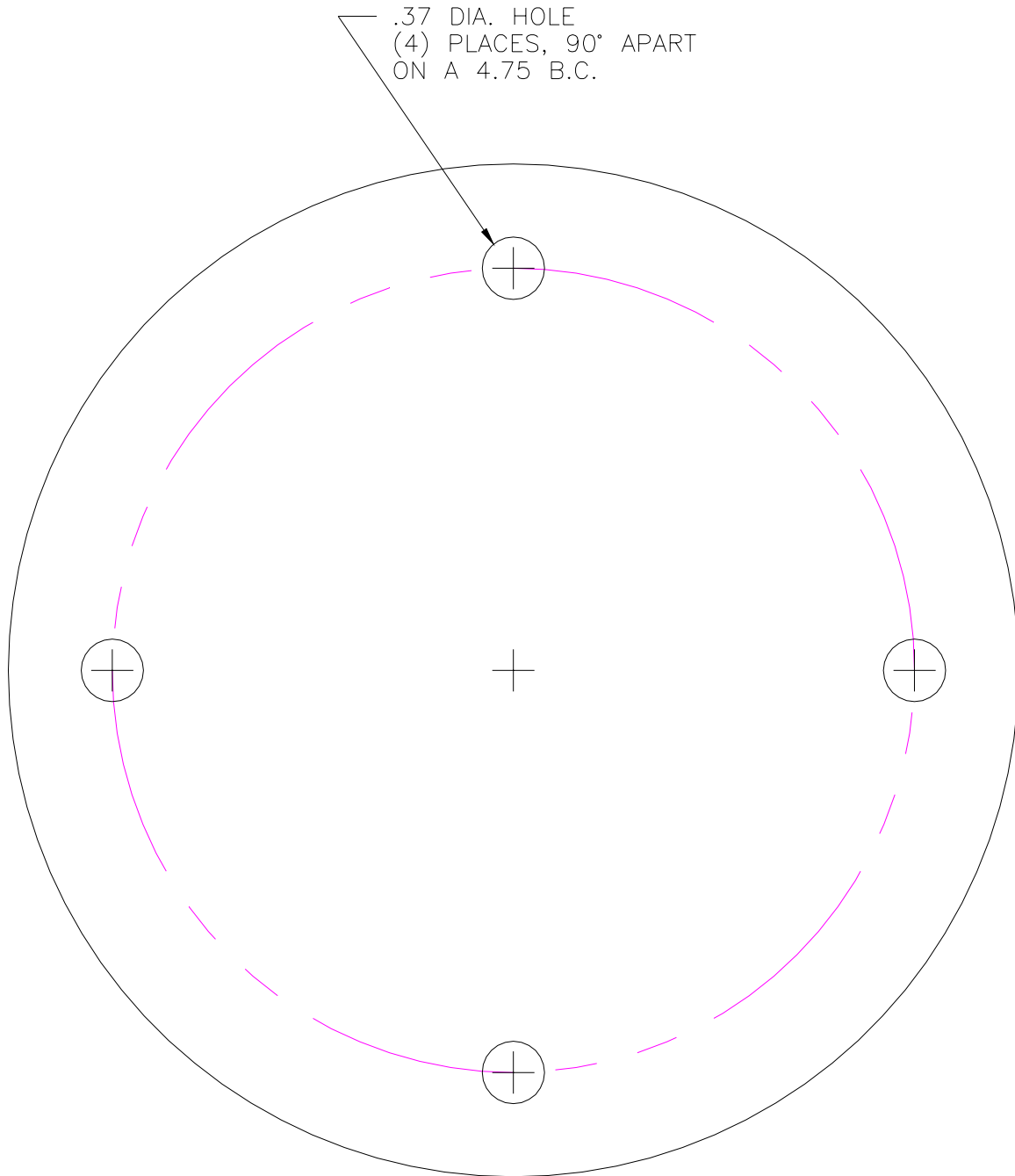

Not to scale all dimensions in inches

**Figure 6-9. Template for Laser Base Mounting Holes**



*Section 6 – Installation Diagrams (Continued)*

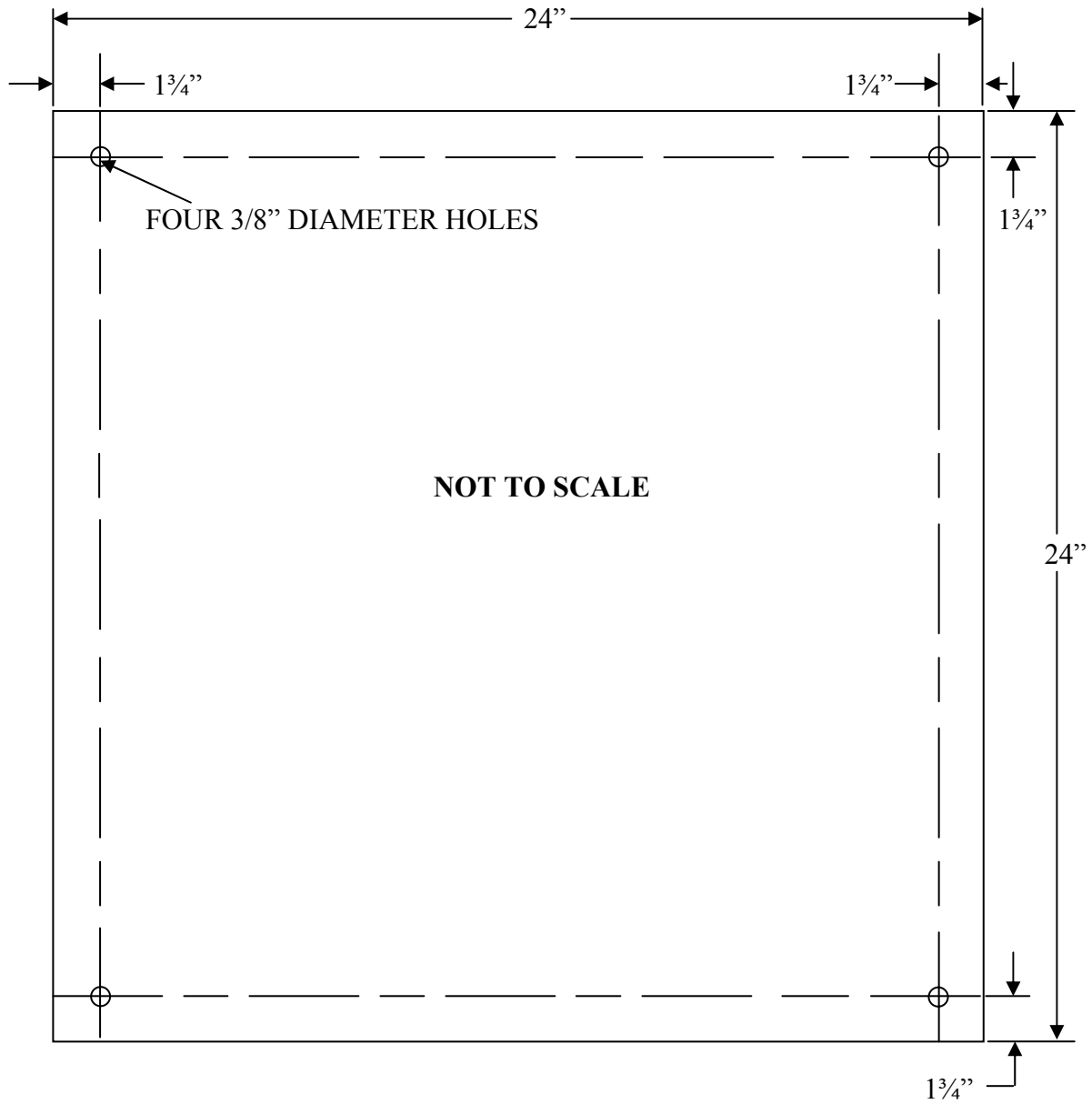

**Figure 6-11. Target Dimensions**

**Section 6 – Installation Diagrams (Continued)**

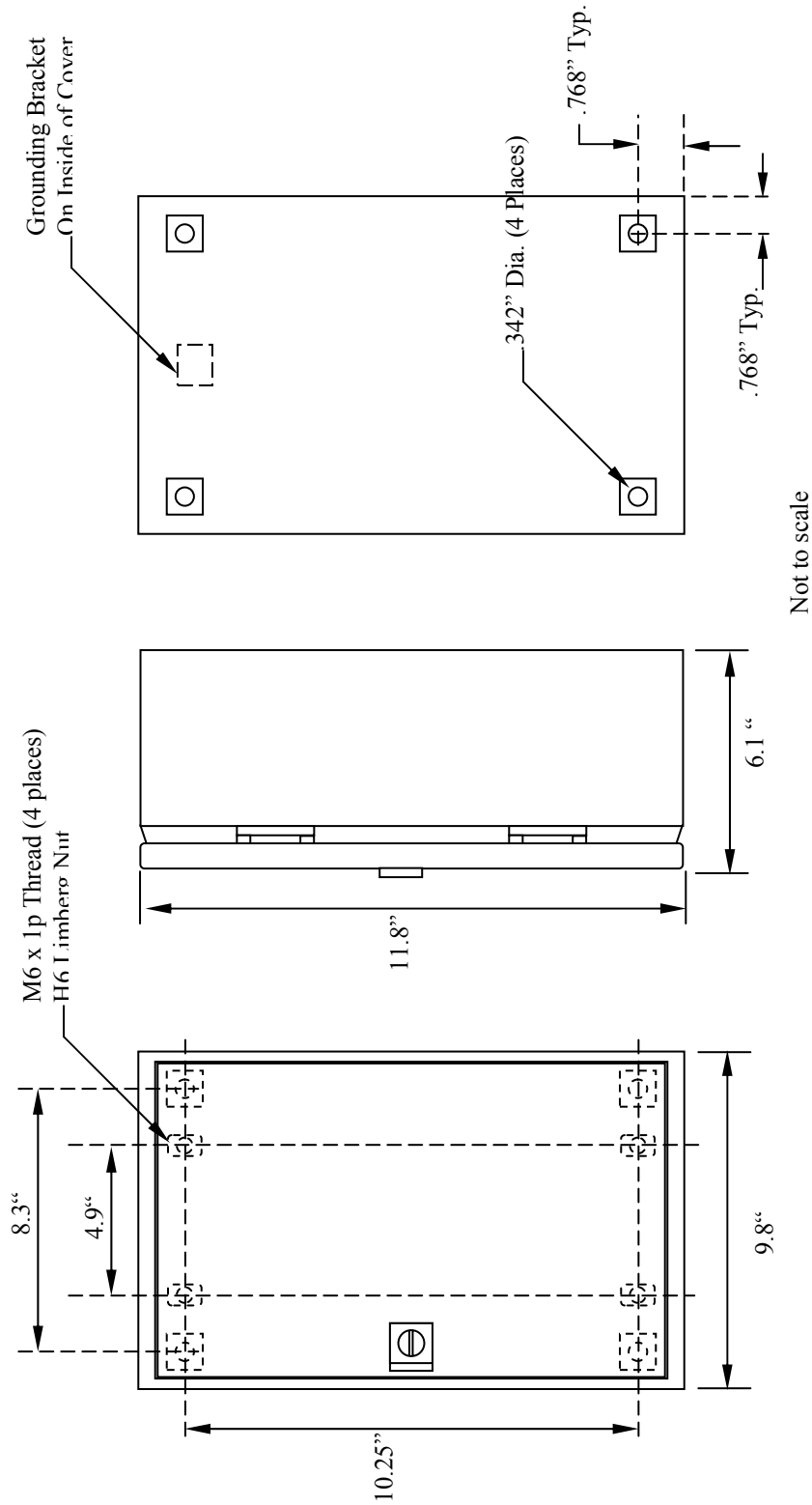

**Figure 6-12. Enclosure Dimensions**



**Section 6 – Installation Diagrams (Continued)**

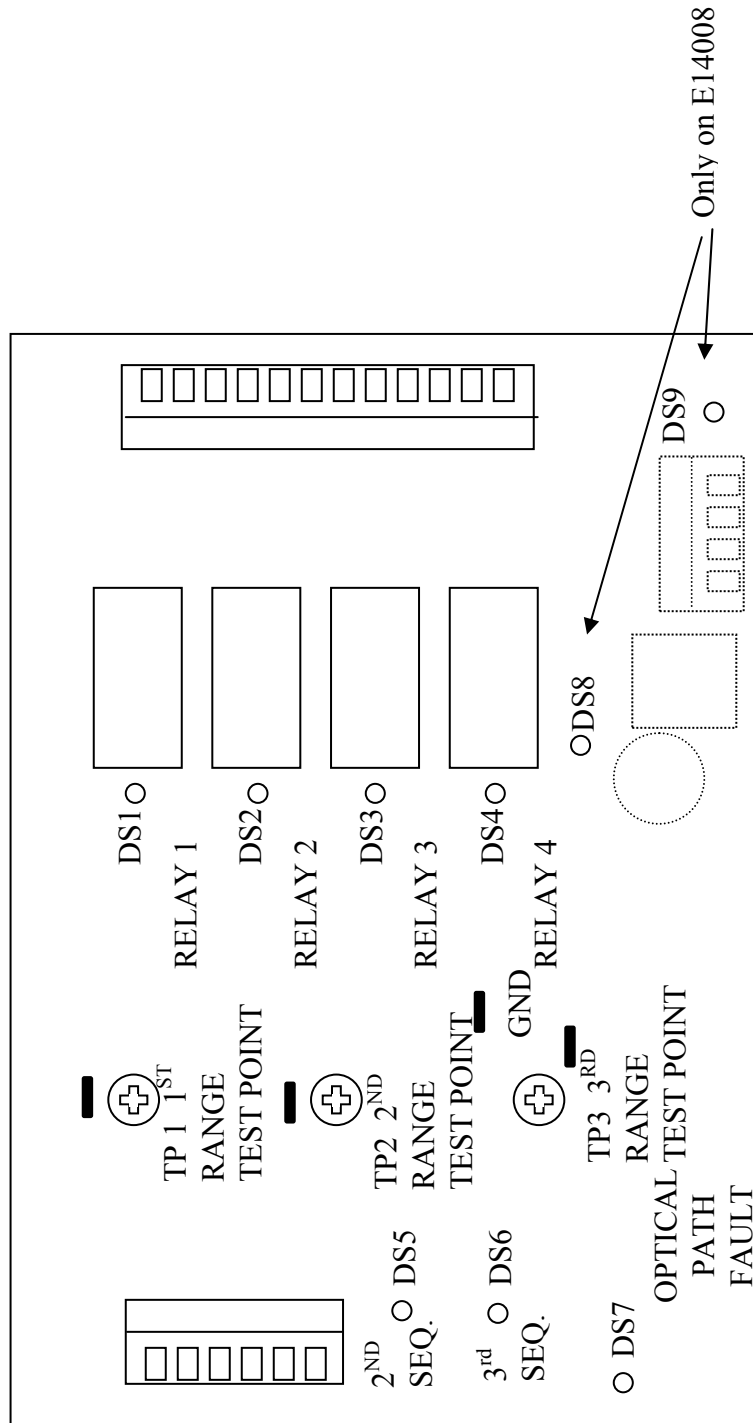

**Figure 6-13. Test Point Locations**

# Section 6 – Installation Diagrams (Continued)

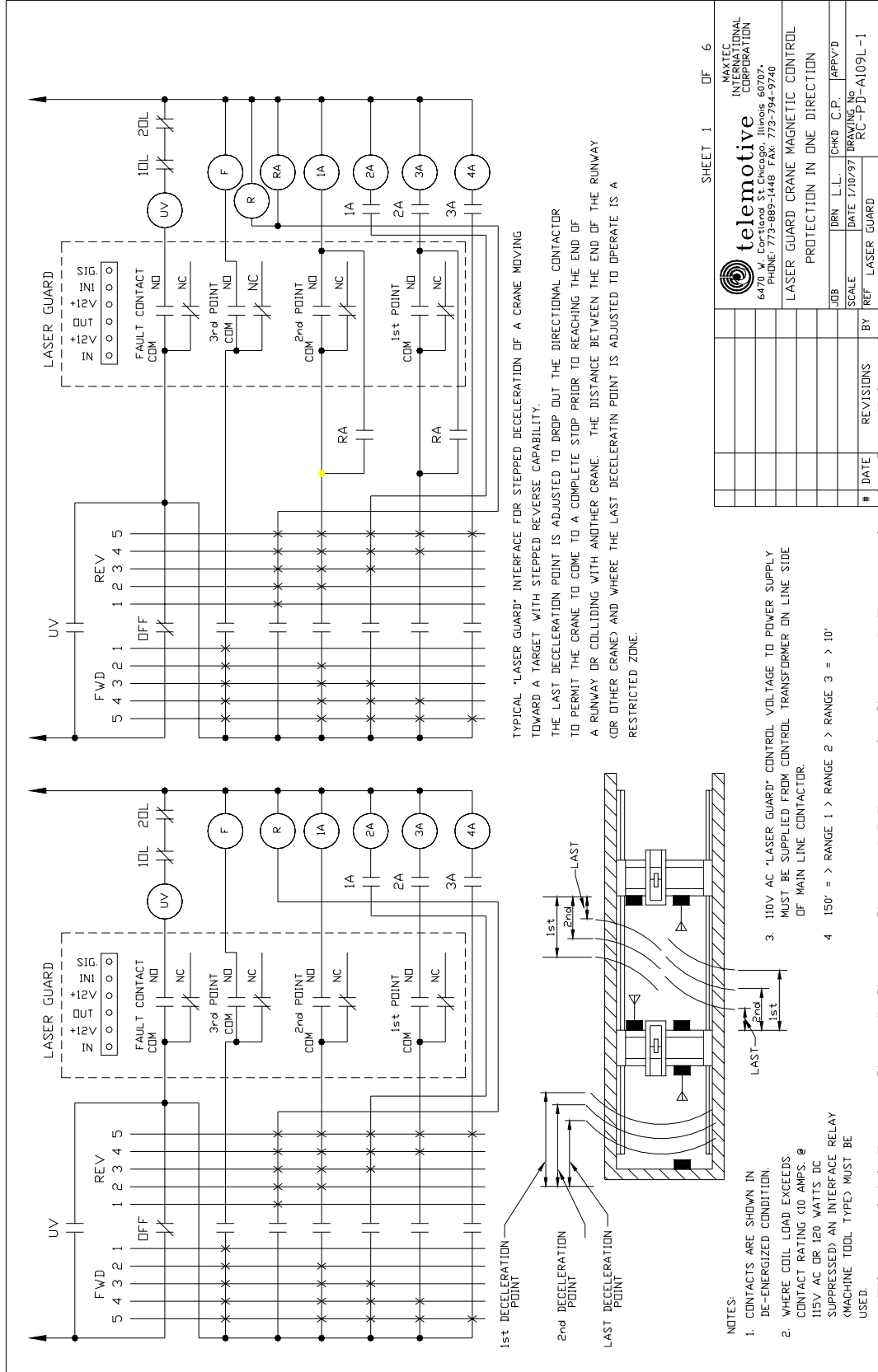

SHEET 1 OF 6

<b>telemotive</b> MAXTEC INTERNATIONAL CORPORATION 6470 W. Cortland, St. Charles, Illinois 60707 PHONE: 773-889-1448 FAX: 773-794-9740	
LASER GUARD CRANE MAGNETIC CONTROL PROTECTION IN ONE DIRECTION	
JOB #	CHKD. C.P. APPV'D
SCALE	DATE 1/10/97 DRAWING NO.
#	DATE REVISIONS BY REF. LASER GUARD RC-PD-A109L-1



# Section 6 – Installation Diagrams (Continued)

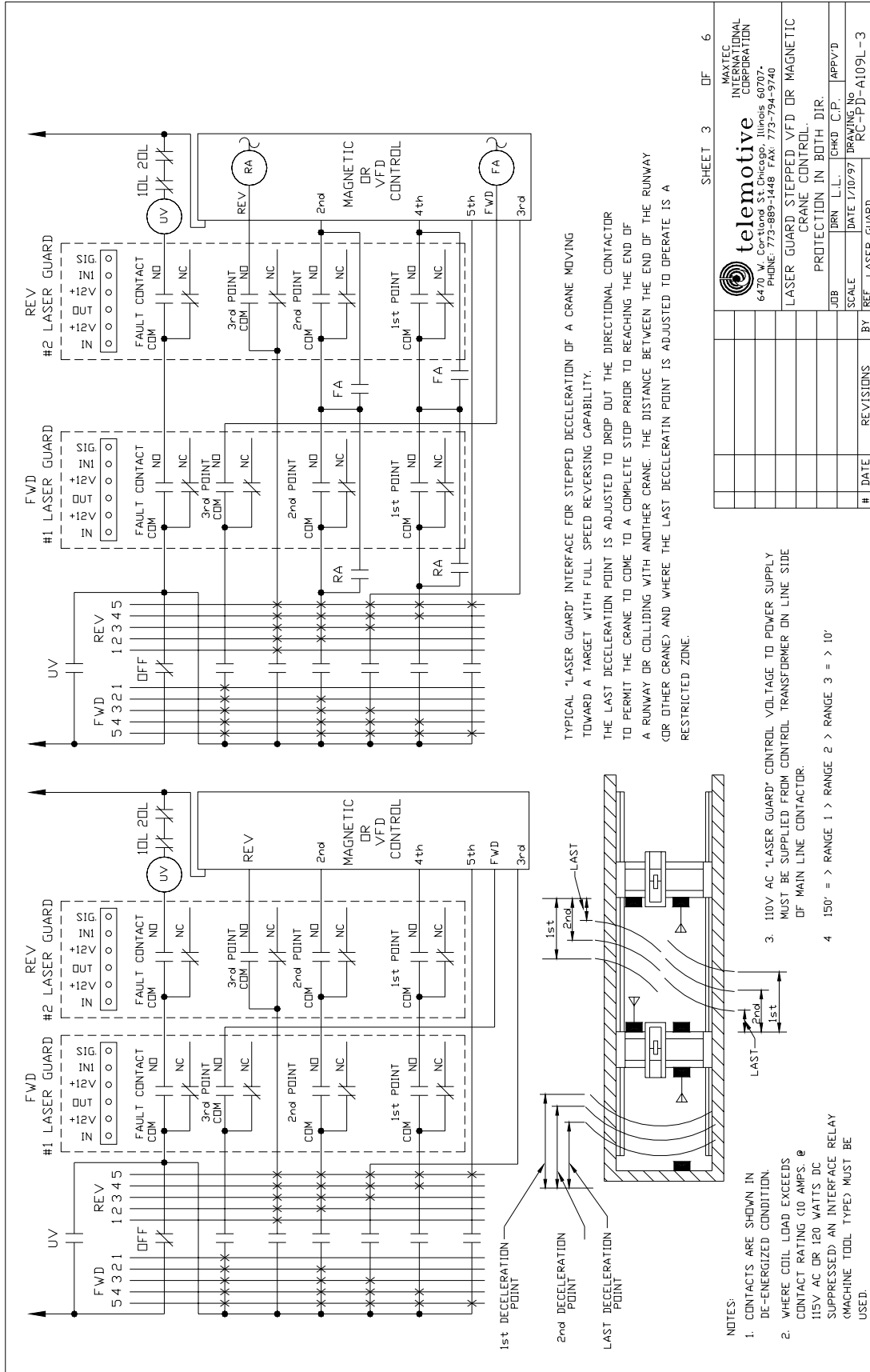

**Figure 6-16. Laser Guard Stepped VFD or Magnetic Crane Control, Protection in Both Directions**







## ***Section 6 – Installation Diagrams (Continued)***

This page intentionally left blank