

FJL680-4

Operating, Maintenance & Parts Manual

FEL Series

Models

1/4 Ton
FEL0516
FEL0532

1/2 Ton
FEL1016
FEL1032

1 Ton
FEL2016

2 Ton
FEL4008



Follow all instructions and warnings for inspecting, maintaining and operating this hoist.

The use of any hoist presents some risk of personal injury or property damage. That risk is greatly increased if proper instructions and warnings are not followed. Before using this hoist, each operator should become thoroughly familiar with all warnings, instructions, and recommendations in this manual. Retain this manual for future reference and use.

Forward this manual to the hoist operator.

Failure to operate the equipment as directed in the manual may cause injury.

Should you have any questions regarding this product, please call Little Mule at **(800) 477-5003**.

Before using the hoist, fill in the information below. Model and serial numbers are stamped into the aluminum hoist housing.

Model Number _____

Serial Number _____

Purchase Date _____



Electric chain

SAFETY PRECAUTIONS

Each Little Mule FEL Series Electric Chain Hoist is built in accordance with the specifications contained herein and at the time of manufacture complies with our interpretation of applicable sections of *American Society of Mechanical Engineers Code (ASME) B30.16 "Overhead Hoists," the National Electrical Code (ANSI/NFPA 70) and the Occupational Safety and Health Act (OSHA). Since OSHA states the National Electrical Code applies to all electric hoists, installers are required to provide current overload protection and grounding on the branch circuit section in keeping with the code. Check each installation for compliance with the application, operation and maintenance sections of these articles.

*Copies of this standard can be obtained from ASME Order Department, 22 Law Drive, Box 2300, Fairfield, NJ 07007-2300, U.S.A.

WARNING

Improper operation of a hoist can create a potentially hazardous situation which, if not avoided, could result in death or serious injury. To avoid such a potentially hazardous situation, THE OPERATOR SHALL:

1. **NOT** operate a damaged, malfunctioning or unusually performing hoist.
2. **NOT** operate the hoist until you have thoroughly read and understood this Operating, Maintenance and Parts Manual.
3. **NOT** operate a hoist which has been modified without the manufacturer's approval or without certification that it is in conformity with ASME B30.16.
4. **NOT** lift more than rated load for the hoist.
5. **NOT** use hoist with twisted, kinked, damaged, or worn load chain.
6. **NOT** use the hoist to lift, support, or transport people.
7. **NOT** lift loads over people.
8. **NOT** operate a hoist unless all persons are and remain clear of the supported load.
9. **NOT** operate unless load is centered under hoist.
10. **NOT** attempt to lengthen the load chain or repair damaged load chain.
11. Protect the hoist's load chain from weld splatter or other damaging contaminants.
12. **NOT** operate hoist when it is restricted from forming a straight line from hook to hook in the direction of loading.
13. **NOT** use load chain as a sling, or wrap chain around load.
14. **NOT** apply the load to the tip of the hook or to the hook latch.
15. **NOT** apply load unless load chain is properly seated in the chain sprocket(s).
16. **NOT** apply load if bearing prevents equal loading on all load supporting chains.
17. **NOT** operate beyond the limits of the load chain travel.
18. **NOT** leave load supported by the hoist unattended unless specific precautions have been taken.
19. **NOT** allow the load chain or hook to be used as an electrical or welding ground.

20. **NOT** allow the load chain or hook to be touched by a live welding electrode.
21. **NOT** remove or obscure the warnings on the hoist.
22. **NOT** operate a hoist on which the safety placards or decals are missing or illegible.
23. **NOT** operate a hoist unless it has been securely attached to a suitable support.
24. **NOT** operate a hoist unless load slings or other approved single attachments are properly sized and seated in the hook saddle.
25. Take up slack carefully - make sure load is balanced and load holding action is secure before continuing.
26. Shut down a hoist that malfunctions or performs unusually and report such malfunction.
27. Make sure hoist limit switches function properly.
28. Warn personnel of an approaching load.

CAUTION

Improper operation of a hoist can create a potentially hazardous situation which, if not avoided, could result in minor or moderate injury. To avoid such a potentially hazardous situation, THE OPERATOR SHALL:

1. Maintain firm footing or be otherwise secured when operating the hoist.
2. Check brake function by tensioning the hoist prior to each lift operation.
3. Use hook latches. Latches are to retain slings, chains, etc. under slack conditions only.
4. Make sure the hook latches are closed and not supporting any parts of the load.
5. Make sure the load is free to move and will clear all obstructions.
6. Avoid swinging the load or hook.
7. Make sure hook travel is in the same direction as shown on the controls.
8. Inspect the hoist regularly, replace damaged or worn parts, and keep appropriate records of maintenance.
9. Use Little Mule recommended parts when repairing the unit.
10. Lubricate load chain per hoist manufacturer's recommendations.
11. **NOT** use the hoist's overload limiting clutch to measure load.
12. **NOT** use limit switches as routine operating stops. They are emergency devices only.
13. **NOT** allow your attention to be diverted from operating the hoist.
14. **NOT** allow the hoist to be subjected to sharp contact with other hoists, structures, or objects through misuse.
15. **NOT** adjust or repair the hoist unless qualified to perform such adjustments or repairs.

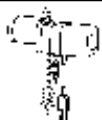

TABLE OF CONTENTS

Safety Precautions.....	2
Hoist Specifications.....	3
Application Information	4
Safety Information	4
Installation	4
Operation	6
Maintenance	6
Wiring Diagrams	12
Trouble Shooting	13
Inspection and Maintenance Check List	14
Recommended Lubrication Schedule.....	15
Replacement Parts List.....	17
Parts Depot & Warranty Repair Centers.....	30
Warranty	Back Cover

HOIST SPECIFICATIONS

Little Mule electric chain hoists are rugged, portable hoists that provide quick, precise lifting. The hoists are constructed of tough, but lightweight, die cast aluminum alloy housings. An oil bath transmission, equipped with heat-treated, alloy steel gears and an overload limiting clutch, provides smooth and reliable operation.

With a pushbutton station that fits comfortably in one hand, the operator can safely control the hoist while the other hand is free to guide the load. The electrical controls, which are readily accessed under the electrical cover, utilize quick connections for easy voltage conversions and a 24V control circuit for added safety.

Table 1 - Hoist Specifications

Model	Capacity (tons)	Lifting Speed (fpm)	Reeving	HP	Voltage	Full Load Motor Amps*
FEL0516-1	1/4	16	Single-chained	1/4	115/230V	4.3/2.15
FEL0516-3	1/4	16	Single-chained	1/4	230/460V	.9/.45
FEL0532-1	1/4	32	Single-chained	1/2	115/230V	7.6/3.8
FEL0532-3	1/4	32	Single-chained	1/2	230/460V	2/1
FEL1016-1	1/2	16	Single-chained	1/2	115/230V	7.6/3.8
FEL1016-3	1/2	16	Single-chained	1/2	230/460V	2/1
FEL1032-1	1/2	32	Single-chained	1	115/230V	14/7**
FEL1032-3	1/2	32	Single-chained	1	230/460V	3.2/1.6
FEL2016-1	1	16	Single-chained	1	115/230V	14/7**
FEL2016-3	1	16	Single-chained	1	230/460V	3.2/1.6
FEL4008-1	2	8	Double-chained	1	115/230V	14/7**
FEL4008-3	2	8	Double-chained	1	230/460V	3.2/1.6

* At full load, it is not unusual for the hoist to draw in excess of the values listed when lifting. It is critical to ensure that the voltage at the hoist contactor does not drop below 10% of the nominal voltage of the hoist while it is lifting a load. Low voltage will result in higher amp draw, damage to the hoist, and potential fire hazards. Little Mule is not responsible for any damages caused by an inadequate power source.

Other features that ensure the safe operation of Little Mule electric chain hoists include a magnetic disc brake that delivers sure stopping and secure holding of the load. Adjustable upper and lower limit switches regulate the load travel. As a standard, hooks are supplied with safety latches. For additional safety, a chain stop is attached to the slack end of the load chain.

Little Mule electric chain hoists are designed and tested in accordance with the American Society of Mechanical Engineers Code B30.16, "Safety Standard for Overhead Hoists." Hoists are built in compliance with CSA, file number LR 44484. Made in U.S.A.

**The 1HP, 115/230V models must have a dedicated power circuit rated for at least 20A, 125V when they are wired for 115V. It is not unusual for these models to draw up to 20 amps at 115V when lifting at rated capacity. Refer to Table 3 before installation.

NOTE: It is recommended to use 230V on 115/230V models to reduce problems with low voltage and high amperage.

APPLICATION INFORMATION

This hoist is intended for general industrial use for lifting and transporting freely suspended material loads within its rated capacity. Little Mule cannot be responsible for applications other than those for which Little Mule equipment is recommended. Prior to installation and operation, we caution the user to review his application for abnormal environmental or handling conditions and to observe the applicable recommendations as follows:

ADVERSE ENVIRONMENTAL CONDITIONS

Do not use the hoist in areas containing flammable vapors, liquids, gases or any combustible dusts or fibers. Refer to Article 500 of the National Electrical Code. Do not use this hoist in highly corrosive, abrasive or wet environments. Do not use this hoist in applications involving extended exposure to ambient temperatures below -10°F or above 130°F.

LIFTING OF HAZARDOUS LOADS

This hoist is not recommended for use in lifting or transporting hazardous loads or materials which could cause widespread damage if dropped. The lifting of loads which could explode or create chemical or radioactive contamination if dropped requires fail-safe redundant supporting devices which are not incorporated into this hoist.

LIFTING OF GUIDED LOADS

This hoist is not recommended for use in the lifting of guided loads, including dumbwaiters and elevators. Such applications require additional protective devices which are not incorporated into this hoist. For such applications, refer to the requirements of applicable state and local codes, and the American National Safety Code for elevators, dumbwaiters, escalators and moving walks (ASME A17.1).

WARNING

Failure to comply with safety precautions outlined throughout this manual can result in serious injuries or death. Before using this hoist, each operator should become thoroughly familiar with all warnings, instructions and recommendations in this manual.

SAFETY INFORMATION

1. Follow all local electrical and safety codes, as well as the National Electrical Code (NEC) and the Occupational Safety and Health Act (OSHA) in the United States.
2. Hoist must be securely and adequately grounded. The hoist power cable is provided with an additional lead (green) for grounding purposes.
3. Be careful when touching the exterior of an operating motor; it may be hot enough to be painful or cause injury. With modern motors this condition is normal if operated at rated load and voltage (modern motors are built to operate at higher temperatures).

WARNING

Always disconnect the power source before working on or near a hoist or its connected load. If the power disconnect point is out of sight, lock it in the open position and tag to prevent unexpected application of power.

4. Protect the power cable and control cable from coming in contact with sharp objects.
5. Do not kink power cable and control cable and never allow the cable to come in contact with oil, grease, hot surfaces, or chemicals.
6. Make certain that the power source conforms to the requirements of your equipment.
7. Inspect the unit daily before operating hoist.
8. Cluttered areas and benches invite accidents.
9. The operator should not engage in any practice which will divert his attention while operating the hoist.
10. Before using the hoist, the operator should be certain that all personnel are clear.
11. Do not operate hoist with loads exceeding its rated capacity.
12. Supporting frames or beams used as a hoist hanger must have a greater load capacity than the hoist.
13. Do not attempt to operate hoist beyond normal maximum lift range.
14. Align hoist for a straight line pull. Avoid side pull or end pull.
15. Do not operate hoist with twisted or damaged chain.
16. Do not operate a damaged or malfunctioning hoist until necessary adjustments or repairs have been made.
17. Do not use hoist to lift people or to carry loads over people.
18. Do not leave a load suspended in the air unattended.
19. Always remove load before making repairs.
20. Do not remove or obscure capacity or warning decals.

INSTALLATION

1. Before installing the hoist, check the following:
 - a. Make sure all supporting structures and attaching devices are strong enough to hold your intended loads. If in doubt, consult a qualified structural engineer.
 - b. Provide proper branch circuit protection for the hoist as recommended in the National Electrical Code.
 - c. The power supply should be within plus or minus 10% of the voltage specified on the motor nameplate. It is critical to use adequate sized power cables, especially with 1-phase hoists (See Table 3, page 11). Be sure dual voltage hoists are connected or wired to correspond with your power supply (See WIRING, page 9).
 - d. Installation area must provide operating conditions for the operator including sufficient room for the operator and other personnel to stand clear of the load at all times.
 - e. For installations where the slack chain hanging from the unit may be objectionable or hazardous, the use of a chain container is recommended. See CHAIN CONTAINER, page 5.



2. Before operating the hoist, be sure to observe the following:
 - a. ALWAYS DISCONNECT HOIST FROM POWER SUPPLY before removing electrical cover or when making any electrical connection in the hoist or pushbutton station.
 - b. The ground wire (green colored) of the power cable should always be connected to a suitable ground by means of a screw or clamp. An alligator clip does not make a safe ground connection.
 - c. When installing a three-phase hoist, make only temporary connections at the power source. Push the "UP" button and observe the direction of the load block. If it raises, the phasing is correct and permanent connections may be made at the power source. If the load block lowers when the "UP" button is pushed, release the button immediately since the limit switches will not operate to protect the hoist from over-travel. Reverse any two wires (except the green ground wire) at the power source to correct the load hook direction (phasing). Do not change connections in the hoist or pushbutton assembly.
 - d. Make sure load chain is not twisted as it travels into the hoist.
 - e. Operate hoist in a hanging position only. Hoist should be permitted to align itself for a straight line pull. Do not attempt to pull around corners.
 - f. Read ASME-B30.16 Safety Code for Hoists.
3. If necessary, lubricate the chain, see LUBRICATION, page 10.
4. Check the function of the limit switches. Before placing hoist in operation, check limit switch adjustment. Operate pushbutton until near stop point and inch into stop limit both top and bottom. If either switch is not correct, adjust according to LIMIT SWITCH ADJUSTMENT, page 8.

Available chain containers include the standard metal containers designed for lifts of up to 50 ft on single-chained hoists and 25 ft on double-chained hoists. For longer lifts, the JL927-5 metal container is available. For applications where a fabric bag is preferred, the JL927-20F, JL927-40F and the JL927-70F are all options.

⚠ CAUTION

Do not attempt to store more chain in chain container than that specified in the table below or serious damage to hoist may result and hazardous conditions may be created.

Instructions are provided with each of these chain containers and must be adhered to closely to ensure a proper installation. To install the long lift chain container or a fabric chain container, you must follow instruction sheets 679J89 and 679J96 respectively. The following instructions are for the standard metal chain containers only.

INSTALLATION OF STANDARD METAL CHAIN CONTAINERS (JL927-1, JL927-3 and JL927-4)

Refer to Figure 1.

1. Remove dead end screw and washers and let chain hang free.
2. Place chain container bracket flush against housing. Replace washers and screw. Tighten securely.
3. Attach chain container to bracket with two open links and then close the links.

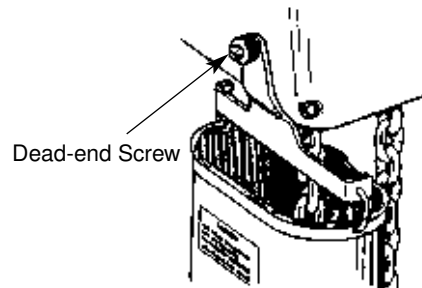

Figure 1 — Installing Standard Metal Chain Container

CHAIN CONTAINER (Optional Accessory)

Refer to Table 2.

For installations where the slack chain hanging from the hoist may be objectionable or hazardous, the use of a chain container is recommended.

Table 2 - Optional Chain Containers

Chain Container Model	Recommended for Use With: Hoist Capacity	Maximum Lift (ft)	Container Material	Dimensions in Inches		
				Width	Length	Depth
JL927-1	1 Ton & Under	20	Steel (.036" thick)	3	6½	11½
	2 Ton	10				
JL927-3	1 Ton & Under	35	Steel (.036" thick)	3	6½	18½
	2 Ton	17				
JL927-4	1 Ton & Under	50	Steel (.036" thick)	3	6½	27
	2 Ton	25				
JL927-5	1 Ton & Under	143	Steel (.06" thick)	6	8	34
	2 Ton	71				
JL927-20F	1 Ton & Under	20	Open Weave Vinyl Coated Polyester	7½	7½	10
	2 Ton	10				
JL927-40F	1 Ton & Under	40	Open Weave Vinyl Coated Polyester	7½	7½	16
	2 Ton	20				
JL927-70F	1 Ton & Under	70	Open Weave Vinyl Coated Polyester	7½	7½	20
	2 Ton	35				

4. Run load hook down to its lowest position. Place the slack end of chain in chain container. Feed the remainder of chain into container by operating hoist in the "UP" direction to the top limit. This will allow the chain to pile freely without kinking, which occurs when you place the chain in the container by hand.

CAUTION

Do not allow load to come in contact with chain container. If this situation exists reset the "UP" limit switch (See LIMIT SWITCH ADJUSTMENT, page 8) so that hook block stops below chain container.

OPERATION

This hoist is designed for safe operation within the limits of its rated capacity. It is controlled with the "UP" and "DOWN" buttons of the pushbutton station. Although the Little Mule FEL is built with many features to ensure safety, it is a requirement that a hoist operator understands safe lifting practices. The following points must be observed.

1. Do not overload the hoist.
2. Do not make extreme side pulls with the hoist.
3. Operate the hoist only in a hanging position with adequate support.
4. Do not "sling" the load hook and chain around the load. Use an approved sling.
5. Be sure there are no twists in the load chain as it travels into the hoist housing. This condition should be constantly checked on double chain hoists because it is possible for the load block to be "capsized" or turned over one or more times.
6. Before raising a load, always check to see that it is held securely in the hook or sling chains, etc. Raise the load only until the load chain is taut and then double check the rigging before continuing to raise the load.
7. Do not stand beneath a load! Do not move a load in such a manner as to endanger personnel.
8. Do not lower into areas where visibility is obscured unless someone else is guiding the operation.

WARNING

Do not use hoist to lift, support or otherwise transport people.

9. Use common sense at all times when operating a hoist.
10. Do not operate if direction of hook travel is not the same as indicated on button being pushed.
11. Do not operate unless hook travel limit devices function. Test without load each shift.
12. Do not operate when hoist is not centered over load.
13. Do not operate if chain is not seated properly in sprockets or sheave grooves.
14. Do not operate damaged or malfunctioning hoist.

OVERLOAD LIMITING PROTECTION

This hoist is equipped with a factory-calibrated overload limiting clutch that will permit the lifting of loads within its rated capacity, but will prevent the lifting of damaging overloads while the hoist is being operated. If the load being lifted exceeds the lifting capability of the overload clutch, the hoist motor will continue to run, causing overheating of both the clutch and hoist motor. This condition should be avoided by immediately releasing the "UP" button and reducing the load to within the rated capacity of the hoist. See GEARING, page 11, for additional instructions on this device.

CAUTION

The overload limiting clutch is an emergency protective device and should not be used to measure the maximum load to be lifted, or to sense the overload imposed by a constrained load. While the overload limiting clutch will protect the hoist from damaging overloads, it will not ensure that a load is within the rated capacity of the hoist.

MAINTENANCE

INSPECTIONS

A planned inspection routine should be established for this hoist based upon frequency of use, severity of use, and environmental conditions, (Reference ASME Standard B30.16). Some inspections should be made frequently (daily to monthly) and others periodically (monthly to yearly). It is strongly recommended that an Inspection and Maintenance Check List and an Inspector's Report, similar to those shown in Figures 10A and 10B, be used and filed for reference. All inspections should be performed or overseen by a designated inspector. Special inspections should be made following any significant repairs or any operating occurrence leading one to suspect that the hoist's capability may have been impaired.

LOWERING WITHOUT POWER

If the power fails with a load suspended, the hoist will automatically stop. In an emergency the load can be lowered without power as follows:

1. DISCONNECT HOIST FROM POWER SUPPLY AND REMOVE ELECTRICAL COVER.
2. Refer to Figure 6. Open disc brake manually by using two screwdriver blades, one on each side of the brake at a point close to the brake spring posts. Apply pressure to the underside of the armature plate (points "X") to close the solenoid and release the brake.

WARNING

Do not allow screwdriver blades to touch rotating friction disc "C".



CAUTION

Do not allow the load to descend rapidly. This causes the motor to race and serious damage may result.

- Use several quick releases instead of holding brake open continuously. Do not exceed normal lowering speed.

HOOKS

Refer to Figure 2.

- Inspect hooks once daily for cracking, extreme wear or spreading. Replace hooks showing any of these signs. If the throat openings are spread wider than the maximum permissible 15% increase listed here, the hooks have been overstressed and must be replaced. Any hook that is bent or twisted more than 10° from the plane of an unbent hook must also be replaced.
- The hook latches should be inspected to ensure that they close the hook throat opening in a secure manner when a load is applied. Inspect the hook shank and nut for any stripping of the threads or other damage. The hook nut should be fully restrained by the retaining pin.
- In addition to above, load hooks should be inspected for cracks by the magnetic particle, dye penetrant or other suitable crack testing inspection method. This should be done at least once a year.

Hoist Capacity	"X" Dimension*	
	Top Hook	Bottom Hook
1 Ton & Under	1 ¹¹ / ₃₂ "	1 ⁷ / ₃₂ "
2 ton	1 ¹¹ / ₃₂ "	1 ¹¹ / ₃₂ "

(*) Maximum permissible throat opening of hook.

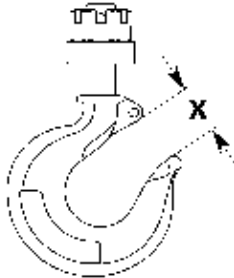

Figure 2 — Hook Inspection

CHAIN

Chain is to be kept clean and lubricated. (See LUBRICATION, page 10). Visually check chain every time hoist is used. Hoist must not be operated when chain is twisted or kinked. An important phase of hoist maintenance is chain inspection. Check individual links and check for chain elongation.

- Check the chain for overall wear or stretch by selecting an unworn, unstretched length of chain (at the slack end for example). Let the chain hang vertically with a light load (about 20 pounds) on the chain to pull it taut. Use a large caliper to measure the outside length of a convenient number of links (about 12"). Measure the same number of links in a used section of chain and calculate the percentage increase in length of the worn chain.

- If the length of the worn chain is more than 1½% longer than the unused chain (0.015" per inch of chain measured), then the chain should be replaced. If the chain is worn less than 1½%, check it at several more places along its length. If any section is worn more than 1½%, the chain should be replaced.

CAUTION

The chain used on this hoist has very carefully controlled dimensions and has been heat treated. Do not attempt to substitute other manufacturer's chain.

Chain Replacement with Chain in Hoist

Refer to Figures 3 and 4.

- Run hook up to its top limit.
- DISCONNECT HOIST FROM POWER SUPPLY and remove the electrical cover.
- Using a screwdriver, pry the spring guide plate out of the slots in the limit switch nuts (See Figure 3). Turn the gold nut back to about the center of the threaded screw. Do not disconnect the wires from the limit switches.
- Remove the load block assembly from the old chain. On double-chained hoists detach the chain from the chain support and pull it through the load block assembly (See Figure 4).
- Make a "C" shaped chain link by grinding through the end link on the load end of the old chain.
- Using the "C" link, attach the new chain to the load end of the old chain. Be sure that the welds of the upstanding links of the new chain will face outward from the load sheave. The end links must be oriented for attachment to the dead-end screw and the chain support (double-chained only) without any twist in the chain.
- With the electrical cover off, connect the hoist to the power supply. Be sure that the green ground wire is properly grounded (See INSTALLATION, page 4).
- Carefully jog the "UP" button and run the joined pieces of chain into the hoist until about 15" of the new chain comes out the other side.
- DISCONNECT HOIST FROM POWER SUPPLY.
- Remove the "C" link and the old chain. Remove the chain stop from the old chain by prying off its retaining ring with a flathead screwdriver. If attached, remove the old chain from the side of the hoist by removing the dead-end screw and washers (note placement of washers).

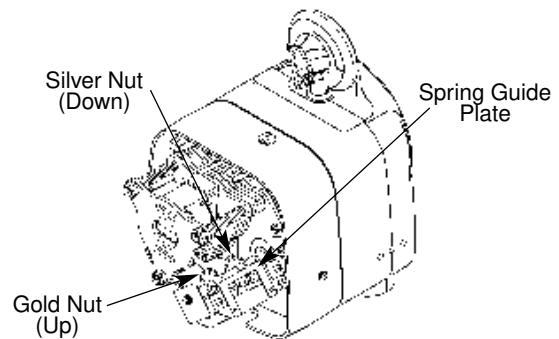

Figure 3 — Limit Switch Assembly

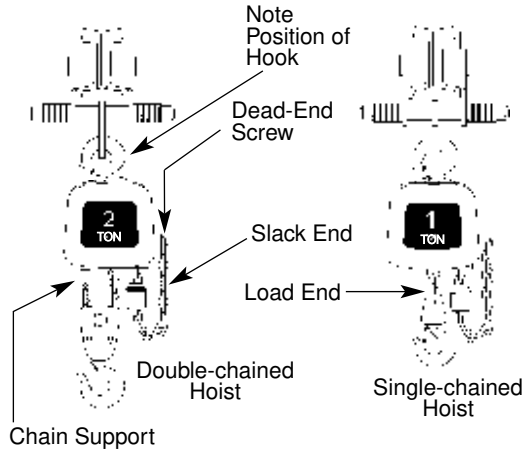

Figure 4 — Chain Replacement Diagram

11. Attach the chain stop to the slack end of the new chain by capturing the 12th link with the two stop halves positioned with their tapered ends pointing towards the hoist. Slide the sleeve over the halves and attach the retaining ring. If you are not using a chain container, attach the slack end of the new chain to the side of the hoist using the dead-end screw and washers. With factory supplied hardware there should be six washers between the hoist and chain link and two washers between the chain link and screw head. **DO NOT** allow twists in the chain.
12. Adjust the lower limit switch (See ADJUSTING LOWER LIMIT, page 9).
13. Attach the bottom block on single-chained hoists using a new load block screw or pin (See Figure 21). On double-chained hoists, feed the chain through the load block (welds of the upstanding links will be in towards the sheave) and fasten the end of the chain to the chain support using a new chain support pin (See Figure 21). Be sure there are no twists in the chain.
14. Adjust the upper limit switch (See ADJUSTING UPPER LIMIT, page 8).

Chain Replacement with No Chain in Hoist

Refer to Figures 4 and 5.

1. DISCONNECT HOIST FROM POWER SUPPLY and move hoist to a work table. Do not remove the electrical cover.
2. Lay the hoist on its side and remove the four screws that attach the sheave housing to the gear housing (See Figure 12, Ref. No. 2).
3. Carefully pull the sheave housing and motor assembly loose from the gear housing.

CAUTION

There are wires running through the hoist. Carefully ease the hoist sections apart. Do not jerk them apart.

4. Turn the two hoist sections at right angles and remove the chain guide screws and the nearest chain guide (Ref. No. 1, Figure 5).
5. Remove the two chain guide plate screws (Ref. No. 2) and the nearest chain guide plate. Be careful not to lose the two spacers that are between the chain guide plates.

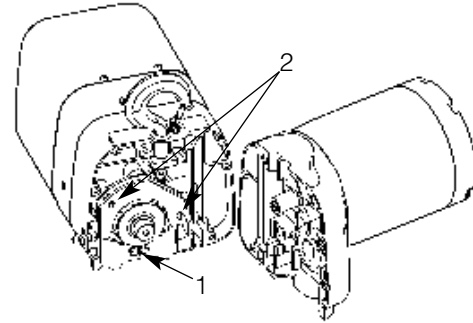

Figure 5 — Chain Replacement with No Chain in Hoist

NOTE: Inspect chain guides and load sheave for wear, replace as needed.

6. Lay the new chain over the load sheave. Allow about 15" of chain below the hoist on the slack end (See Figure 4). Be sure the welds of the upstanding links are out away from the load sheave and that proper orientation is observed for attachment of the dead end. Also be sure the load hook assembly (if already attached to the chain) is toward the center of the hoist or to your right as you face the load sheave.
7. Replace the chain guide plate and the chain guide. Grease the splined shafts that project from both the housing and the motor.
8. Place the motor coupling on the splined shaft and carefully fit the two hoist sections together. Be sure the dead-end nut, the top hook and the chain support (double-chained hoists only) are all in place. On single-chained hoists, the hook shank goes in the center hole; on double-chained hoists, it goes in the off-center hole (See Figure 4). Be careful not to pinch any of the wiring. Turn the hoist on its side and replace the four screws and tighten securely.
9. Follow steps 11 through 14 in the previous section, CHAIN REPLACEMENT WITH CHAIN IN HOIST, to complete the chain replacement procedure.

LIMIT SWITCH ADJUSTMENT

IMPORTANT: Before placing hoist in operation, check the limit switch adjustment. Limit switches are provided to protect the hoist against damage resulting from overtravel or to allow setting the hook travel within the factory-set limits of travel. The standard limit switch is designed for lifts of 50 ft or less on single-chained hoists and 25 ft or less on the 2 ton, double-chained models. The long lift limit switch allows for the maximum amount of lift, which is 134 ft on 1/4 and 1/2 ton hoist models, 143 ft on the 1 ton models, and 71 ft on the 2 ton models.

The upper and lower limit switch adjusting nuts are color-coded gold and silver respectively. Each limit nut has 10 slots for fine adjustment, and the increment of adjustment is such that one slot is equivalent to approximately one link of chain travel. Movement of the limit switch nuts toward or away from each other increases or decreases the hook travel respectively.

Adjusting Upper Limit (Gold Nut)

Refer to Figure 3.

1. Suspend the hoist. For single-chained models raise the load block until there is a minimum clearance of 2" from the hoist housing and the top of the block. Double-chained models require a minimum clearance of 1" from the chain support to the top of the load block.



2. DISCONNECT HOIST FROM POWER SUPPLY and remove the electrical cover.
3. With a screwdriver, pry the spring guide plate out of the slots in the limit switch nuts.
4. Turn the slotted gold nut toward its limit switch until the switch "clicks" then turn two slots farther. Release the spring guide plate and be sure it slips back into the slots in both limit switch nuts. Do not disturb the silver slotted nut if it has been set previously.

Adjusting Lower Limit (Silver Nut)

Refer to Figure 3.

1. Suspend the hoist. Carefully lower the load block to a point where the slack-end loop of the chain hangs down 6" or more from the hoist housing (or the limit desired in any particular application allowing the minimum 6"). There should be a minimum clearance of 1½" between the chain stop and the bottom of the hoist.
2. DISCONNECT HOIST FROM POWER SUPPLY and remove the electrical cover.
3. With a screwdriver, pry the spring guide plate out of the slots in the limit switch nuts.
4. Turn the slotted silver nut toward its limit switch until the switch "clicks," then turn two slots farther. Release the spring guide plate and be sure it slips back in the slots in both limit switch nuts. Do not disturb the gold slotted nut if it has been set previously.

CAUTION

If the wires running to the limit switches are ever disconnected for any purpose, be sure to replace wires in accordance with the correct wiring diagram (See Figures 9A and 9B).

Check Both Upper and Lower Limits

1. Connect the hoist to the power supply. Be sure the green ground wire is properly grounded .
2. Check load hook direction (See INSTALLATION 2c, page 5).
3. Carefully raise load block to upper limit and observe if it stops automatically at desired level. Do not allow load block to run into hoist housing — this will damage the hoist. Maintain a minimum clearance of 2" from the hoist housing and the top of the load block on single-chained models and 1" from the chain support to the top of the load block on double-chained models.
4. Carefully lower load block to lower limit and observe if it stops automatically at the desired level. Do not allow slack-end loop of chain to become taut against hoist housing. This will damage the hoist. There should be a minimum clearance of 1½" between the chain stop and the bottom of the hoist.
5. If upper and lower limits operate satisfactorily, hoist is ready for use. If they are not as desired, repeat adjustment.

BRAKE

Properly adjusted, this brake will release promptly when energized. It is capable of both smoothly stopping and securely holding the rated capacity of the lifting motor. If the lifting motor develops either undesirable over-travel after a pushbutton is released (this condition is most noticeable in the lowering direction) or hesitates to lift the load promptly, the brake should be adjusted.

Brake Adjustment

Refer to Figure 6.

1. DISCONNECT HOIST FROM POWER SUPPLY and remove the electrical cover.

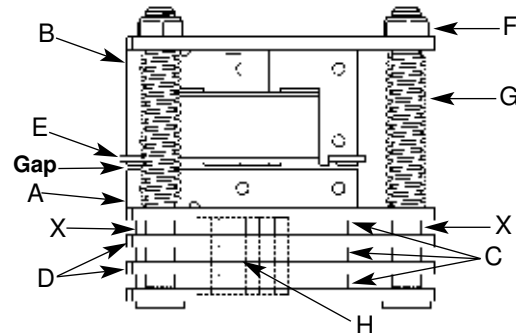

Figure 6 — Brake Assembly

2. With reference to Figure 6, the gap between the brake armature "A" and the field "B" should be checked. The correct gap is 0.015". Adjustment should not be necessary until gap reaches 0.040".
3. Adjust the gap using a 9/16" socket on the 3 locknuts "F". Check with a feeler gauge to be sure the gap is the same on both ends of the solenoid.
4. Adjustment is now complete and the brake properly set. Replace the electrical cover, reconnect the power supply, and check hoist brake action.

CAUTION

Be sure the bottom of the armature does not bear against the splined adapter "H". As adjustments are made, the built-in clearance will be reduced. When this clearance is gone REPLACE BRAKE DISCS. Minimum allowable disc thickness is .162". See Figure 15 for further illustration.

HOIST CONTROLS

Both the pushbutton and the reversing contactor are mechanically interlocked to prevent shorting the circuit and causing serious damage. As part of maintenance, always check for proper closure of contact points as well as for burned contacts. If replacement is necessary, see Figures 16 & 17 for replacement parts.

WIRING

Refer to Figures 9A and 9B

Little Mule electric chain hoists, which are available for 115/230V or 230/460V, are shipped wired for 115V and 460V respectively. Conversion of dual voltage hoists to either the higher or lower voltage can be done simply and quickly as follows:

1. DISCONNECT HOIST FROM POWER SUPPLY and remove the electrical cover.
2. Each dual-voltage hoist has a terminal block assembly for the interconnection of the electrical components of the hoist. To convert the voltage, reconnect the leads to the terminal blocks according to the wiring diagram located inside the electrical cover or Figures 9A and 9B.

DO NOT move any wires or make any changes to the electrical circuit except at the terminal block assembly. Tug on wires to ensure they are securely connected.

3. After converting the voltage, recheck phasing and limit switch operation (See INSTALLATION 2-c & 4, page 5).

IMPORTANT: Always refer to the wiring diagram located on the inside of the electrical cover or Figures 9A and 9B when performing electrical repairs. Make sure all connections are secure and check for damaged insulation. It is also imperative that the power circuit has conductors of adequate size (See Table 3).

LUBRICATION

Refer to Figure 11.

Proper lubrication is necessary to ensure a long and reliable hoist life. Refer to the following and the RECOMMENDED LUBRICATION SCHEDULE for lubrication points, type of lubricant, and frequency of lubrication.

Load Chain

Clean the load chain with acid-free solvent and coat with SAE 90 gear oil. Wipe excess oil to prevent dripping. Never apply grease to the chain.

Gearing

The gear case of this hoist is filled at assembly with 1½ pints of SAE 90 EP gear oil. Check oil level by removing the oil level check plug from the side of the hoist. With the hoist hanging level, the gear oil should be even with the hole.

Bearings

All bearings except hook and idler sheave bearings are lubricated at the factory and should not require additional lubrication. Noisy or worn bearings should be replaced.

Limit Switch Shaft

Remove any dirt accumulation and spray with a general purpose lubricant.

Hook Bearing

Apply a few drops of SAE 30 gear or motor oil around the edge of the bearing.

Idler Sheave Bearing (Bushing)

Disassemble load block and apply a light coat of NLGI #2 grease, or equivalent, inside of bearing.

HOIST REPAIRS

NOTE: If you do not have an experienced mechanic to do your repair work, we recommend that you send your hoist to an approved service station for repairs. Use authorized repair parts only.

WARNING

Remove load and disconnect hoist from power supply before starting to do any repairs or to take any sections apart.

1. For major repairs or when the hoist is to be sectioned in the suspension area, it will be necessary to move the hoist to a workbench or table.

2. For repairs which can be done by removing the electrical cover only, the hoist need not be moved. Lowering the hoist to a convenient working level is desirable.

The following repair instructions will help you in understanding repair procedures, when related to the Replacement Parts List starting on page 17. For clarity these are broken down into areas.

Electrical Parts and Brake

1. Refer to Figure 16. Remove the cover to access the controls. Single-phase models also have a starting switch and capacitor mounted on the motor as shown in Figure 13. The terminal blocks and end clamps snap off of the rails on the plate using a small screwdriver. **DO NOT SLIDE THE END CLAMPS.**

The contactor can be slid off the rail, but must be snapped on. Where the contactor fits the rail, one side has springs or pads that apply pressure against the edge of the rail. By pressing against that side at the base of the contactor, you can snap the part on or off using a rotating action. Note the numbers that label the terminals on the contactor and orient the part as shown in Figures 9A & 9B. Single-phase contactors have a small jumper that is not present on the 3-phase (note the 3 and 5 terminals on the reversing contactor in Figure 9A).

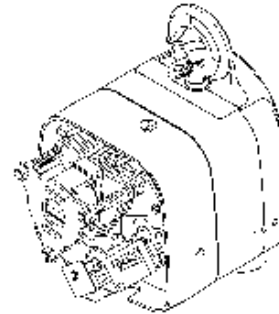

Figure 7 - Electrical Panel Removed

2. Remove the electrical panel by removing the stand-off screws (See Figure 16). The limit switch and brake are now accessible as shown in Figure 7.
3. Remove the transformer bolted to the back of the panel plate if it requires replacement.
4. Refer to Figure 15 to disassemble the brake. See BRAKE ADJUSTMENT on page 9 to properly set the brake.
5. Refer to Figures 18 and 19 to disassemble the limit switch. See LIMIT SWITCH ADJUSTMENT on page 8 to properly set the upper and lower limits of travel.
6. Refer to Figure 17 for repairs on the pushbutton station. Also refer to the wiring diagram inside the electrical cover or Figures 9A & 9B for wiring instructions.

Motor

Refer to Figures 12, 13, and 14.

The hoist motor is located on the opposite end to that of the electrical parts, but the two are tied together with electrical leads running through the housing.

1. If it is necessary to replace or repair the motor, **DISCONNECT THE HOIST FROM THE POWER SUPPLY** and remove the electrical cover.
2. Loosen the screw clamps on the terminal blocks and reversing contactor to disconnect the motor leads (See Figure 16).



3. Remove the four motor mounting bolts attaching the motor to the housing. It will come loose at the motor coupling.
4. Inspect the motor coupling, motor shaft and all the bearings. Replace as necessary.
5. Install new or repaired motor according to the wiring diagram located inside the electrical cover or Figures 9A and 9B.

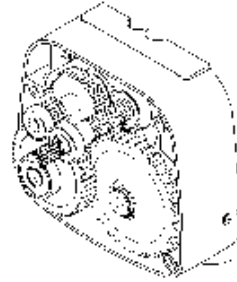

Gearing

Refer to Figures 8, 12 and 20.

As disassembly is extensive for gearing, disconnect the hoist and move it to a workbench.

1. Remove electrical cover.
2. Remove electrical panel.
3. Remove brake assembly and limit switch assembly.
4. Drain oil from transmission.
5. Remove the four screws attaching the gear box cover to the gear housing and remove the gear box cover. The limit switch drive shaft will come along with the cover.
6. Inspect gears for broken or severely worn teeth and inspect all bearings. Replace as necessary. The overload slip clutch is factory calibrated and must not be disassembled or readjusted.

Figure 8 - Assembled Gearing

Suspension

Use the Parts List for Basic Hoist and Chaining Parts to help in repairs in this section (See Figures 12 and 21). The hoist sections must be separated at the top hook line in order to inspect the load sheave and chain guides. See CHAIN REPLACEMENT WITH NO CHAIN IN HOIST, page 8.

While this section is apart, check the following:

- Load sheave
- Chain guides and plates
- Chain
- Chain support (on 2 ton models)
- Bearings

Replace parts as necessary including screws, lockwashers, etc.

When reassembled, recheck limit switch operation. See LIMIT SWITCH ADJUSTMENT, page 8.

CAUTION

Do not disassemble or readjust clutch, or replace with a clutch assembly from another hoist. Doing so will void the warranty and may create an unsafe condition. If replacement is needed due to wear or loss of adjustment, always use a new clutch assembly.

7. Reassemble in reverse order of disassembly making sure the gasket is in place and in good condition. Coat gasket with Permatex® or other gasket cement. Extreme care should be taken to avoid damage to oil seals.
8. Check all wire terminals to be sure they are properly seated and in accordance with wiring diagram. Before placing hoist back into service, check brake adjustment and limit switch stops.

POWER SUPPLY PRECAUTIONS WITH 1-PHASE HOISTS

Electric hoists require a sufficient power supply. It is especially important with single-phase voltage to ensure that the conductors running to the hoist from the power source are adequate in size to handle the power requirements of the hoist. Inadequate **power cables** and **branch circuits** will cause low voltage, high amperage, damage to the hoist, and potential fire hazards. Such problems can be minimized by using 230V power on 115/230V hoists. The following are recommendations for the conductor gage size depending on the length, horsepower, and voltage.

Table 3 - Recommended Conductor Sizes for 1-Phase Hoists

HP	Voltage (1-Phase)	Maximum Conductor Length in Feet			
		14 AWG	12 AWG	10 AWG	8 AWG
1/4	115V	75	120	190	300
	230V	350	560	900	
1/2	115V	40	60	100	150
	230V	200	330	520	810
1	115V	0	30	50	75
	230V	120	190	310	490



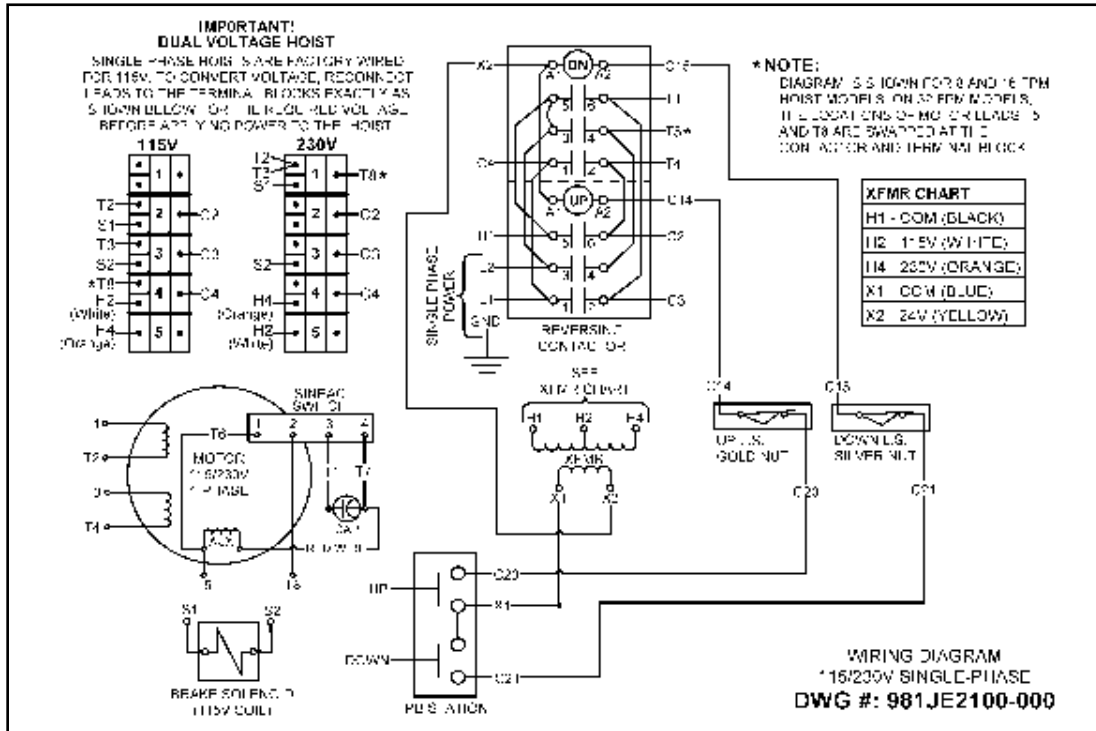

Figure 9A — Wiring Diagram for 1-Speed, 1-Phase Models

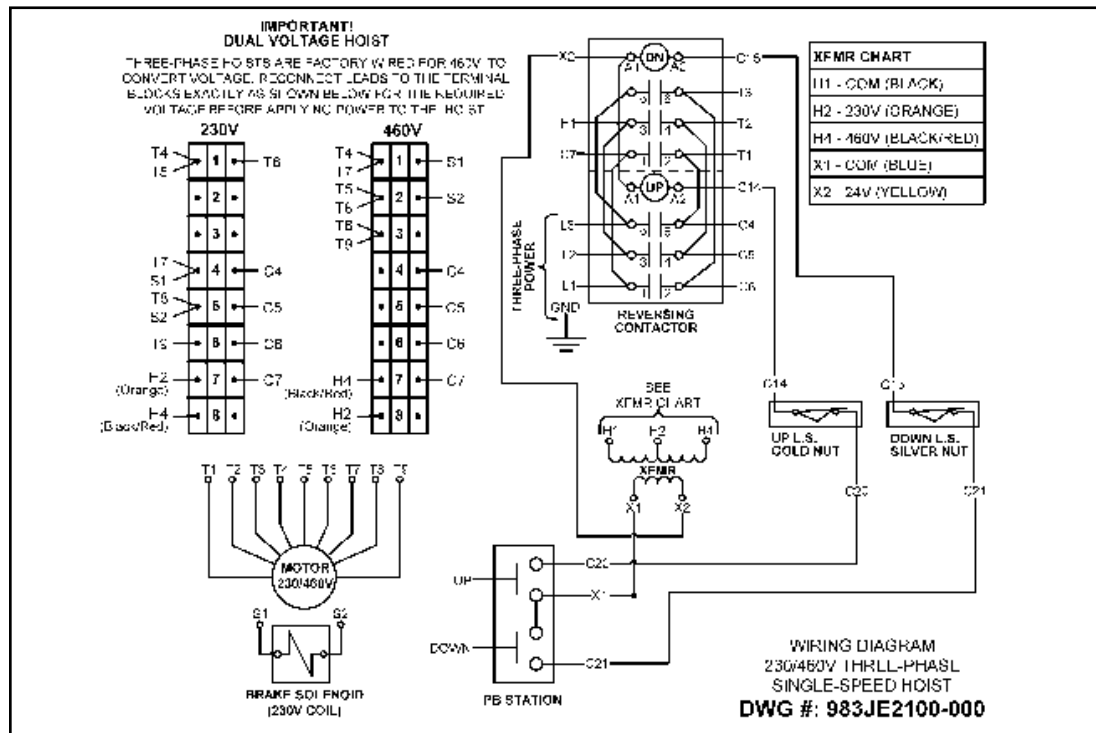
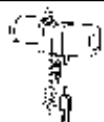

Figure 9B — Wiring Diagram for 1-Speed, 3-Phase Models



TROUBLE SHOOTING

Always disconnect unit from the power supply system before removing hoist covers or the back cover of control station.

— Probable Cause —

— Remedy —

Hook fails to stop at end of travel	
<ol style="list-style-type: none"> 1. Limit switch not operating 2. Brass limit switch nuts not moving on shaft 3. Hoist reversing contactor malfunctioning 	<ol style="list-style-type: none"> 1. Check adjustment (See LIMIT SWITCH ADJUSTMENT, page 8). Check connections against wiring diagram. Tighten loose connections or replace. 2. Check for stripped threads or bent nut guide. 3. Remove electrical cover and check reversing contactor.
Hoist does not respond to pushbutton	
<ol style="list-style-type: none"> 1. Power failure in supply lines 2. Wrong voltage or frequency 3. Improper connections in hoist or pushbutton station 4. Brake does not release 5. Faulty hoist reversing contactor 	<ol style="list-style-type: none"> 1. Check circuit breakers, switches and connections in power supply lines. 2. Check voltage and frequency of power supply against the rating on the nameplate of the motor. 3. Check all connections at line connectors and on terminal block. Check terminal block on dual voltage hoists for proper voltage connections. 4. Check connections to the solenoid coil. Check for open or short circuit. Check for proper adjustment (See BRAKE ADJUSTMENT, page 9). 5. Check coils for open or short circuit. Check all connections in control circuit. Check for burned contacts. Replace as needed.
Hook does not stop promptly	
<ol style="list-style-type: none"> 1. Hoist overloaded 2. Brake not holding 	<ol style="list-style-type: none"> 1. Reduce load to within rated capacity of hoist. 2. Check brake adjustment (See BRAKE ADJUSTMENT, page 9). It may be necessary to replace discs.
Hook moves in wrong direction	
<ol style="list-style-type: none"> 1. Three phase reversal 2. Improper connections 	<ol style="list-style-type: none"> 1. Reverse any two wires (except the green ground wire) at the power source (See INSTALLATION 2c, page 5). 2. Check all connections against wiring diagram.
Hoist hesitates to lift when energized	
<ol style="list-style-type: none"> 1. Hoist overloaded 2. Motor brake requires adjustment 3. Worn overload limiting clutch 4. Low voltage 5. Faulty SINPAC® starting switch or start capacitor (single phase hoists only) 	<ol style="list-style-type: none"> 1. Reduce load within rated capacity of hoist. 2. Check motor brake adjustment (See BRAKE ADJUSTMENT, page 9). 3. Replace clutch. 4. Determine cause of low voltage and bring up to within plus or minus 10% of the voltage specified on the motor. Measure voltage at the hoist reversing contactor while lifting a load. 5. Replace faulty component.
Hook raises but will not lower	
<ol style="list-style-type: none"> 1. "DOWN" circuit open 2. Broken conductor in pushbutton cable 3. Faulty hoist reversing contactor 	<ol style="list-style-type: none"> 1. Check circuit for loose connections. Check "DOWN" limit switch for malfunction. 2. Check each conductor in the cable. If one is broken, replace entire cable. 3. Check coils for open or short circuit. Check all connections in control circuit. Check for burned contacts. Replace as needed.
Hook lowers but will not raise	
<ol style="list-style-type: none"> 1. Hoist overloaded 2. Low voltage 3. "UP" circuit open 4. Broken conductor in pushbutton cable 5. Faulty hoist reversing contactor 6. Faulty capacitor (single phase hoist only) 7. Worn overload limiting clutch 8. Loose screw clamps 	<ol style="list-style-type: none"> 1. Reduce load to within rated capacity of hoist. 2. Determine cause of low voltage and bring up to within plus or minus 10% of the voltage specified on the motor. Measure voltage at the hoist reversing contactor while lifting a load. 3. Check circuit for loose connections. Check "UP" limit switch for malfunction. 4. Check each conductor in the cable. If one is broken, replace entire cable. 5. Check coils for open or short circuit, check all connections in control circuit. Check for burned contacts. Replace as needed. 6. Check starting capacitor on motor. Replace if necessary. 7. Replace overload clutch assembly. 8. Ensure that screw clamps are tightened on the terminal blocks and reversing contactor.
Motor overheats	
<ol style="list-style-type: none"> 1. Excessive load 2. Low voltage 3. Extreme external heating 4. Frequent starting or reversing 5. Brake dragging 	<ol style="list-style-type: none"> 1. Reduce load to within rated capacity of hoist. 2. Determine cause of low voltage and bring up to within plus or minus 10% of the voltage specified on the motor. Measure voltage at the hoist reversing contactor while lifting a load. 3. As the ambient temperature rises towards the 130°F limitation of the unit, frequency of the hoist operation must be limited to avoid overheating of the motor. See ADVERSE ENVIRONMENTAL CONDITIONS, page 4. 4. Excessive inching, jogging or reversing should be avoided since this type of operation will drastically shorten the life of motor, contactor and brake. 5. Check brake adjustment (See BRAKE ADJUSTMENT, page 9).
Lack of proper lifting speed	
<ol style="list-style-type: none"> 1. Hoist overloaded 2. Brake dragging 3. Low voltage 4. Overload limiting clutch intermittently slipping 	<ol style="list-style-type: none"> 1. Reduce load to within rated capacity of hoist. 2. Check for proper brake adjustment or other defects. 3. Ensure that the voltage at the reversing contactor is within ±10% of the nominal voltage while lifting a load. 4. Replace overload clutch assembly.

TROUBLE SHOOTING (Continued)

Motor brake noise or chatter (while starting hoist)

- | | |
|---|---|
| 1. Brake needs adjustment
2. Low voltage | 1. See BRAKE ADJUSTMENT, page 9.
2. Ensure that the voltage at the reversing contactor is within $\pm 10\%$ of the nominal voltage while lifting a load. |
|---|---|

Motor brake "buzz" (anytime hoist is running)

- | | |
|--|---|
| 1. Brake needs adjustment
2. Broken shading coil on brake frame | 1. See BRAKE ADJUSTMENT, page 9.
2. Replace shading coil or complete brake frame assembly. |
|--|---|

INSPECTION AND MAINTENANCE CHECK LIST ELECTRIC POWERED OVERHEAD CHAIN HOIST

Type of Hoist _____ Capacity (Tons) _____
 Location _____ Original Installation Date _____
 Manufacturer _____ Manufacturer's Serial No. _____

Item	Frequency of Inspection			Possible Deficiencies	OK	Action Required
	Frequent		Periodic			
	Daily	Monthly	1-12 Mo.			
Operating Controls	*	*	*	Any deficiency causing improper operation		
Limit Switches	*	*	*	1. Any deficiency causing improper operation 2. Pitting or deterioration		
Brake Mechanism	*	*	*	1. Slippage or excessive drift 2. Glazing, contamination or excessive wear		
Hooks	*	*	*	Excessive throat opening 15% bent or twisted more than 10 degrees, damaged hook latch, wear, chemical damage, worn hook bearing. To find cracks, (use dye penetrant, magnetic or other suitable detection methods)		
Suspension Lug (if used)	*	*	*	Cracks, excessive wear or other damage which may impair the strength of the lug. To find cracks, (use dye penetrant, magnetic particle or other suitable detection methods)		
Chain	*	*	*	Inadequate lubrication, excessive wear or stretch, cracked, damaged or twisted links, corrosion or foreign substance		
Hook and Suspension Lug Connections			*	Cracks, bending, stripped threads		
Pins, Bearings, Bushings Shafts, Couplings			*	Excessive wear, corrosion, cracks, distortion		
Nuts, Bolts, Rivets			*	Looseness, stripped and damaged threads, corrosion		
Sheaves			*	Distortion, cracks, and excessive wear. Build-up of foreign substances		
Housings, Load Block			*	Cracks, distortion. Excessive wear, internal build-up of foreign substances		
Wiring and Terminals			*	Fraying, defective insulation		
Hoist Reversing Contactor, other Electrical Apparatus			*	Loose connections, burned or pitted contacts		
Supporting Structure and Trolley (if used)			*	Damage or wear which restricts ability to support imposed loads		
Nameplates, Decals, Warning Labels			*	Missing, damaged or illegible		

NOTE: Refer to Maintenance and Inspection Sections of the Hoist-Maintenance Manual for further details.

FREQUENCY OF INSPECTION

Frequent — Indicates items requiring inspection daily to monthly. Daily inspections may be performed by the operator if properly designated.

Periodic — Indicates items requiring inspection monthly to yearly. Inspections to be performed by or under the direction of a properly designated period. The exact period of inspection will depend on frequency and type of usage. Determination of this period will be based on the user's experience. It is recommended that the user begin with a monthly inspection and extend the periods to quarterly, semi-annually or annually based on user's monthly experience.

Figure 10A — Recommended Inspection and Maintenance Check List

NOTE: This inspection and maintenance check list is in accordance with our interpretation of the requirements of the Safety Standard for Overhead Hoists ASME B30.16. It is, however, the ultimate responsibility of the employer/user to interpret and adhere to the applicable requirements of this safety standard.



INSPECTOR'S REPORT			
ITEM	REMARKS (LIST DEFICIENCIES AND RECOMMENDED ACTION)		
Inspector's Signature	Date Inspected	Approved by	Date

Figure 10B — Recommended Inspector's Report

RECOMMENDED LUBRICATION SCHEDULE* LITTLE MULE ELECTRIC POWERED CHAIN HOIST					
FIGURE & REFERENCE NO.	COMPONENT	TYPE OF LUBRICANT	TYPE OF SERVICE AND FREQUENCY OF LUBRICATION		
			HEAVY	NORMAL	INFREQUENT
Figure 21 Ref. No. 18	Load Chain	SAE 90 gear oil	Daily	Weekly	Monthly
Figure 20	Gearing	SAE 90 extreme pressure (EP) gear oil	At periodic inspection (See Figure 10A)		
Figures 18 & 19 Ref. Nos. 9 & 7	Limit Switch Shaft	General purpose spray lubricant	Monthly	Yearly	Yearly
Figure 21 Ref. No. 38, 50	Load Hook Bearing	SAE 30 gear or motor oil	Weekly	Monthly	Yearly
Figure 21 Ref. No. 44	Idler Sheave Bearing (Bushing) Assembly	NLGI #2 multi-purpose lithium base grease	At periodic inspection (See Figure 10A)		

NOTE: All bearings except hook and idler sheave bearings are prelubricated and sealed.

(*) This lubrication schedule is based on a hoist operating in normal environment conditions. Hoists operating in adverse atmospheres containing excessive heat, corrosive fumes or vapors, abrasive dust, etc., should be lubricated more frequently.

Figure 11 — Recommended Lubrication Schedule



Contact your nearest Little Mule Service Center for parts and service. For a complete list, see pages 30 and 31. Please have the hoist model number, serial number, and part number with description available for reference.

Figure 12 - Basic Hoist

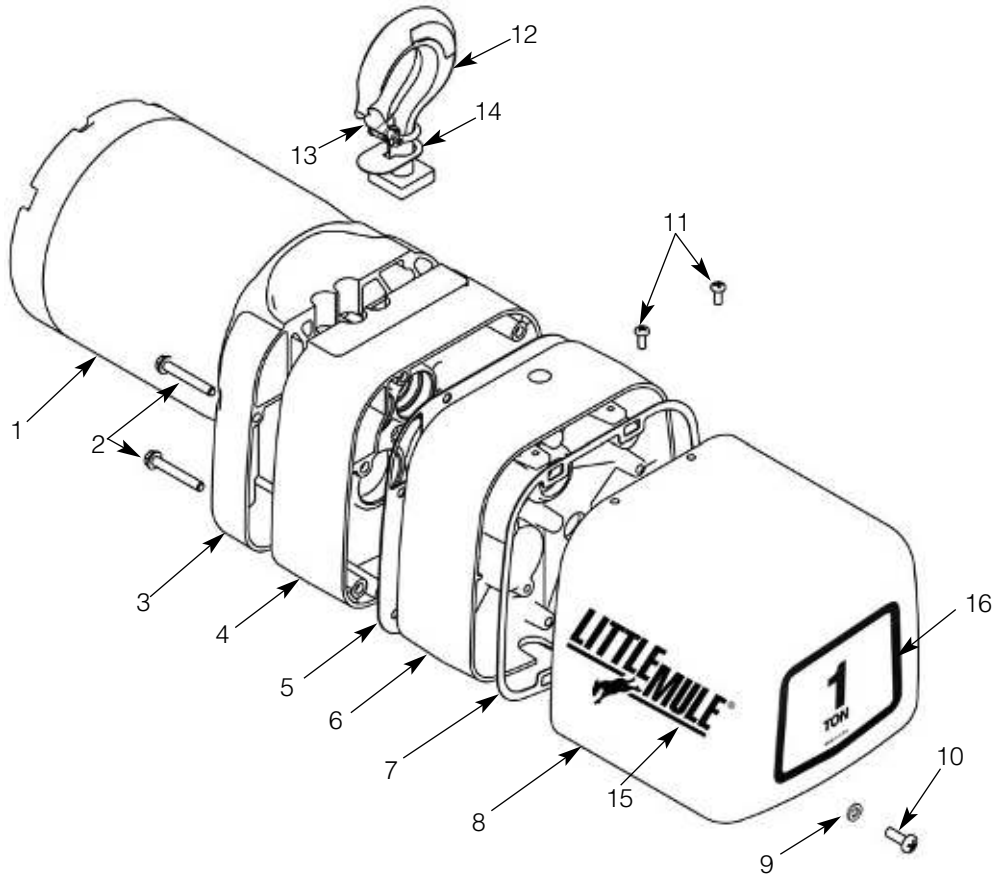

Parts List for Basic Hoist

Ref No.	Description	Part No.	Qty	Ref No.	Description	Part No.	Qty
1	Motor (See Figures 13 & 14)	—	1	12	Top Hook Assembly w/Latch Rigid (Standard)	3M205A02S	1
2	Sheave Housing Screw	H2978P	4		Swivel	3M205A01S	1
3	Sheave Housing 1/4 & 1/2 Ton	JL33	1	13	Latch Kit Assembly	4X1305	1
	1 & 2 Ton	JL39	1	14	Hook Hole Cover	JF277 1	1
4	Gear Housing 1/4 & 1/2 Ton	JL35	1	15	Little Mule Decal	LMS677	2
	1 & 2 Ton	JL44	1	16	Capacity Decal		
5	Gear Case Gasket	JL560	1		1/4 Ton	YJL675-1	1
6	Gearbox Cover	JL34	1		1/2 Ton	YJL675-2	1
7	Electrical Cover Gasket	JL563	1		1 Ton	YJL675-3	1
8	Electrical Cover	JF36-6	1		2 Ton	YJL675-4	1
9	1/4" Spring Lockwasher	H4062P	1	*	Nylon Cover (Optional)		
10	1/4 - 20UNC X 3/4" Screw	H1106P	1		1/4 Ton	08771W	1
11	10 - 24UNC X 1/2" Screw	H2970	2		1/2 Ton	08772W	1
					1 Ton	08773W	1
					2 Ton	08774W	1

* Not Shown

Contact your nearest Little Mule Service Center for parts and service. For a complete list, see pages 30 and 31. Please have the hoist model number, serial number, and part number with description available for reference.

Figure 13 - Hoist Motor, 1-Phase

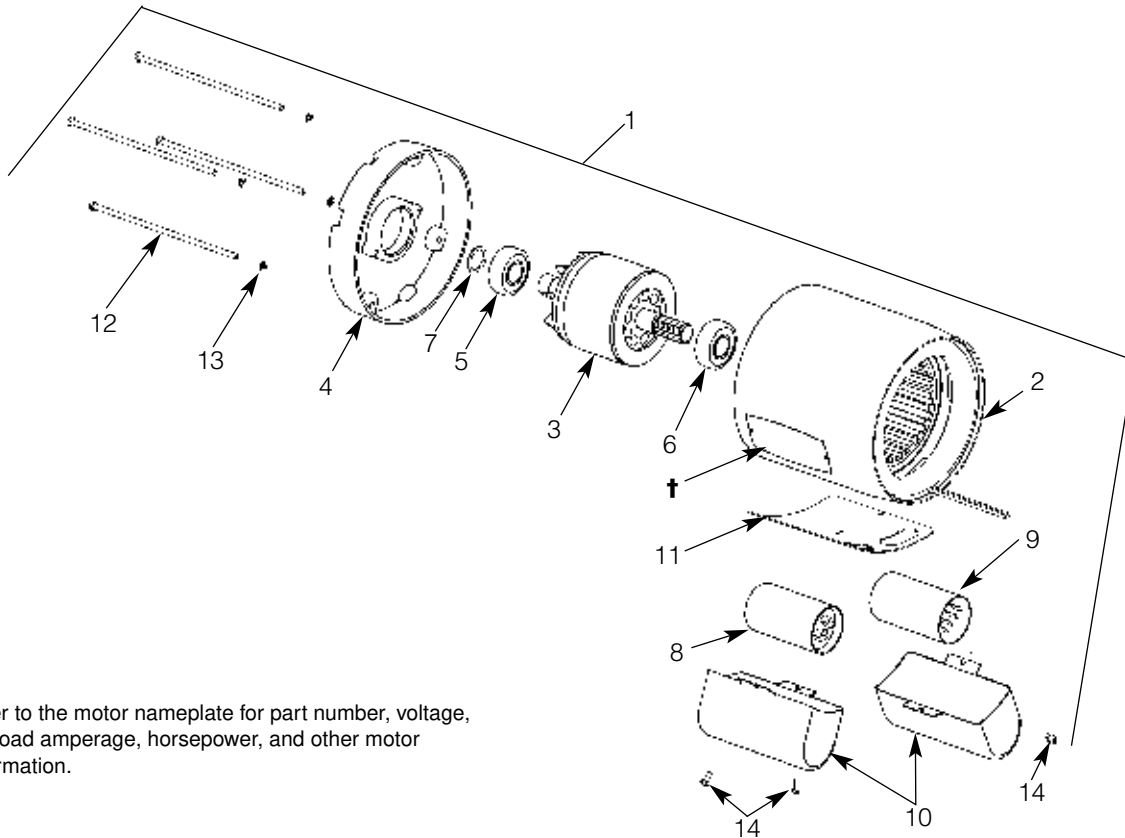

† Refer to the motor nameplate for part number, voltage, full load amperage, horsepower, and other motor information.

Parts List for Hoist Motor, 1-Phase

Ref. No.	Description	Part No.	Qty
1	Hoist Motor		
	1/4 hp, 115/230V-1Ph	861JL11	1
	1/2 hp, 115/230V-1Ph	861JL12	1
	1 hp, 115/230V-1Ph	861JL14	1
2	Stator Assembly	*	1
3	Rotor Assembly	*	1
4	End Shield	JL021209-20	1
5	Rear Bearing	500K3	1
6	Front Bearing	732012C	1
7	Shim Washer	JL4301-01	1
8	Capacitor		
	1/4 & 1/2 hp	JL810-7	1
	1 hp	JL810-4	1
9	SINPAC® Starting Switch	839J2	1
10	Capacitor/Start Switch Cover	JL3108-03	2
11	Gasket	JL564	1
12	Thru Bolt		
	1/4 & 1/2 hp	JL003801-41	4
	1 hp	JL003801-19	4
13	#10 Spring Lockwasher	H4082P	4
14	8-32UNC X 5/16" Screw	H2751	3

* Not available as an individual part.



Contact your nearest Little Mule Service Center for parts and service. For a complete list, see pages 30 and 31. Please have the hoist model number, serial number, and part number with description available for reference.

Figure 14 - Hoist Motor, 3-Phase

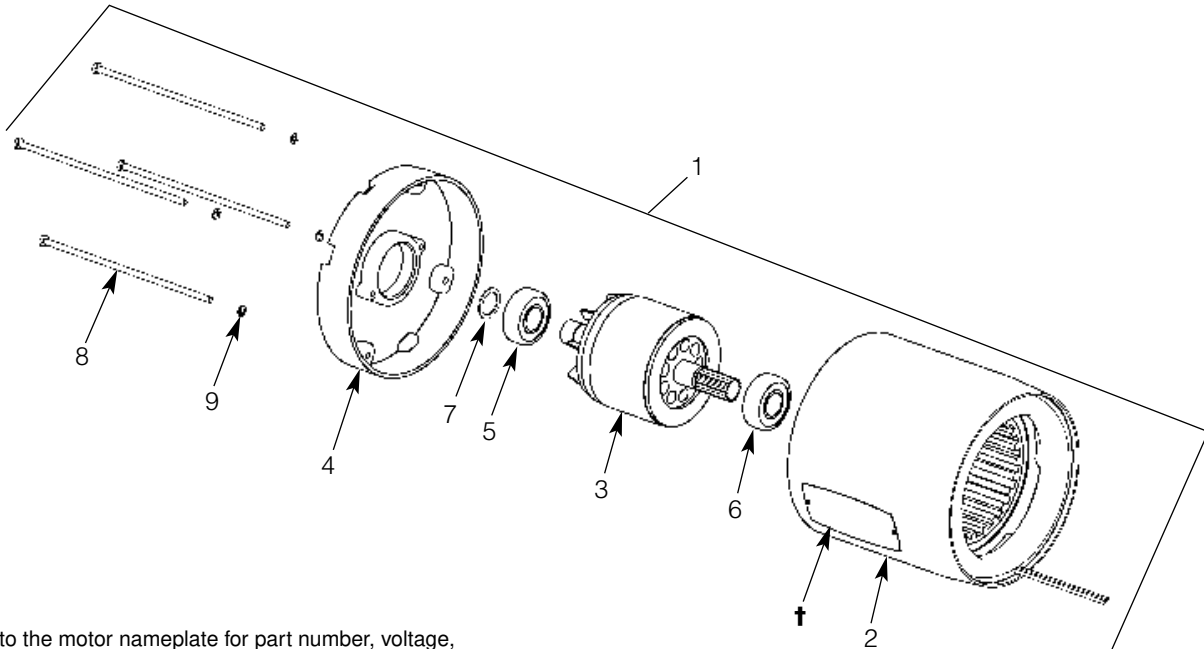

† Refer to the motor nameplate for part number, voltage, full load amperage, horsepower, and other motor information.

Parts List for Hoist Motor, 3-Phase

Ref. No.	Description	Part No.	Qty
1	Hoist Motor 1/4 hp, 230/460V-3Ph-60Hz 1/2 hp, 230/460V-3Ph-60Hz 1 hp, 230/460V-3Ph-60Hz	863JL1 863JL2 863JL4	1 1 1
2	Stator Assembly	*	1
3	Rotor Assembly	*	1
4	End Shield	JL021209-20	1
5	Rear Bearing	500K3	1
6	Front Bearing	732012C	1
7	Shim Washer	JL4301-01	1
8	Thru Bolt 1/4 & 1/2 hp 1 hp	JL003801-62 JL003801-35	4 4
9	#10 Spring Lockwasher	H4082P	4

* Not available as an individual part.

Contact your nearest Little Mule Service Center for parts and service. For a complete list, see pages 30 and 31. Please have the hoist model number, serial number, and part number with description available for reference.

Figure 15 - Brake & Solenoid Parts

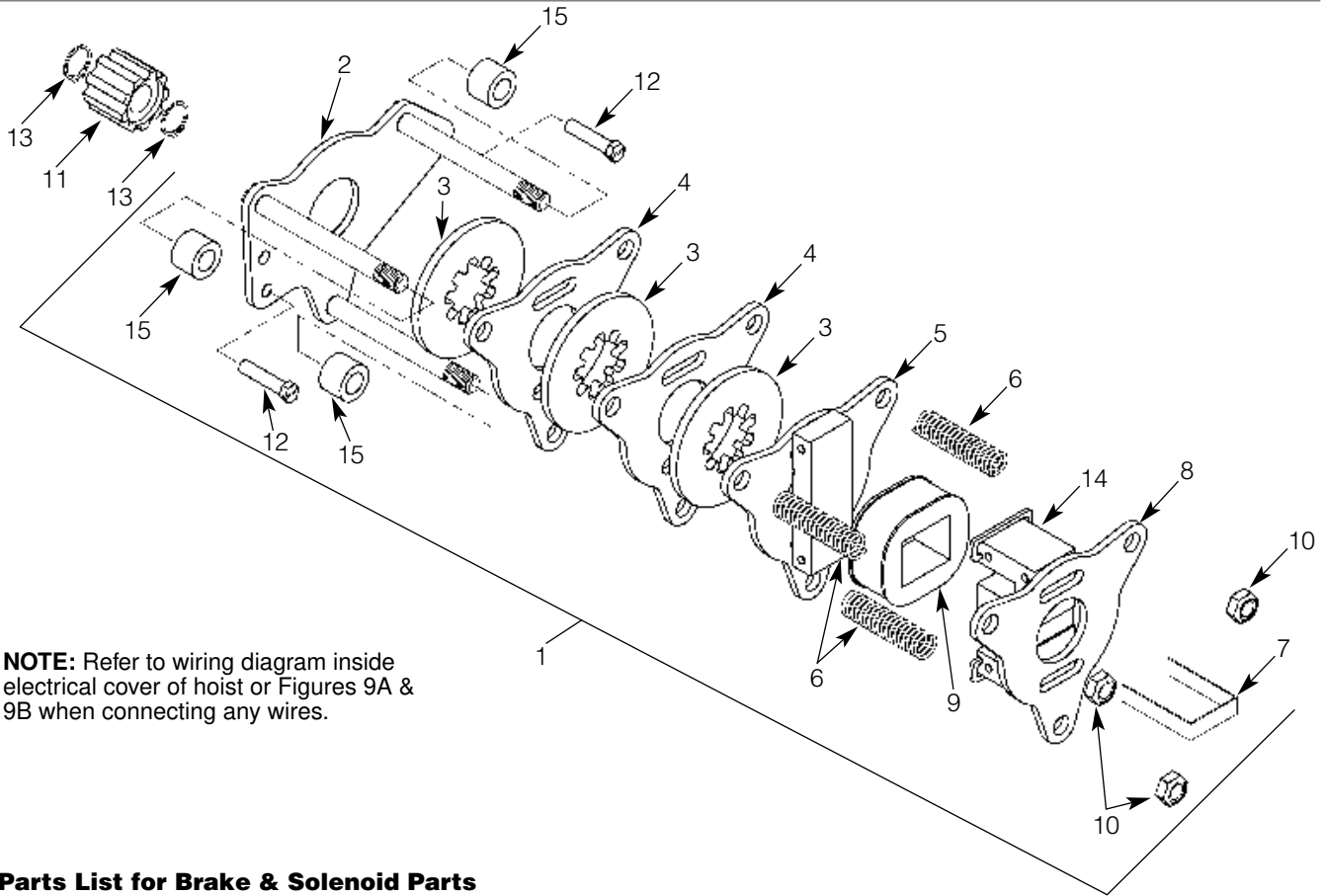

NOTE: Refer to wiring diagram inside electrical cover of hoist or Figures 9A & 9B when connecting any wires.

Parts List for Brake & Solenoid Parts

Ref No.	Description	Part No.	Qty	Ref No.	Description	Part No.	Qty
1	Disc Brake Assembly			6	Spring	344J6	3
	1/4 hp, 115/230V	854JL1	1	7	Retainer	JF710	1
	1/2 hp, 115/230V	854JL2	1	8	Plate & Frame Assembly	JF857	1
	1 hp, 115/230V	854JL3	1	9	Brake Coil		
	1/4 hp, 230/460V	854JL4	1		115/230V	853JL1	1
	1/2 hp, 230/460V	854JL5	1		230/460V	853JL2	1
2	Plate & Stud Assembly	JF859A	1	10	Locknut	H3978	3
				11	Adapter	JL142	1
3	Brake Disc			12	Screw	H2976P	2
				13	Retaining Ring	H5501	2
				14	Shading Coil	860J1	2
4	Brake Plate for 1/4 hp	JF291	1		Shading Coil Adhesive	H7812	1
				15	Spacer for 1/4 hp	JL141	3
5	Plate & Armature Assembly	JF858	1		Spacer for 1/2 hp	141J2	3



Contact your nearest Little Mule Service Center for parts and service. For a complete list, see pages 30 and 31. Please have the hoist model number, serial number, and part number with description available for reference.

Figure 16 - Electrical Parts

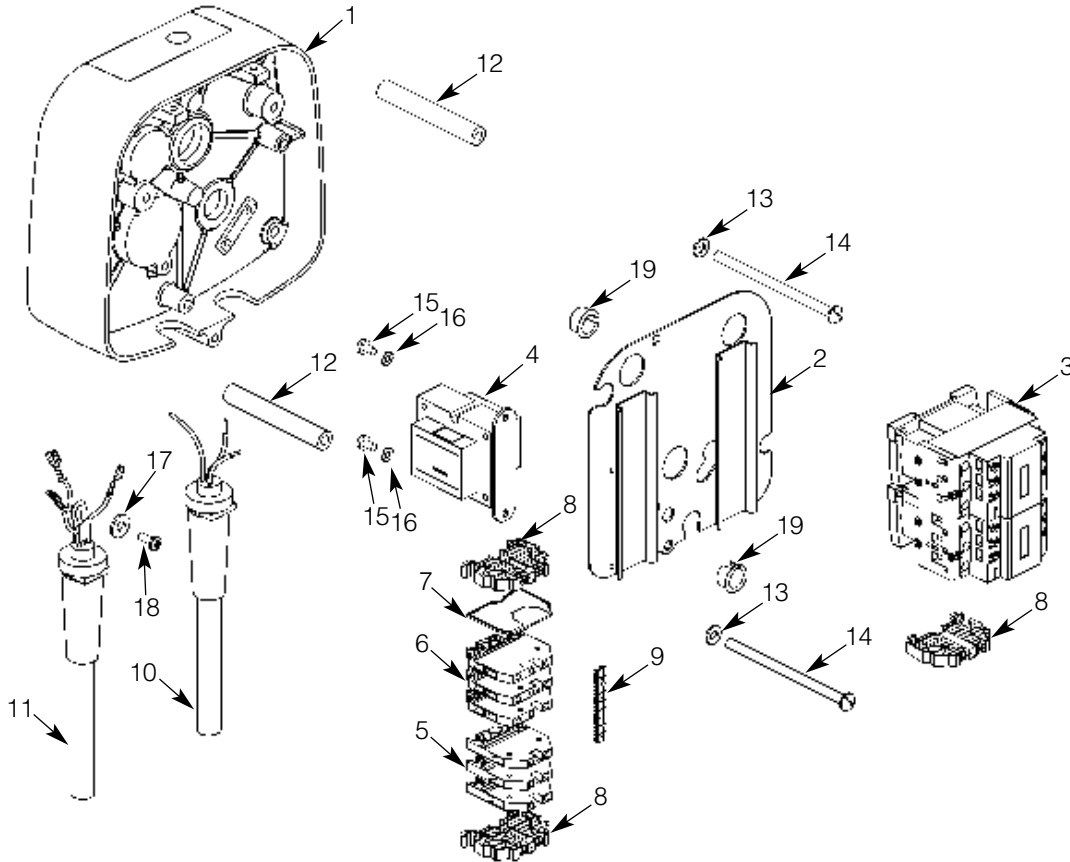

Parts List for Electrical Parts

Ref No.	Description	Part No.	Qty	Ref No.	Description	Part No.	Qty
1	Gear Box Cover	JL34	1	8	End Clamp	909J13	3
2	Panel Plate	257JL200	1	9	Marking Strip	909J11	1
3	Reversing Contactor			10	15 ft Power Cord Assembly		
	1 hp, 115/230V	24791	1		115/230V, 1/2 & 1/4 hp	951JL1	1
	1 hp, 230/460V	25943	1		(3 cond.)		
	1/2 hp & 1/4 hp	28860	1		115/230V, 1 hp (3 cond.)	952JL1	1
4	Transformer				230/460V (4 cond.)	953JL1	1
	Pri.: 115/230V, Sec.: 24V	821J412	1	11	PB & Cable Assembly	-	1
	Pri.: 230/460V, Sec.: 24V	821J432	1		(See Figure 17)		
5	Terminal Block			12	Panel Standoff Spacer	110JL1	2
	115/230V	909J10	1	13	1/4" Internal-tooth Lockwasher	H4134	2
	230/460V	909J10	8	14	1/4-20UNC X 4" Screw	H1110P	2
6	Terminal Block, 115/230V	909J14	4	15	8-32UNC X 5/16" Screw	H2751	2
7	End Plate			16	#8 External-tooth Lockwasher	H4158	2
	115/230V	909J15	1	17	1/4" Flatwasher	H4002P	1
	230/460V	909J12	1	18	10-24UNC X 1/2" Screw	H2970	1
				19	Grommet	H9086	2

Contact your nearest Little Mule Service Center for parts and service. For a complete list, see pages 30 and 31. Please have the hoist model number, serial number, and part number with description available for reference.

Figure 17 - Pushbutton Station

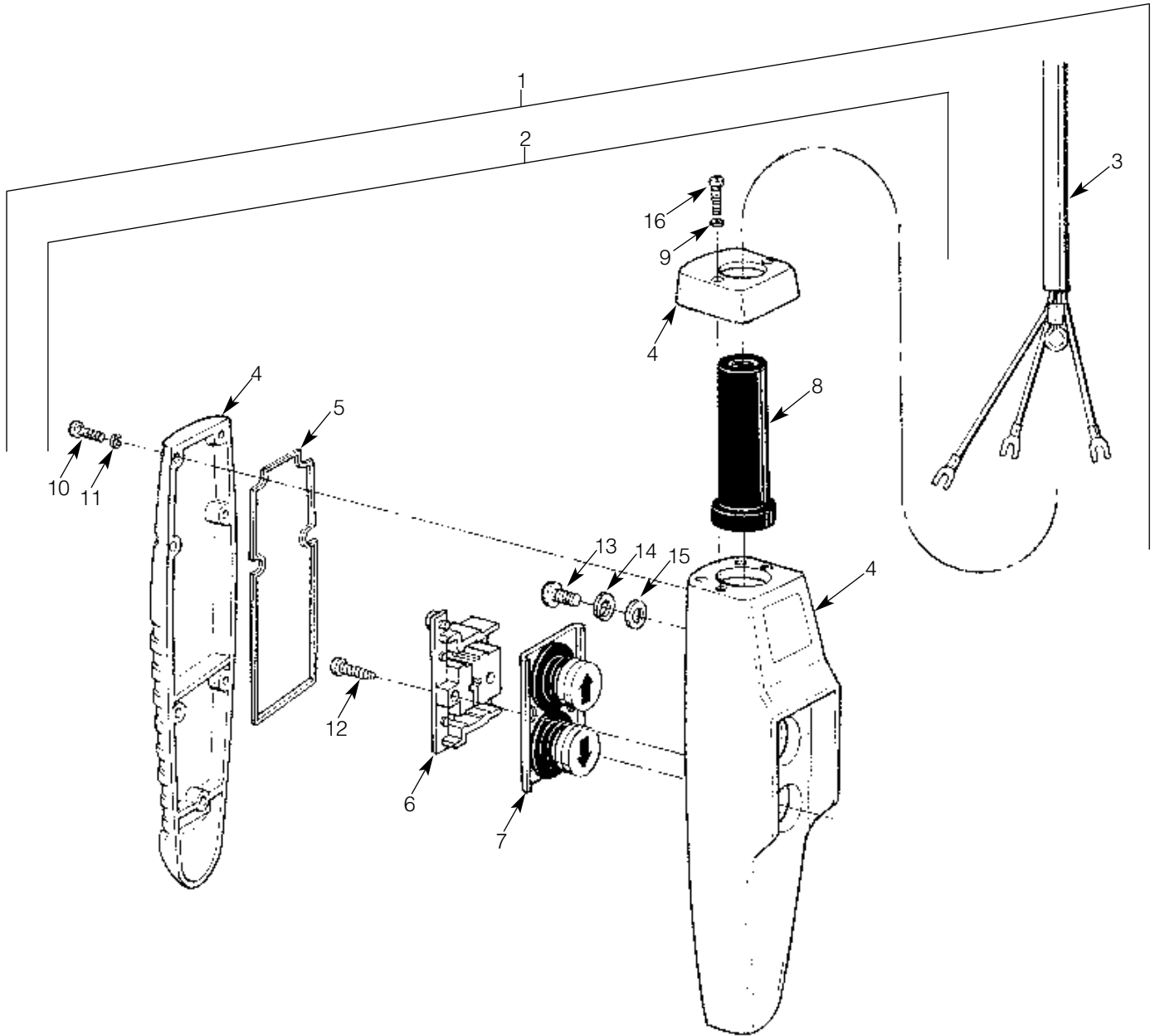

Contact your nearest Little Mule Service Center for parts and service. For a complete list, see pages 30 and 31. Please have the hoist model number, serial number, and part number with description available for reference.

Parts List for Pushbutton Station

Ref. No.	Description	Part No.	Qty
1	Pushbutton Station & Control Cable Assembly		
	6 ft Cable Length	PB299-6C	1
	11 ft Cable Length	PB299-11C	1
	16 ft Cable Length	PB299-16C	1
	Special Drop	PB299- †C	1
2	Pushbutton Station Assembly	36900	1
3	Control Cable Assembly		
	6 ft Cable Length	PBC299-6	1
	11 ft Cable Length	PBC299-11	1
	16 ft Cable Length	PBC299-16	1
	Special Drop	PBC299- †	1
4	Enclosure	36998	1
5	Gasket	36986	1
6	Contact Assembly	36987	1
	(Includes Items 6 & 7 when ordered)		
7	Button Assembly	36988	1
8	Grommet	36989	1
*	Hardware Kit	36939	1
	(Includes Items 9-16)		
△	Warning Tag	687K3W	1

(†) Equal to cable length.

(△) Not shown.

Contact your nearest Little Mule Service Center for parts and service. For a complete list, see pages 30 and 31. Please have the hoist model number, serial number, and part number with description available for reference.

Figure 18 - Standard Limit Switch Parts

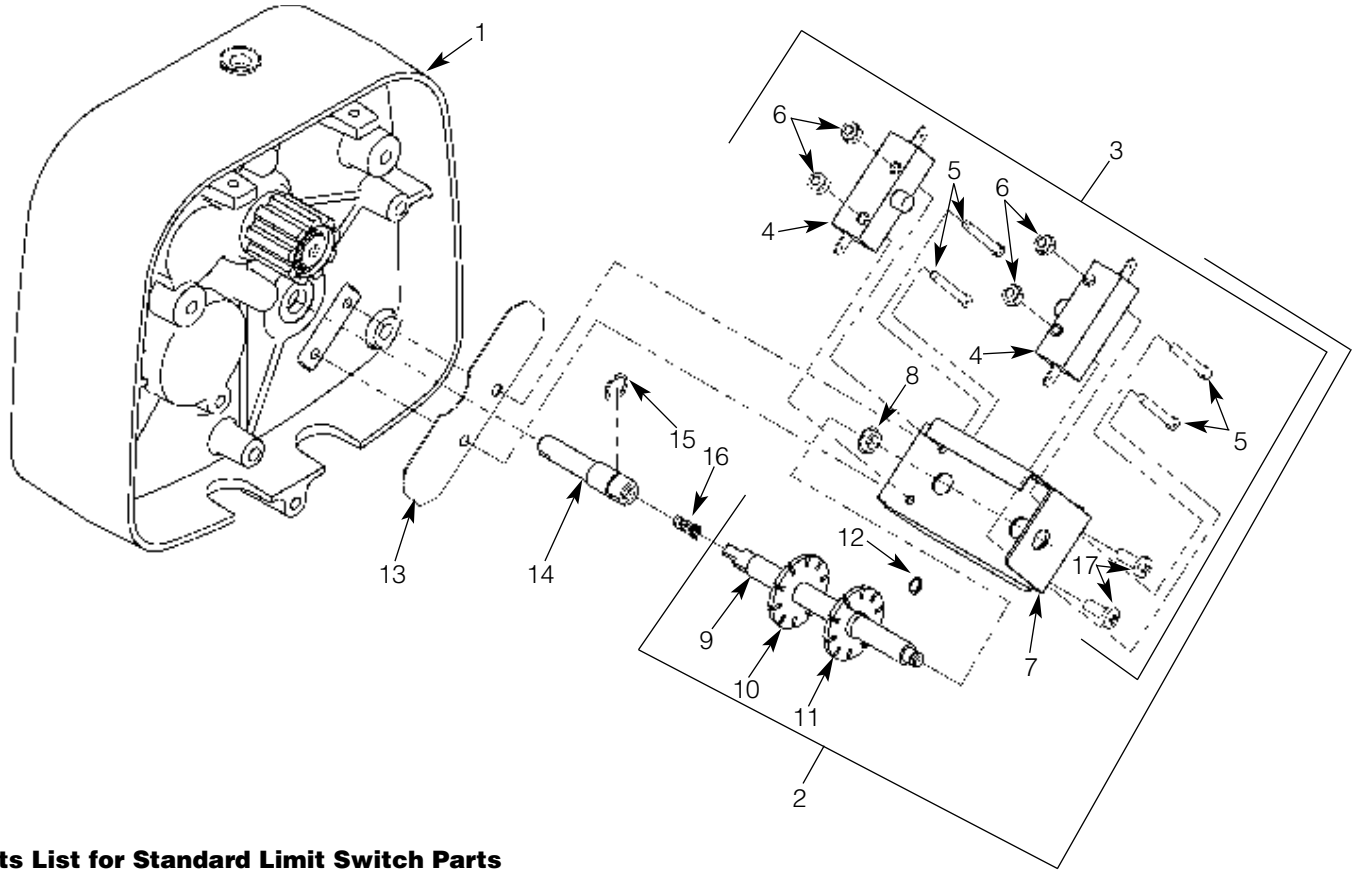

Parts List for Standard Limit Switch Parts

Ref No.	Description	Part No.	Qty	Ref No.	Description	Part No.	Qty
1	Gear Box Cover	JL34	1	8	Bushing	JF531-4	1
2	Limit Switch Assembly (Includes items 4-12)	918JG4	1	9	Limit Switch Shaft	JF117-3S	1
3	Limit Switch Bracket Assembly (Includes items 4-8)	918JG3	1	10	Limit Switch Nut (silver)	SK6000-63Z	1
4	Switch	815J1	2	11	Limit Switch Nut (gold)	SK6000-63W	1
5	6-32UNC X 1" Screw	H1402P	4	12	Retaining Ring	H5520	1
6	6-32UNC Elastic Locknut	H3944	4	13	Insulator	JF754	1
7	Limit Switch Bracket (Includes item 8)	JF900-3	1	14	Limit Switch Stub Shaft	JL140	1
				15	E-Ring	H5563	1
				16	Spring	JF343-3	1
				17	10-24UNC X 1/2" Screw	H2970	2



Contact your nearest Little Mule Service Center for parts and service. For a complete list, see pages 30 and 31. Please have the hoist model number, serial number, and part number with description available for reference.

Figure 19 - Long Lift Limit Switch Parts

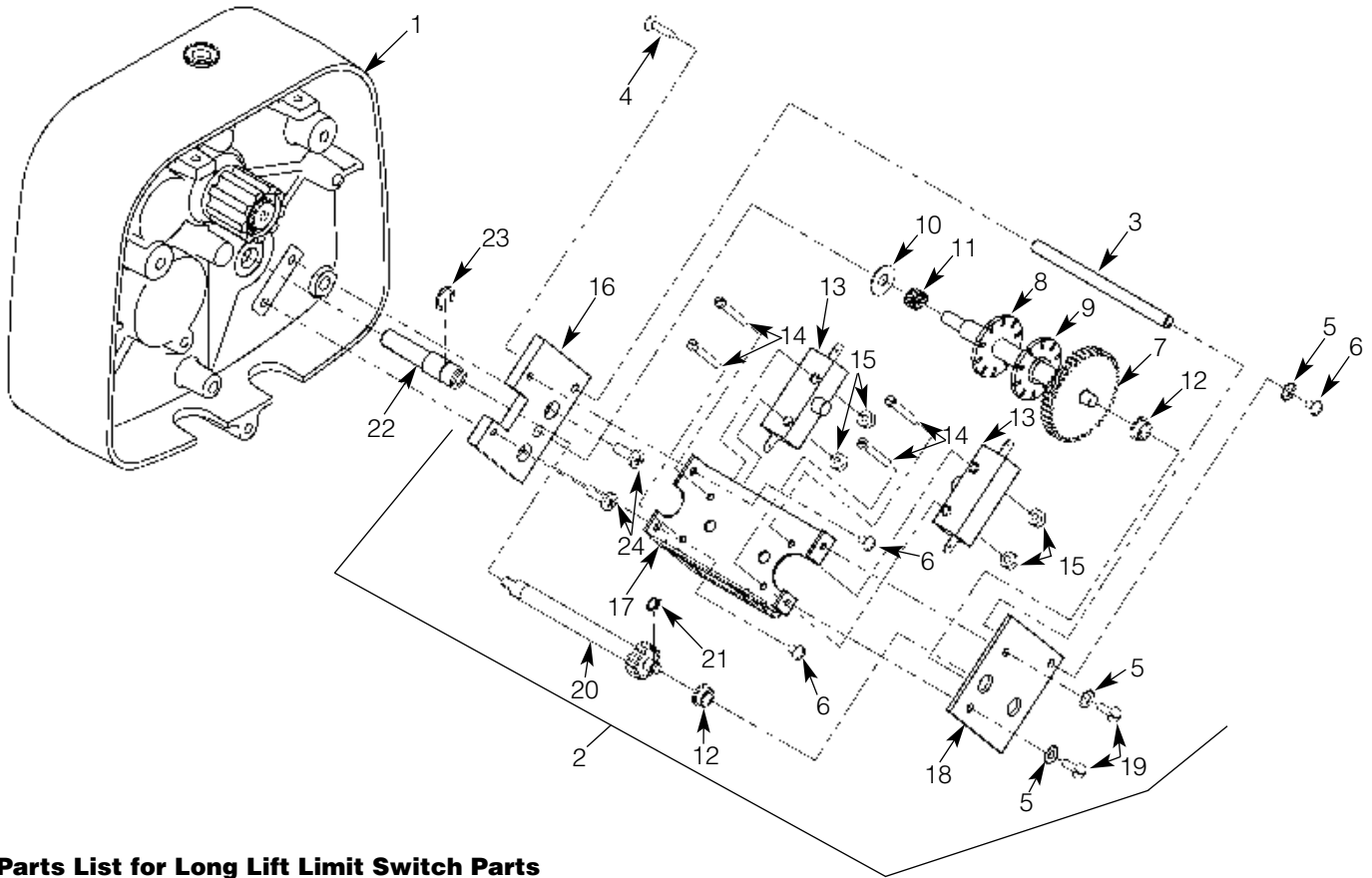

Parts List for Long Lift Limit Switch Parts

Ref No.	Description	Part No.	Qty	Ref No.	Description	Part No.	Qty
1	Gear Box Cover	JL34	1	13	Switch	815J1	2
2	Limit Switch Assembly (Includes items 3 - 21)	944JG6	1	14	6-32UNC X 1" Screw	H1402P	4
3	Post	110J14	1	15	6-32UNC Elastic Locknut	H3944	4
4	8-32UNC X 1/2" Screw	H1210	1	16	Mounting Plate	129J1	1
5	#8 External-tooth Lockwasher	H4158	3	17	Frame and Guide Assembly	258JG7	1
6	8-32UNC X 1/4" Screw	854823	3	18	End Plate	258J8	1
7	Limit Switch Shaft & Gear	117JG2	1	19	8-32UNC X 3/8" Screw	H2741P	2
8	Limit Switch Nut (gold)	SK6000-63W	1	20	Drive Pinion	427J1	1
9	Limit Switch Nut (silver)	SK6000-63Z	1	21	Retaining Ring	H5520	1
10	Thrust Washer	255K16	1	22	Limit Switch Stub Shaft	JL140	1
11	Spring	PB287	1	23	E-Ring	H5563	1
12	Bushing	JF531-4	2	24	10-24UNC X 3/8" Screw	H2981P	2

Contact your nearest Little Mule Service Center for parts and service. For a complete list, see pages 30 and 31. Please have the hoist model number, serial number, and part number with description available for reference.

Figure 20 - Gearbox

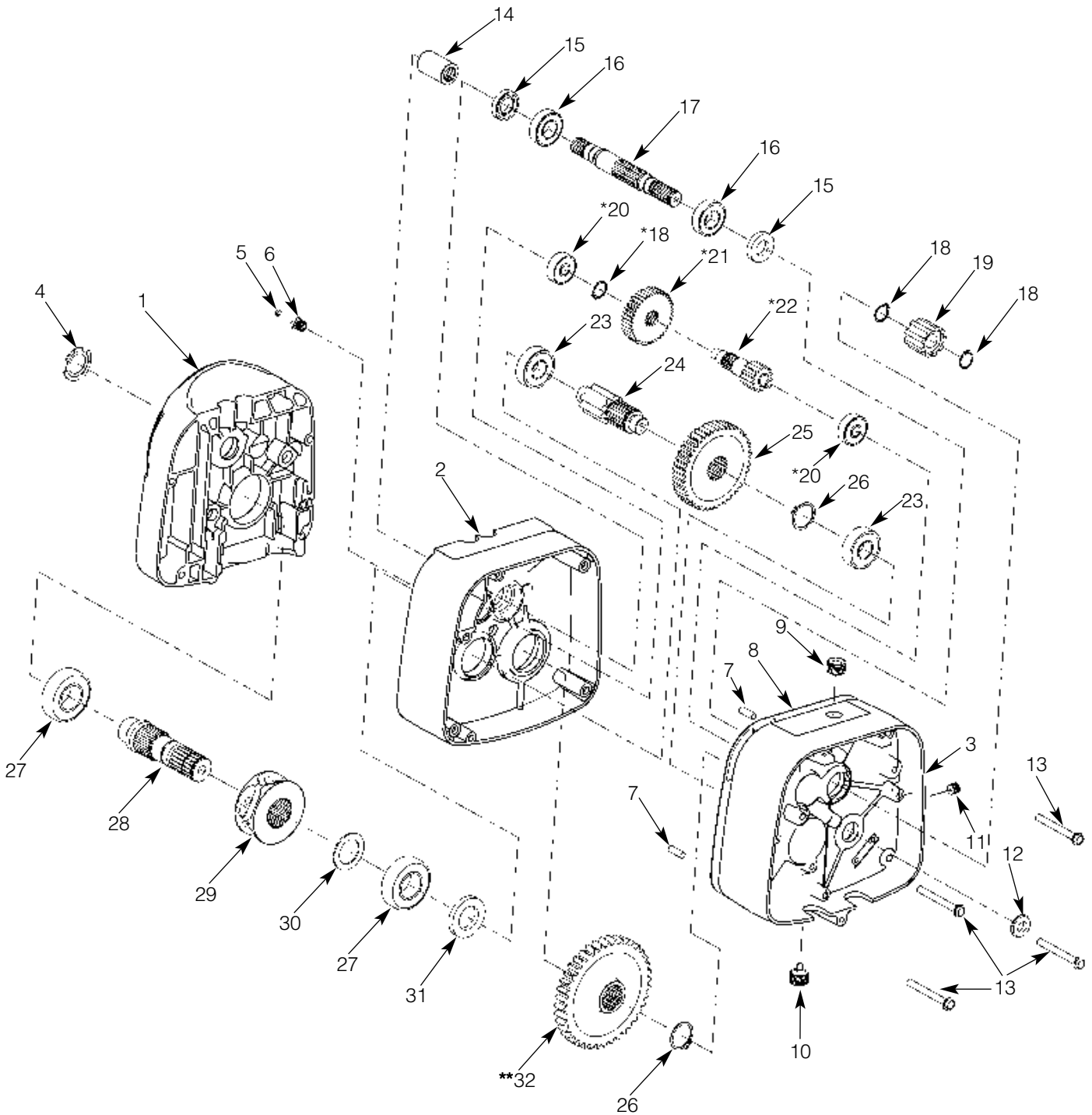

***NOTE:** This stage of gearing is not required on 32 FPM models.

****NOTE:** Orient output gear (32) with long boss towards gear housing (2) on 1/4 & 1/2 ton models and towards gear box cover (3) on 1 & 2 ton models.



Contact your nearest Little Mule Service Center for parts and service. For a complete list, see pages 30 and 31. Please have the hoist model number, serial number, and part number with description available for reference.

Parts List for Gearbox Parts

Ref. No.	Description	Part No.	Qty
1	Sheave Housing 1/4 & 1/2 Ton	JL33	1
	1 & 2 Ton	JL39	1
2	Gear Housing (Includes oil seals) 1/4 & 1/2 Ton	JL35	1
	1 & 2 Ton	JL44	1
3	Gear Box Cover (Includes oil seals)	JL34	1
4	Spring Washer	360J1	1
5	O-Ring	H5605	1
6	Pressure Relief Fitting	SK1912-21W	1
7	Dowel Pin	H5382	2
8	Gear Case Gasket	JL560	1
9	Oil Fill Plug	S25-4	1
10	Oil Drain Plug	H6268	1
11	Oil Level Check Plug	S25-13	1
12	Oil Seal	JL561	1
13	Screw	H2978P	4
14	Motor Coupling	JL107	1
15	Oil Seal	561K2	2
16	Bearing	500K33	2
17	Input Pinion 8 & 16 fpm	JL400B	1
	32 fpm	JL400-1	1
18	Retaining Ring	H5501	3
19	Brake Adapter	JL142	1
20	Bearing for 8 & 16 fpm	500K34	2
21	High Speed Gear for 8 & 16 fpm	JL426	1
22	Intermediate Pinion 1/4 & 1/2 ton, 16 fpm	JL402A	1
	1 & 2 ton	JL403A	1
23	Bearing	500K36	2
24	Output Pinion	JL401	1
25	Overload Clutch Assembly 1/4 Ton, 16 fpm	591JG25	1
	1/4 Ton, 32 fpm	591JG22	1
	1/2 Ton, 16 fpm	591JG16	1
	1/2 Ton, 32 fpm	591JG21	1
	1 & 2 Ton	591JG17	1
26	Retaining Ring	H5503	2
27	Bearing	JF504-2	2
28	Load Sheave Shaft Assembly (See Figure 21)	—	1
29	Load Sheave (See Figure 21)	—	1
30	Spacer (See Figure 21)	—	1
31	Oil Seal	561K20	1
32	Output Gear 1/4 & 1/2 Ton	JL420	1
	1 & 2 Ton	JL421	1
*	SAE 90 EP Gear Oil	H7642	1½ pt

* Not Shown

Contact your nearest Little Mule Service Center for parts and service. For a complete list, see pages 30 and 31. Please have the hoist model number, serial number, and part number with description available for reference.

Figure 21 - Chaining Parts

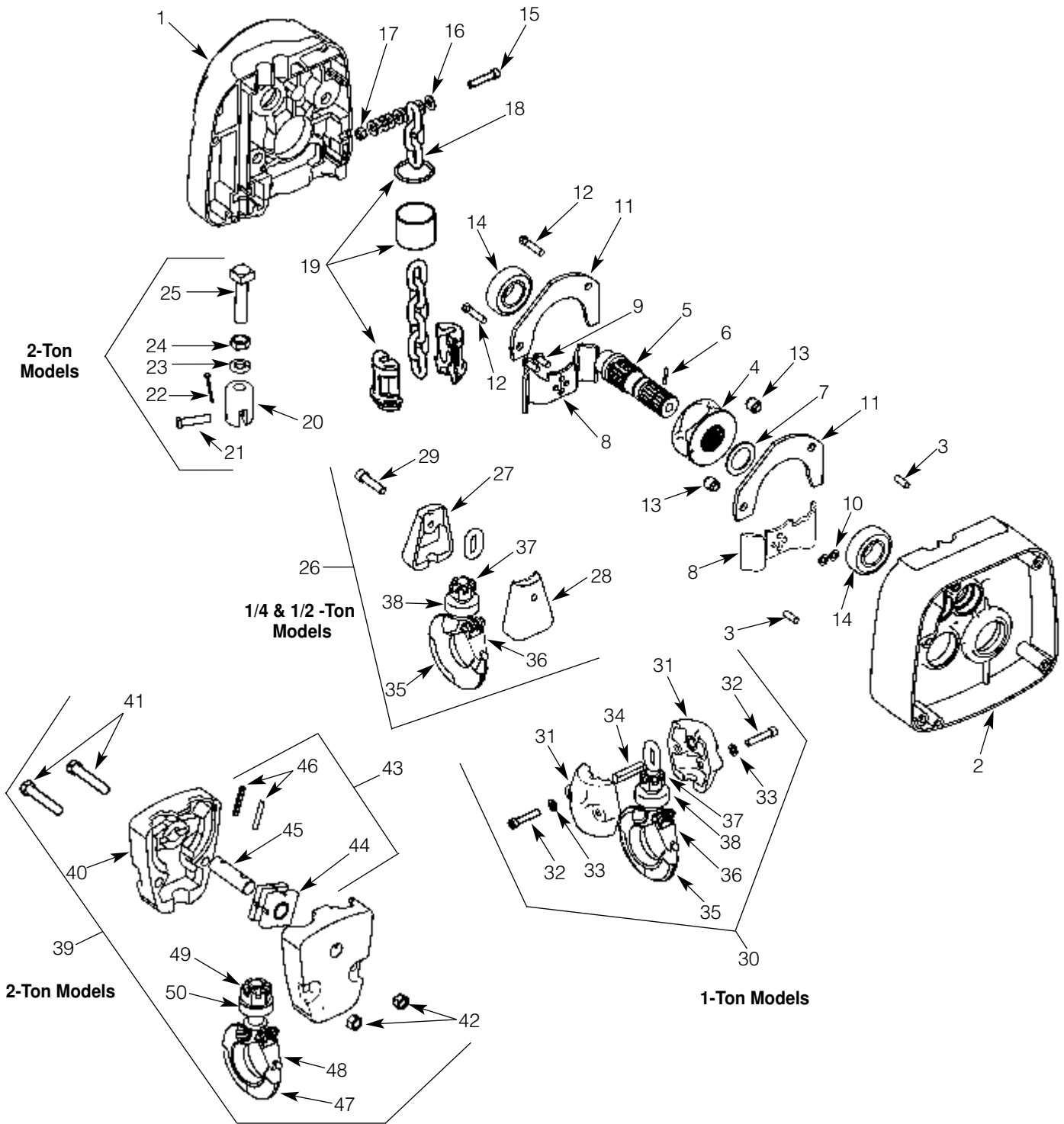

Contact your nearest Little Mule Service Center for parts and service. For a complete list, see pages 30 and 31. Please have the hoist model number, serial number, and part number with description available for reference.

Parts List for Chaining Parts

Ref No.	Description	Part No.	Qty	Ref No.	Description	Part No.	Qty
1	Sheave Housing			20	Chain Support	JF109	1
	1/4 & 1/2 Ton	JL33	1	21	Chain Support Pin	JL18	1
	1 & 2 Ton	JL39	1	22	Cotter Pin	H5025P	1
2	Gear Housing			23	Lockwasher	H4083P	1
	1/4 & 1/2 Ton	JL35	1	24	1/2-20UNF Hex Jam Nut	H3621P	1
	1 & 2 Ton	JL44	1	25	Chain Support Screw	JF703	1
3	Dowel Pin	H5382	2	26	Load Block Assembly	913JG4AS	1
4	Load Sheave				1/2 Ton & Under		
	1/4 & 1/2 Ton	JF16-4	1	27	Load Block Frame	JF20-2	1
	1 & 2 Ton	JF16-3	1	28	Load Block Frame (threaded)	JF20-3	1
5	Load Sheave Shaft	JL132	1	29	Load Block Screw	JF700	1
6	Roll Pin	H5240	1	30	Load Block Assembly, 1 Ton	913JG3AS	1
7	Spacer, 1 & 2 Ton	JF285	1	31	Load Block Frame	30J14	2
8	Chain Guide			32	1/4-20UNC X 1 1/4"	S49-77	2
	1/4 & 1/2 Ton	JF250-3	2		Socket Head Cap Screw		
	1 & 2 Ton	JF254-3	2	33	1/4" Internal-Tooth Lockwasher	H4134	2
9	Chain Guide Screw	H2976P	2	34	Load Block Pin	18J8	1
10	Washer, 1/2 Ton & Under	H4134	2	35	Bottom Hook Assembly	3JG20S	1
11	Chain Guide Plate				w/Latch, 1 Ton & Under		
	1/4 & 1/2 Ton	JF272	2	36	Latch Kit	4X1304	1
	1 & 2 Ton	JF273	2	37	Slotted Hex Nut	H3986P	1
12	Chain Guide Plate Screw	H2692P	2	38	Bearing	JF510	1
13	Chain Guide Plate Spacer	JF127	2	39	Load Block Assembly, 2 Ton	JF914-6	1
14	Bearing	JF504-2	2	40	Load Block Frame	JF30-1	2
15	Dead End Screw	S49-77	1	41	Load Block Screw	H2403P	2
16	1/4" Flatwasher	H4002P	8	42	3/8-24 UNF Hex Locknut	H3964P	2
17	Dead End Nut	H3845P	1	43	Sheave Shaft Assembly	JF917-1	1
18	Load Chain			44	Sheave & Bearing Assembly	JF916	1
	1/4 & 1/2 Ton	JL19B	*	45	Sheave Shaft	JF122-1	1
	1 & 2 Ton	JL19-1	*	46	Roll Pin	H5234	2
19	Chain Stop Kit			47	Bottom Hook Assembly	3KG1W	1
	1/4 & 1/2 Ton	75JG7K	1		with Latch, 2 Ton		
	1 & 2 Ton	75JG6K	1	48	Latch Kit	4X1305	1
	(Kit includes both halves, sleeve, and retaining ring)			49	Slotted Hex Nut	H3991P	1
				50	Bearing	JF511	1

* Replacement chain is sold by the foot. For single-chained models, add 2 ft to the lift for the total amount of feet. For double-chained models, double the lift and add 3 ft.



LIFETIME WARRANTY

Every Little Mule® hoist is thoroughly inspected and performance tested prior to shipment from the factory. If any properly installed, maintained and operated hoist as outlined in the applicable accompanying Little Mule® hoist manual develops a performance problem due to defective materials or workmanship as verified by Little Mule®, repair or replacement of the hoist will be made to the original purchaser without charge and the hoist will be returned, transportation prepaid. This warranty does not apply where deterioration is caused by normal wear, abuse, improper or inadequate power supply, improper or inadequate maintenance, eccentric or side loading,

overloading, chemical or abrasive actions, excessive heat, unauthorized modifications or repairs, or use of non-Little Mule® repair parts. **EXCEPT AS STATED HEREIN, LITTLE MULE® MAKES NO OTHER WARRANTIES, EXPRESS OR IMPLIED, INCLUDING WARRANTIES OF MERCHANTABILITY AND FITNESS FOR A PARTICULAR PURPOSE.**

WARNING

Alterations or modifications of equipment and use of non-factory repair parts can lead to dangerous operation and injury.

TO AVOID INJURY:

- Do not alter or modify equipment
- Do not use equipment to lift, support or otherwise transport people
- Do not suspend unattended loads over people



Country Club Road • P.O. Box 779
Wadesboro, NC 28170 U.S.A
Phone 800-477-5003 • 704-694-2156
Fax 800-374-6853