

**737**

**PRELIMINARY  
MANUAL**

-----  
 SERVICE MANUAL PARTS LIST      THU, AUG 15, 1996, 11:29 AM  
 -----

YALE ORDER NO. PRELIMINARY  
 QTY:     1     MODEL     : FEW35-52RT8D6  
 SERIAL NUMBER : XXXXXXXXX

CUSTOMER: XXXXXXXXXXXXXXXXXXXX  
 P.O. NO.: XXXXXXXX

ITEM DESCRIPTION	QTY.	PART NO.	SECT.
<b>Control Components</b>			2300
FUSE 01500-60-081X500D	3	056701000	
FUSE 05000-60-106X500D	3	646265800	
AUX CONTACT FOR DPA/DPR 1NO-1NC	1	648030420	
CONTACTOR D-3/0-12SQ	1	648034402	
RELAY 11B30C02----P	1	648318101	
RELAY 11A30-00CE02P	4	645785302	
FUSE 00160-25-041X150D	1	645839808	
XFMR 150VA462-12--MU	1	647896323	
AUX CONTACT FOR DPA/DPR 1NO-1NC	2	648030420	
CONTACTOR C-3/0-12SQ (8910 DPA13U02 F	3	648033402	
CONTACTOR COIL 120V (SQ D 9998 DA1U02)	1	648030402	
CONTACTOR D-3/0-12SQ	5	648034402	
CONTACTOR COIL 120V (SQ D 9998 DA2U02)	1	648030412	
CONTACT KIT 1 POLE (SQ D 9998 DRC6)	3	648030431	
CONTACTOR B-3X3-12SQ	1	648036402	
CONTACTOR COIL 120V (SQ D 9998 DA1U02)	2	648030402	
CONTACTOR D-3X3-12SQ	1	648038402	
CONTACTOR COIL 120V (SQ D 9998 DA2U02)	2	648030412	
CONTACT KIT 1 POLE (SQ D 9998 DRC6)	6	648030431	
ECB CONTROL 5042-1 230/460 VOLTS	1	648041301	
RELAY 11B30C03----P	10	648318105	
<b>Hoist Components</b>			
W/D TERMINOLOGY Rev. A	1	0000000WD	
GEARCASE ASM. COMPLETE	1	640793702	1340
G/C SEAL PACKAGE EEW/FEW H3/H4 (SERVICE	1	646018200	
H S GEAR FEW. 93T W/KEY 1.630X11.750X2	1	643748402	
INT PINION FEW. 14T W/KEY 8.06L 2.750D	1	643780400	
DR PINION EW-F 26.25L 20T@2.87D MS1.35	1	645598602	
BRG BALL SKF. 6220                             3937S	1	012148200	
BRG BALL SKF. 6207                             1378S	1	015125800	
BRG BALL SKF. 6215                             2953S	3	016493300	
OUTPUT SHAFT FEW.        22SPL 24SPL 13.62L	1	641954600	
S S GEAR FEW. 55T 22SPL 2.885X14.128X3	1	643743400	
S S PINION FEW. 14T 7.56L 4.128D	1	643744400	
INT GEAR FEW. 74T 14SPL 1.385X12.586X3	1	643745400	
BRG BALL SKF. 312                                2362S	1	644245800	
BRG BALL SKF. 6007-2RS                        1378S	1	644246800	
BRG BALL N.D. 1215 DR 215M (MAX) 2953S	1	644247800	
DRUM H4F-D09-56 0.663P 15.00PD 120.00LG	1	642260609	1120
ROPE RETAINER ASM	2	643934200	1120

ROPE ASM 56D662-S6X37-168 !!! REMARKS !!!	1	644265209	
Reeving Components			1630
SHEAVE R .50/.56-1.75FS15.81-5.90-W/RNG	4	642312602	
SHEAVE B .50/.56-1.50FS07.56-1.51	1	645776100	
PIN W/HOLES 1.87X 18.75 CL=16.25 RC 35-	1	648071100	
UPPER LIMIT SWITCH			1410
ROD L/S 10.00 LG STR. W/O HOLE 1/40 ALU	1	646777100	
LIMIT SWITCH 2 STAGE (SQ D C66B1-S22)	1	647342400	
FRAME H4F35D6LG09 (FOR TROLLEY SUSP)	1	644876609	1110
BOTTOM BLOCK ASSEMBLY	1	644908600	1640
SHEAVE BEARING	6	640162901	
HOOK BEARING	1	640171901	
SHEAVE R .62-----1.75FS15.81-5.90-W/RNG	6	642312600	
HOOK ASSEMBLY	1	644320200	1640
SAFETY LATCH KIT	1	644913800	
TNLS H4FE298H3EE268S2D2-2	1	644981122	1420
MICRO SWITCH W/ACTUATOR (JU-7 & U3-26-D	2	640205800	
SHAFT TNLS 3/8-24 L/HAND THD 6.59 LG W/	1	641289100	
WORM GEAR 2THD 1.25X .72X .315 (NYLON)	1	641293100	
GEAR (NYLON) 20T 1.380D X.311D (10-32TH	1	641294100	
COVER, TRAVELING NUT LIMIT SWITCH	1	642214300	
NUT, TNLS 1BT 3/8-24THD (NYLON) .31X 1.	2	644088300	
CAM RETAINER FOR TNLS	1	644910100	
RESISTOR ASM	1	645437300	
MOTOR 20-SF12W46236H655 1.875	1	647005600	
EDDY CURRENT BRAKE IBU-26 324/326	1	647384307	
DISC BRAKE 175-46216H-S82-S-M-12.50-LESS	1	648635443	1351
BRAKE DISC STEARNS 5-18-	2	649008303	1351
COIL KIT #9 230/460/H IM STEARNES 5-96	1	646462446	1351
DRUM BEARING	1	644152800	
YOKE, MTR "SF" F H4*1340*CL4.37 30T @4.3	1	649314400	1210
YOKE, G/C "F" EH3/FH4*1340*CL3.59 21T @3	1	649317400	1340
SPIDER ASM L16	2	649643100	1315
DR SHFT F-16-09 !!! USE WITH 1200 RPM MTR	1	649791102	1315
Pendant Components			2700
PENDANT SUPP. CABLE 1/8X7X7 (NYLON COVERE	49	003294000	
CORD 16/14 SO *CSA*	52	640013981	
PB HOUSING 6 BUTTON	1	645275306	
PB ELEMENT 1 SPD	1	645276301	
PB ELEMENT 5 SPD	1	645276305	
PB NAMEPLATE - HOIST UP/DOWN	1	645280301	
PB NAMEPLATE - TROLLEY FORWARD/REV.	1	645280303	
PB NAMEPLATE - OFF/ON	1	645280317	
PB ELEMENT MAINT/MOM	1	645595300	
DECAL, WARNING PHASE SEQUENCE	1	641373800	
ROPE CLAMP CROSBY 6426 1/8"	1	645591800	
SPLICE SLEEVE 1/8 SWAGE ALUM	1	645592800	
WARNING LABEL FOR P.B.	1	647206300	
WHEEL 10.0-P-BALL TD-W-C1. CST 3.12T SHLDR	8	066401700	
WHEEL 10.0-G-BALL TD-W-C1. CST 3.12T SHLDR	8	066443200	
AXLE GRP 10-W28R	16	643127200	
BRG TAPER CONE 2.25 BORE TYPE TS	2	065124700	
BRG TAPER CUP 3.87 O.D. TYPE TS #382	2	065124800	
PINION 10T TRK WHL RT 2.16DX1.76LG .751D	1	646290300	
GR BOX RT TROLLEY L/H 15:1 RATIO ASI & WF	2	646709303	
GR BOX RT TROLLEY R/H 15:1 RATIO ASI & WF	2	646709313	

MOTDR 01-CN18-4623683			4	647088300
SIDEPL EWB-10.0-P-P/M	1.25X12.50X27.00	5.3	4	648447187
SIDEPL EWB-10.0-G-P/M	1.25X12.50X27.00	5.3	4	648448197



## TABLE OF CONTENTS

<b>SAFE HOISTING PRACTICES</b> .....	<b>1</b>
Before Operating Hoist .....	1
Applying The Load .....	2
Moving The Load .....	2
Parking .....	3
Safety Laws for Passenger Elevators .....	3
Inspection, Preventive Maintenance and Testing .....	3
<b>YALE AND HMI DUTY SERVICE CLASSIFICATION</b> .....	<b>4</b>
<b>REPAIR PARTS ORDERING INFORMATION</b> .....	<b>6</b>
Hoist Serial Numbers .....	6
Return of Parts .....	6
Recommended Spare Parts List For One Year Operation .....	7
<b>INSTALLATION INSTRUCTIONS</b> .....	<b>8</b>
Adjustments of Limit Switches .....	9
Basic Suspensions .....	10
Trolley Adjustment .....	11
<b>PREVENTIVE MAINTENANCE SCHEDULE</b> .....	<b>12</b>
Daily Inspection .....	12
Monthly Inspection .....	13
Quarterly Inspection .....	14
Annual Inspection .....	14
Function Testing After Repair .....	15
Hook Dimensions (Except FEW) .....	16
Hook Dimensions (FEW) .....	16
Load Brake Disc Wear - Standard Load Brakes .....	16
Lubrication .....	17
Wire Rope Inspection .....	18
How To Measure Wire Rope .....	19
Procedure for Reeving Wire Rope on Drum .....	19
Double Reeved Units .....	19
Single Reeved Units .....	20
Reeving Types .....	20
Disassembly .....	23
Reassembly .....	26
Disassembly of Hoist EEW X & FEW .....	27
Assembly of Hoist .....	30
Troubleshooting (For all chassis and duty service except EEW X & FEW) .....	30
Unit Noisy .....	30
Oil Seepage .....	31
Load Drifts or Drops .....	31
Brake Coil Burned Out .....	32
Hoist Does Not Operate .....	32

**When Replacement Parts Are Needed, Order Only YALE® Factory Engineered Parts**

**PARTS AND INSTRUCTION MANUAL - EW SERIES**

**REVISED SEPTEMBER 1996**



## TABLE OF CONTENTS

---

Motor Overheats, Excessive Amperage Draw	33
Motor Noisy	33
Transformer Overheats or Burns Out	34
Reversing Contactor Coil Burned Out	34
Hoist Shocks Operator	34
Troubleshooting (For EEW X & FEW)	35
Unit Noisy	35
Oil Seepage	35
Load Drifts or Drops	35
Brake Coil Burned Out	36
Hoist Does Not Operate	36
Motor Overheats, Excessive Amperage Draw	37
Motor Is Erratic, Stop-Start, Etc.	38
Hoist Operates in Wrong Direction	38
Hoist Operates in One Direction	38
Motor Noisy	39
Transformer Overheats or Burns Out	39
Reversing Contactor Coil or Brake Solenoid Coil Burned Out	39
Hoist Shocks Operator	40
Wiring Device Terminology	Final Pages
Wiring Diagram (if required)	Final Pages
Powered Hoist Inspection Checklist	Final Pages
Special Instructions (if required)	Final Page
Warranty	Back Cover

**When Replacement Parts Are Needed, Order Only YALE® Factory Engineered Parts**

**PARTS AND INSTRUCTION MANUAL - EW SERIES  
REVISED SEPTEMBER 1996**



## TABLE OF CONTENTS

---

<b>SECTION</b>	<b>DESCRIPTION</b>
1110	User Information - Frame
1120	User Information - Drum
1210	User Information - Hoist Motor
1315	User Information - Drive Shaft ASM
1340	Gearing & Load Brake Information
1340	Gear Case Components
1340	Gear Case Components CEW X & CAW X
1351	Motor Brakes
1410	Upper Plugging Limit Switch
1420	Traveling Nut Limit Switch
1420	Geared Limit Switch Standard
1420	Geared Limit Switch Explosion Proof
1610	Wire Rope Assemblies
1630	Reeving Kits
1640	Bottom Blocks
2300	Control Components
2700	Push Buttons
3215	Trolley Idler Gear
3310	Trolley Motor
3320	Trolley ST Gearing
3323	Motorized Trolley Drive (RT)
3325	TR Drive Units
3326	TR Trolley Assembly Parts
3330	Trolley Handwheel Group
3351	Maintenance (Trolley Motor Brake)
3405	Wheel and Axle Group
3475	Trolley Guide Roller

**When Replacement Parts Are Needed, Order Only YALE® Factory Engineered Parts**

PARTS AND INSTRUCTION MANUAL - EW SERIES  
REVISED SEPTEMBER 1996



# TABLE OF CONTENTS

## COMMON MODEL NUMBER CODE FOR POWERED HOISTS

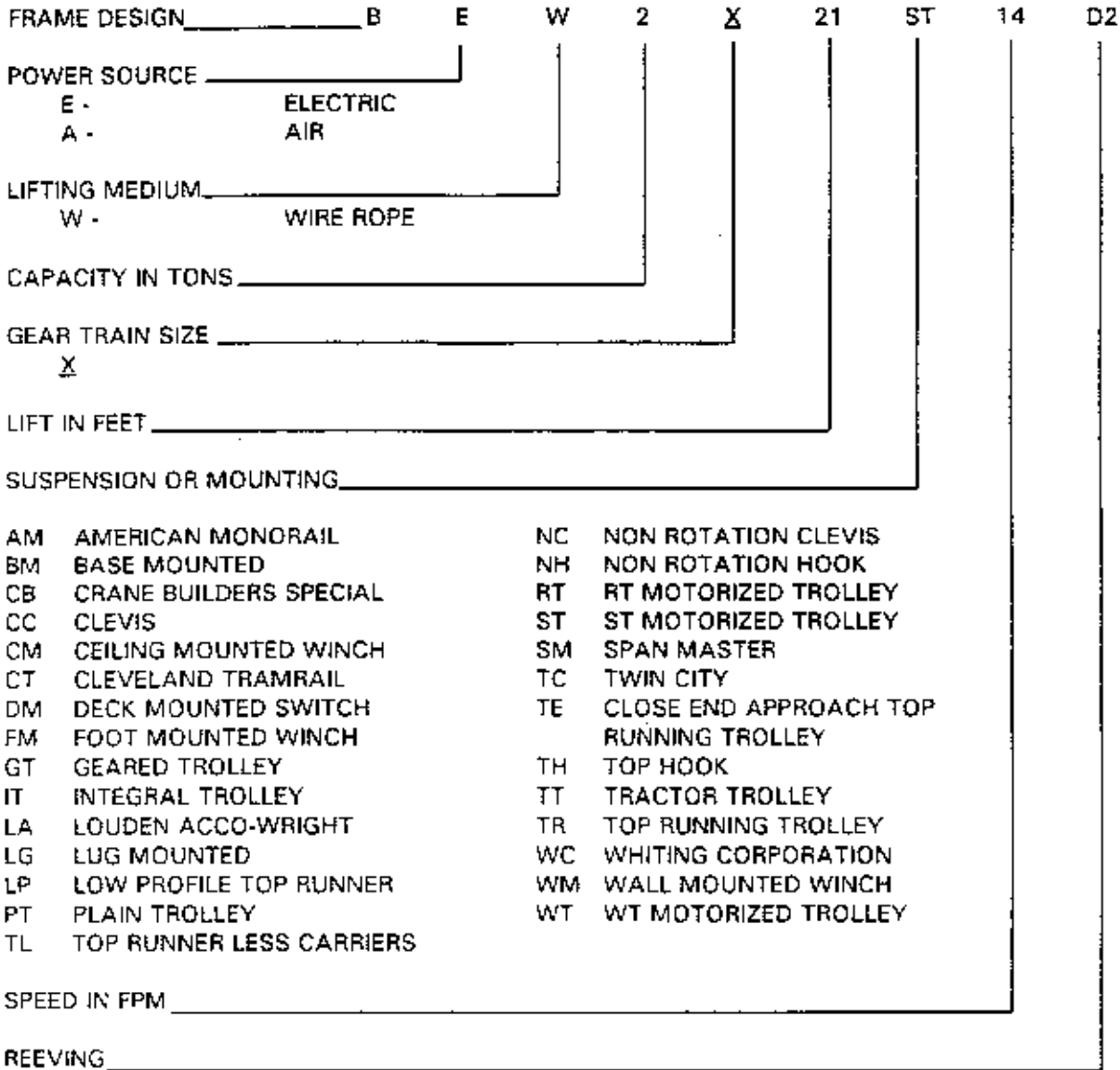

- AM AMERICAN MONORAIL
- BM BASE MOUNTED
- CB CRANE BUILDERS SPECIAL
- CC CLEVIS
- CM CEILING MOUNTED WINCH
- CT CLEVELAND TRAMRAIL
- DM DECK MOUNTED SWITCH
- FM FOOT MOUNTED WINCH
- GT GEARED TROLLEY
- IT INTEGRAL TROLLEY
- LA LOUDEN ACCO-WRIGHT
- LG LUG MOUNTED
- LP LOW PROFILE TOP RUNNER
- PT PLAIN TROLLEY
- TL TOP RUNNER LESS CARRIERS

- NC NON ROTATION CLEVIS
- NH NON ROTATION HOOK
- RT RT MOTORIZED TROLLEY
- ST ST MOTORIZED TROLLEY
- SM SPAN MASTER
- TC TWIN CITY
- TE CLOSE END APPROACH TOP RUNNING TROLLEY
- TH TOP HOOK
- TT TRACTOR TROLLEY
- TR TOP RUNNING TROLLEY
- WC WHITING CORPORATION
- WM WALL MOUNTED WINCH
- WT WT MOTORIZED TROLLEY

SPEED IN FPM \_\_\_\_\_

REEVING \_\_\_\_\_

- S STANDARD HEADROOM
- S1 ONE PART SINGLE REEVED
- S2 TWO PART SINGLE REEVED
- S3 THREE PART SINGLE REEVED
- S4 FOUR PART SINGLE REEVED
- D CLOSE HEADROOM
- D1 ONE PART DOUBLED REEVED
- D2 TWO PART DOUBLE REEVED
- D3 THREE PART DOUBLE REEVED

- X STD. HEADROOM, SPECIAL RIGHT ANGLE MTG.
- X1 ONE PART SINGLE REEVED
- X2 TWO PART SINGLE REEVED
- X3 THREE PART SINGLE REEVED
- X4 FOUR PART SINGLE REEVED
- D4 FOUR PART DOUBLE REEVED
- D5 FIVE PART DOUBLE REEVED
- D6 SIX PART DOUBLE REEVED

**When Replacement Parts Are Needed, Order Only YALE® Factory Engineered Parts**

PARTS AND INSTRUCTION MANUAL - EW SERIES  
REVISED SEPTEMBER 1996



# Yale® Hoists

**IMPORTANT**

**REVIEW THIS PAGE**

## PROCEDURE FOR LOCATING REPAIR PART INFORMATION

1. USE HOIST EXPLODED VIEW (S) TO IDENTIFY COMPONENTS OF INTEREST.

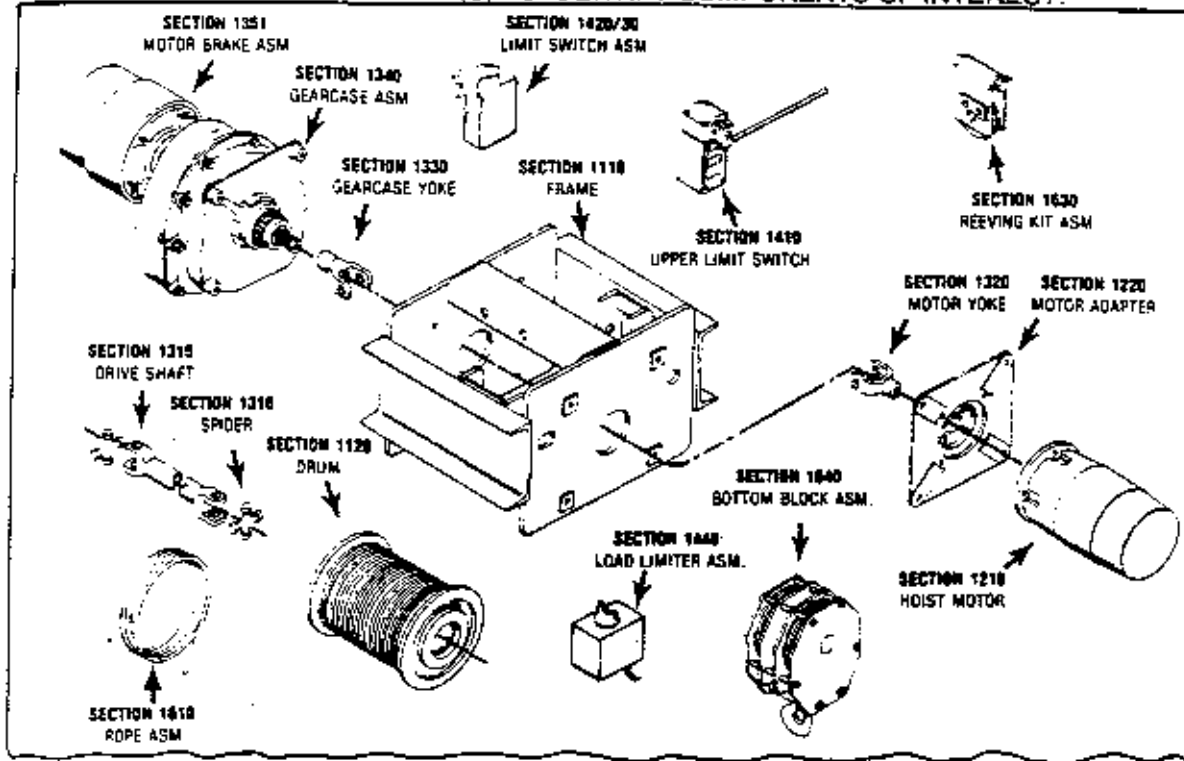

2. LOCATE THE CORRESPONDING 9 DIGIT COMPONENT/PART NUMBER FROM THE PARTS LIST.

PARTS LIST			
Description	Component Number	Section Number	Qty. Per Unit
Frame	647664100	1110	1000
Drum	645100100	1120	1000
Hoist Motor	642996800	1210	1000
Adapter, Motor	648484100	1220	1000

3. MORE INFORMATION AND A BREAKDOWN IS AVAILABLE IN THE BACK OF THE MANUAL FOR THOSE ASSEMBLIES DESIGNATED BY A SECTION NUMBER

SECTION 1351  
 MOTOR BRAKE  
 6436661-01-13  
**DIRECT ACTING BRAKE**

When Replacement Parts Are Needed, Order Only Yale® Factory Engineered Parts

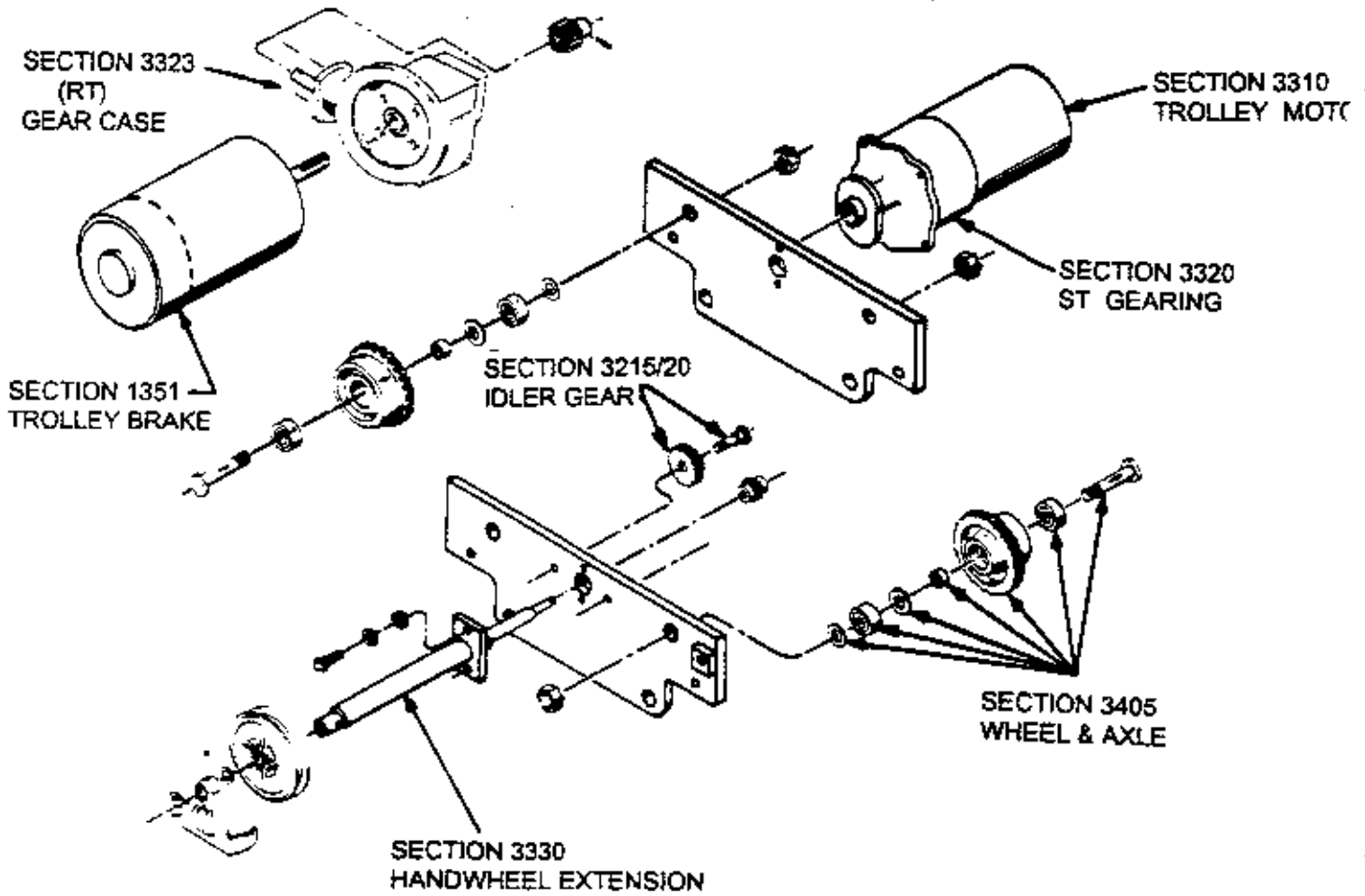

**ELECTRICAL CONTROLS**

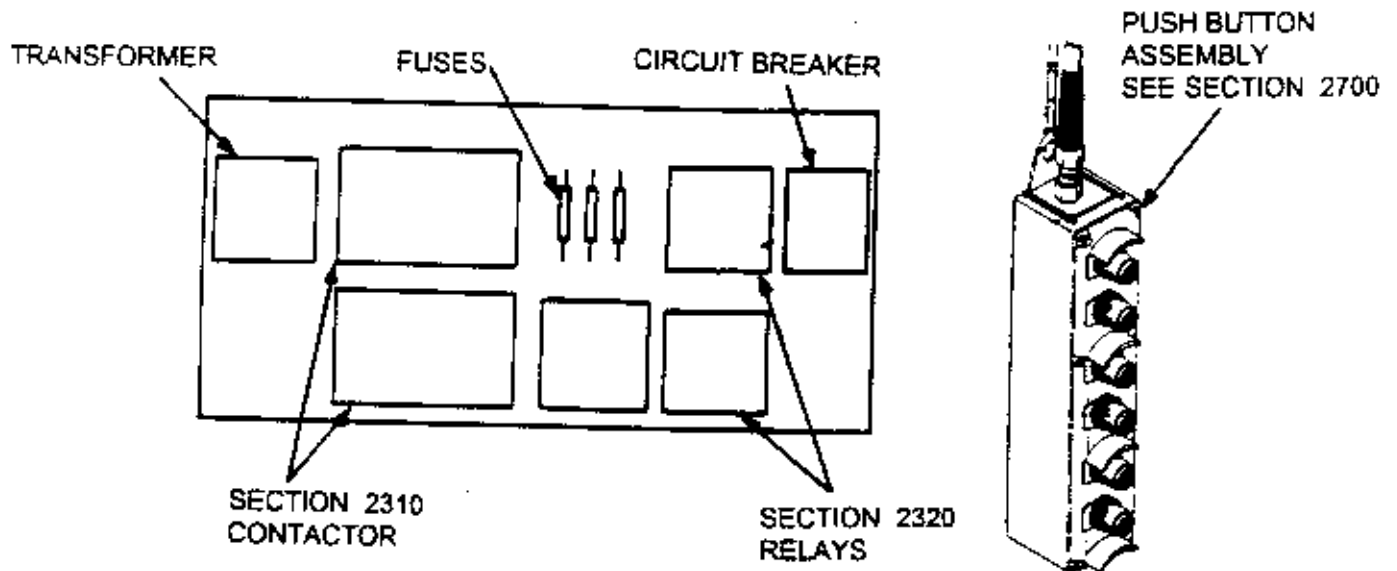

FORM 906-905-187

When Replacement Parts Are Needed, Order Only Yale ® Factory Engineered Parts



# **SAFE HOISTING PRACTICES**

---

For your own safety and that of your fellow workers, Material Handling Equipment must be used as recommended by the Manufacturer. Failure to heed the following recommendations could endanger your life. Use good common sense and judgement at all times. Safety is the responsibility of the operator of the equipment. You must be competent and attempt to foresee and avoid all hazardous conditions. To be safe as possible, the hoist must be given proper preventive maintenance and testing as described in the ANSI B30.16 Safety Code For Overhead Hoists and this manual.

## **Before Operating Hoist**

1. Do not operate hoist unless you are properly trained, physically fit, and authorized to do so. You must be familiar with all operating controls of the hoist, warnings and instructions on the hoist, the safe hoisting practices listed in this manual, ANSI B30.16 Safety Code For Overhead Hoists, and all pertinent Federal, State, and local regulations before beginning operation.
2. Do not allow unqualified personnel to operate the hoist.
3. Test all controls and limit switches and make sure hoist is well lubricated at beginning of each shift. Make sure needed lubrication, adjustments, or repairs are made by appointed personnel before operations are begun.
4. Be familiar with the equipment and its proper care. Do not operate hoist if adjustments or repairs are necessary, if any damage or undue wear is known or suspected, or if any warning, operating, or capacity instructions normally attached to hoist are damaged, obscured or missing. Report these items promptly to the proper person and also notify next operator when changing shifts.
5. Do not operate hoist if it is functioning improperly.
6. Do not operate hoist with an out-of-order sign attached until sign has been removed by a properly authorized person.
7. Do not adjust or repair hoist unless qualified for maintenance of hoist.
8. Be sure the power supply is disconnected before maintenance and repair procedure is performed.
9. Do not use the wire rope as a ground for welding.
10. Do not touch a welding electrode to the wire rope.

**When Replacement Parts Are Needed, Order Only YALE® Factory Engineered Parts**

**PARTS AND INSTRUCTION MANUAL - EW SERIES**

**REVISED SEPTEMBER 1996**

1



## **SAFE HOISTING PRACTICES (CONTINUED)**

---

### **Applying The Load**

11. Never wrap the wire rope around the load, or allow it to drag under load.
12. Always use slings or other approved devices to attach load.
13. Be sure the sling is properly seated in the saddle of the hook. Do not allow hook latch to support any part of load.
14. Do not apply a load to tip of hook, or in such a way as to cause bending or prying forces on the hook or hook support block.
15. Be sure wire ropes are not kinked or twisted or that multiple part ropes are not twisted about each other.
16. Do not operate hoist if wire rope is not seated properly in the grooves of the drum or sheaves.
17. Do not load hoist with less than two wraps of rope on the drum, unless a lower limit device is provided, in which case, no less than one wrap shall remain on the drum.
18. Center hoist unit over the load before lifting. Avoid side pull.
19. Never pick up a load beyond the rated capacity appearing on the hoist, except for properly authorized tests.
20. Do not use a load limiting device to measure the maximum load to be lifted. It is a safety device only.

### **Moving The Load**

21. Do not engage in any activity which will divert your attention while operating hoist.
22. Respond to signals from designated personnel only, except for stop signals.
23. Never lift a load with the hoist until you and all other personnel are clear of load.
24. Make sure load has proper clearance before moving.
25. Inch the hoist slowly into engagement with a load, but avoid excessive plugging, inching, and quick reversals of load.
26. Do not lift load more than a few inches until it is well balanced in the sling or lifting device.

**When Replacement Parts Are Needed, Order Only YALE® Factory Engineered Parts**

PARTS AND INSTRUCTION MANUAL - EW SERIES  
REVISED SEPTEMBER 1996



## **SAFE HOISTING PRACTICES (CONTINUED)**

---

27. Each time a load approaching rated capacity is handled, check load brake action by raising load just clear of supports and continuing only after you are sure brake is operating properly.
28. Do not transport load over personnel.
29. Never carry personnel on the hook or the load.
30. Avoid swinging of load or load hook when traveling the hoist.
31. On trolley mounted hoists, avoid sharp contact between trolleys, or between trolleys and rail stops.
32. Do not use limit devices as a normal means of stopping the hoist. These are emergency devices only.
33. Do not exceed the maximum duty cycle specified by the manufacturer.

### **Parking**

34. Do not leave load suspended in the air for extended or unattended periods.
35. Keep load block above head level when not in use.

### **Safety Laws for Passenger Elevators**

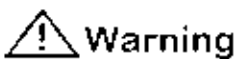

**Warning**

**DO NOT USE YALE HOISTS OR TROLLEYS FOR PASSENGER ELEVATOR APPLICATIONS**

The safety laws for passenger elevators specify construction details that are not incorporated in Yale Industrial Hoists. We recommend that passenger elevator operation equipment be used that meets all state and national safety codes. Yale Industrial Products, Inc. will not accept responsibility for applications of Yale Hoists on passenger elevators.

### **Inspection, Preventive Maintenance and Testing**

A preventive maintenance program should be initiated for this hoist immediately after it is entered into service. The preventive maintenance program should comply with recommendations in the applicable Yale Parts and Instruction Manual, and all pertinent Federal, State and Local regulations. Regular inspections, maintenance and testing required should be followed for the life of the hoist and written inspection records kept as specified. Sample inspection checklists are included in back of this manual. Extra inspection checklists can be obtained from your nearest authorized Yale Distributor.

**When Replacement Parts Are Needed, Order Only YALE® Factory Engineered Parts**

**PARTS AND INSTRUCTION MANUAL - EW SERIES  
REVISED SEPTEMBER 1996**



# YALE AND HMI DUTY SERVICE CLASSIFICATION

---

Yale Wire Rope Hoist models have been classified in terms of duty service. This duty classification of product assists in the choice of the most economical hoist model for a given application as recognized by Yale and the Hoist Manufacturer's Institute (HMI).

Yale agrees, in general, with the classification standards given by HMI and has patterned its Yale hoist performance rating similarly. Yale wire rope hoists have been grouped into the following categories:

- H3 - Yale H3 class hoists satisfy the HMI requirements for the H#, H2 and H1 applications.
- H4 - Yale H4 class hoist satisfy the HMI requirements for applications where the total running time of the hoist does not exceed 35% of the work period.
- H5 - Yale H5 class hoists satisfy the HMI requirements for H5 applications and those H4 applications where the total running time of the hoist exceeds 35%.

All Yale wire rope hoists classified as H3 and H4 are furnished with 30 minute duty rated motors as standard. The H5 class equipment is furnished on application and typically includes continuous duty motors and eddy current braking. Please consult the factory for this application.

Please refer to ANSI/ASME "Electric Wire Rope Hoists" for a detailed explanation of ANSI/ASME duty classifications adopted from HMI 100-74.

**When Replacement Parts Are Needed, Order Only YALE® Factory Engineered Parts**

PARTS AND INSTRUCTION MANUAL - EW SERIES  
REVISED SEPTEMBER 1996



## YALE HOIST DUTY SERVICE CLASSIFICATIONS

Yale Hoist Duty Class	Typical Areas of Application	Operational Time Ratings			
		Uniformly Distributed Work Periods		Infrequent Work Period Hoist Running 50% Time	
		(3) Max. On Time Min./Hr.	(4) Max. No. of Starts/Hr.	(5) Max. Time From Cold Start Min.	(6) Max. No. of Starts
H3	General Machine Shop, fabricating, assembly, storage and warehousing. Where loads and utilization are randomly distributed, with total running time of equipment not exceeding 15-25% of the work period.	15	150	60	200
H4	High volume handling in steel warehousing, general machine shops, fabricating, assembly, mills and foundries. Total running time does not exceed 35% of work period. Loads at or near rated capacity frequently handled.	21	300	30	300
H5	Material bulk handling in combination with buckets, magnets or heavy attachments. Often cab operated. Duty cycle exceed 35% and approaches continuous operation. User must specify exact details of operation including attachment weights.	Up to continuous	600	(Not Applicable)	(Not Applicable)

**When Replacement Parts Are Needed, Order Only YALE® Factory Engineered Parts**

**PARTS AND INSTRUCTION MANUAL - EW SERIES**

REVISED SEPTEMBER 1996

5



## **REPAIR PARTS ORDERING INFORMATION**

This parts and instruction manual contains information required to install and maintain your Yale EW Series Electric Hoist. To insure prompt service, each repair parts order should be placed with your local distributor, and must contain the following information:

Please give all information listed below in items 1 through 5. This will enable your distributor to fill your order promptly.

1. Give complete data from hoist nameplate, including hoist serial number, model number, voltage, frequency, and hertz.
2. Give part numbers, description and quantity of parts required.
3. Give correct shipping destination.
4. For ordering motor repair parts, give all data on the hoist and motor nameplates.
5. If hoist has been purchased for a special application or environment (such as plating, spark resistant, special hook, special controls, etc.), some of the standard parts listed in this manual may not apply and some special parts may not be shown. In such cases, you should contact the factory or your nearest Yale authorized repair station for assistance in ordering parts. A full description of the special application or environment for which the hoist has been adapted will be required.

### **Hoist Serial Numbers**

The hoist serial number is stamped in the suspension frame and nameplate. Trolley serial numbers are stamped on the trolley side plate. The nameplates also designate the model number, capacity, speed, current characteristics, and service rating of the hoist or trolley.

### **Return of Parts**

If it becomes necessary to return the complete hoist or certain parts to the factory, a letter requesting such a return is necessary. This letter should contain an explanation for requesting the return. A return authorization will be issued giving you clearance for returning the hoist or parts to the factory.

**When Replacement Parts Are Needed, Order Only YALE® Factory Engineered Parts**

PARTS AND INSTRUCTION MANUAL - EW SERIES  
REVISED SEPTEMBER 1996





## Recommended Spare Parts List For One Year Operation

Unit Model Number \_\_\_\_\_ Serial Number \_\_\_\_\_  
 Customer P.O. \_\_\_\_\_ Customer Name \_\_\_\_\_  
 Voltage \_\_\_\_\_ Order Number \_\_\_\_\_

The following parts are unique to each hoist model. Use the parts manual section indicated below. Find the part number for your model hoist on parts list in front cover and complete the form below.

ITEM	REF. SECTION	PART NUMBER	QTY./UNIT
WIRE ROPE ASSEMBLY .....	1610	64601192-00	1
LOAD BRAKE SPARE PARTS KIT			
BEW .....	1340	6460192-00	1
BEW X & CEW .....	1340	6460202-00	1
CEW X & DEW .....	1340	6460212-00	1
DEW X & EEW .....	1340	6460222-00	1
EEW X & FEW .....	1340	6452334-00	1
GEARCASE SEAL KIT			
BEW .....	1340	6460142-00	1
BEW X & CEW .....	1340	6460142-00	1
CEW X & DEW .....	1340	6460152-00	1
DEW X & EEW .....	1340	6460172-00	1
EEW X & FEW .....	1340	6460172-00	1
MOTOR BRAKE (DIRECT ACTING)			
MAGNET COIL ASSEMBLY .....	1351	_____	1
ROTATING DISC .....	1351	_____	1
MOTOR BRAKE (SOLENOID ACTUATED)			
SOLENOID COIL .....	1351	_____	1
ROTATING DISC .....	1351	_____	1
LIMIT SWITCH CONTACTS			
TRAVELING NUT .....	1420/30	640205/-00	2
ROTATING CAM .....	1420/30	6492221-01	2
UPPER PLUGGING .....	1410	Select Complete Switch	1
REVERSING CONTACTORS			
HOIST .....	2310	_____	1
.....	2310	_____	2
TROLLEY .....	2310	_____	1
.....	2310	_____	2
CONTROLS			
PUSH BUTTON COMPONENTS .....	2710/80	_____	1
MAINLINE CONTACTOR .....	2310	_____	1
TRANSFORMER XFMR .....	2330	_____	1
TRANSFORMER FUSE .....	2330	_____	1
CONTROL RELAYS .....	2320	_____	1
BOTTOM HOOK .....	1640	_____	1
HOOK LATCH KIT .....	1640	_____	1

**When Replacement Parts Are Needed, Order Only YALE® Factory Engineered Parts**

PARTS AND INSTRUCTION MANUAL - EW SERIES

REVISED SEPTEMBER 1996



# INSTALLATION INSTRUCTIONS

---

Before the unit is shipped from the factory it is rigidly tested and carefully adjusted for proper operation. However, the following points must be checked to insure correct installation and avoid damage to the hoist.

1. **SUSPENSION:** Suspend the hoist following the installation procedures for the type of suspension used on your hoist. See page 10.
2. **ROPE AND DRUM:** Check the hoist rope for any signs of damage and make sure it lies properly in the grooves of the drum and sheaves. Make sure the rope is well lubricated. (See chart on page 17.)

**BEFORE OPERATING THE HOIST, REMOVE THE WOODEN SHIPPING WEDGE LOCATED ON TOP OF THE ROPE BETWEEN THE DRUM AND SUSPENSION FRAME.**

3. **LUBRICATION:** Every attempt has been made to ship the hoist with the proper amount of lubricating oil in the gearcase. Before placing the unit in operation, remove the level plug in the gear housing and check the oil level. The oil should be level with the level hole. If more oil is needed, consult the Lubrication Chart on page 17. Also make sure breather plug hole is cleared.
4. **CURRENT SUPPLY:** make sure the electric current supply corresponds with the rating listed on the hoist nameplate. Make sure duty cycle capabilities of hoist are fully understood by all operators.
5. **ELECTRICAL CONNECTIONS:** Open the control box and check all the electrical connections to be sure they are tight and that none of the hardware vibrated loose during shipment.

Connect the power lines to the point on the reversing switch indicated by the tag and remove tag. If current collectors are used, be sure they make good contact with the conductor bars.



## Caution

**THE HOIST MUST BE GROUNDED. TO DO THIS, CONNECT ONE END OF THE GREEN WIRE IN THE POWER CORD TO A SOLID GROUND AND THE OTHER END TO THE SPECIFIED GROUNDING LUG PROVIDED ON THE HOIST.**

**When Replacement Parts Are Needed, Order Only YALE® Factory Engineered Parts**

**PARTS AND INSTRUCTION MANUAL - EW SERIES  
REVISED SEPTEMBER 1996**



## INSTALLATION INSTRUCTIONS (CONTINUED)

### 6. PUSH BUTTON CONTROL:



**Caution**

ON POLY PHASE AC HOISTS, IT IS IMPOSSIBLE TO KNOW HOW TO CONNECT THE POWER LINE FOR CORRECT DIRECTION OF THE HOOK TRAVEL.

TO INSURE CORRECT OPERATION OF THE SAFETY LIMIT STOPS, IT IS VERY IMPORTANT THAT THE HOOK TRAVEL IS IN THE HOISTING DIRECTION WHEN THE UP BUTTON IS PRESSED. IF IT IS NOT, INTERCHANGE TWO OF THE LINE WIRES FOR 3-PHASE. IF THE HOIST IS OPERATED WITH INCORRECT POWER CONNECTIONS, THE SAFETY LIMIT STOPS WILL BE INEFFECTIVE AND SERIOUS HOIST DAMAGE AND DANGEROUS ACCIDENTS MAY RESULT.

### Adjustments of Limit Switches

1. UPPER PLUGGING LIMIT SWITCH (NOT USED ON WINCH MODELS): After the hoist is determined to be running in the proper direction, lower the hook to approximately eight feet (8) below the hoist. Check the limit switch by running the hook upward and lifting the rod or weight by hand. When the rod or weight is lifted from one-half inch ( $\frac{1}{2}$ ) to two inches (2) the hoist should cut-off. Any further lifting of the rod or weight should close the lowering circuit and cause the hook to lower.
2. TRAVELING NUT UPPER AND LOWER LIMIT SWITCH:



**Warning**

EACH STEP OUTLINED BELOW MUST BE FOLLOWED FOR PROTECTION AGAINST ELECTRICAL SHOCK AND INJURY FROM MOVING COMPONENTS.

To adjust the traveling nut switches, or to set them at other levels:

- a. Remove all electrical power from the hoist.
- b. Loosen the limit switch cover screws and remove the cover.
- c. Slide the locking plate from under the traveling nuts and turn both nuts until they meet at the center of the shaft.
- d. Replace the locking plate under the traveling nuts.
- e. Replace cover and hand tighten cover screws.
- f. Apply electrical power to the hoist.
- g. Run hoist to the desired lower limit.



**Warning**

AT LEAST ONE WRAP OF ROPE MUST REMAIN ON THE DRUM IN THE LOWEST POSITION.

- h. Remove electrical power from the hoist and remove the switch cover.
- i. Slide the locking plate from under the traveling nuts.

**When Replacement Parts Are Needed, Order Only YALE® Factory Engineered Parts**

PARTS AND INSTRUCTION MANUAL - EW SERIES

REVISED SEPTEMBER 1996

9



## INSTALLATION INSTRUCTIONS (CONTINUED)

- j. Rotate the lower nut (the one nearest to a contact) until it contacts. Continue rotating until the microswitch can be heard to trip.
- k. Replace locking plate under the nuts. (Slight adjustment of traveling nuts may be necessary).
- l. Replace cover and hand tighten cover screws.
- m. Apply power and check lower limit switch operation. If minor adjustment is necessary, repeat steps (h) through (m), rotating nut one step at a time until proper adjustment is accomplished.
- n. Repeat steps (g) through (m) to adjust the upper limit switch, by substituting upper for lower in steps (g) through (j).



### Warning

**WHEN UPPER PLUGGING LIMIT SWITCH IS USED, MAKE SURE TRAVELING NUT (OR GEARED) LIMIT SWITCH TRIPS FIRST, ALLOWING THE ROD OR WEIGHT TYPE SWITCH TO ACT AS THE BACK-UP LIMIT.**

### 3. GEARED TYPE UPPER AND LOWER LIMIT SWITCH:

- a. If geared type upper and lower switch is used, see Section 1420 for installation, adjustment and maintenance instructions.
- b. Note warnings in paragraph 2 above.

## Basic Suspensions

The basic hoist suspension types are: lug mounted, frame mounted (various types), plain trolley, hand chain operated trolley, single beam under running motorized trolley, and top running motorized trolley for double rails. Before connecting hoist to supporting structure, or mounting on beam or rail, make sure supporting structure has adequate strength to safely support the loading which will be imposed.

When installing lug mounted or frame mounted types, make sure hoist is bolted securely in place with the proper size bolts, that it is level, that nuts on mounting hole bolts are tightened securely, and the lockwashers, or other means of locking the nuts are used.

If hoist is furnished with a motorized trolley, record the serial number in this book for future reference, and refer to the trolley manual included.

Hand hoist furnished with plain, hand chain operated, or under running motorized trolley, first determine the beam size on which the trolley is to be used, then refer to trolley adjustment instructions below for proper spacer arrangements. On top running motorized trolleys, make sure rail size is correct for wheels and that distance between rails is correct for trolley throughout entire rail lengths.

**When Replacement Parts Are Needed, Order Only YALE® Factory Engineered Parts**

PARTS AND INSTRUCTION MANUAL - EW SERIES  
REVISED SEPTEMBER 1996



## **INSTALLATION INSTRUCTIONS** (CONTINUED)

---

### **Trolley Adjustment**

All Yale under running trolleys are properly adjusted at the factory to fit the I-Beam size stated on the order.

**NOTE:** *When disassembling the trolley for installation on the I-Beam, take note of the arrangement of the spacers and washers for correct reassembly.*

For installation on I-Beam other than the size preset at the factory, follow the instructions listed below.

Measure the I-Beam flange width and temporarily install the trolley side plates on the hoist before installation to determine the exact distribution of washers.

The distance between track wheel flanges should be 3/16 inches greater than the beam flange width for straight runway beams, and 3/16 to 1/4 inches on runway systems that include sharp curves. To keep the hoist centered under the I-Beam, the number of washers between the side plates and the hoist lug should be the same or differ only by one (1) washer. The distribution of washers outside the trolley side plates is unimportant except that the total number used must be sufficient to keep the nuts engaged.

**NOTE:** *When installing hoist and trolley on beam, tighten nuts snugly so that the trolley side plates are parallel and vertical.*



**Caution** BE SURE THERE IS A LOCKWASHER UNDER EACH NUT.

After the hoist and trolley are installed on the I-Beam, operate the trolley over the entire length of the beam with a capacity load to be sure that adjustment and operation is satisfactory. Then tighten all side plate nuts to maximum standard torque for bolt size used.

**When Replacement Parts Are Needed, Order Only YALE® Factory Engineered Parts**

PARTS AND INSTRUCTION MANUAL - EW SERIES  
REVISED SEPTEMBER 1996



# PREVENTIVE MAINTENANCE SCHEDULE

---

The required periods between inspections will vary due to the wide range of duty cycles and operating conditions encountered with type of equipment. The following recommended inspection periods are based on duty of specified service rating with single shift operation (40 hours per week) under normal environmental conditions. If the hoist is used under adverse environmental conditions it should be inspected more frequently.

## Daily Inspection

Inspect the following items before operating hoist:

1. **MANUAL CONTROLS:** Check all manual controls for proper operation.
2. **ELECTRICAL CONNECTIONS:** Check for worn or frayed wires, for loose connections and for damage to, or improper operation of, push button assembly.
3. **LIMIT SWITCH:** Check the upper and lower limit switch by running the hook without load, and at the slowest speed obtainable, to the maximum up and maximum down positions. Then test with increasing speeds up to maximum. The switch should shut the hoist off before the bottom block contacts the rod or weight type limit switch at the upper extreme. 1-1/2 wraps of rope should remain on the drum at the shut-off point at the lowest extreme. If adjustment is necessary, see page 9.
4. **HOOK:** Check for cracks or deformation. Check for damaged or missing latch. A bent or twisted hook indicates overloading or abuse of unit. Other load bearing components of the hoist or trolley should be inspected if overloading is apparent or suspected. The bottom hook must swivel freely.
5. **WIRE ROPE:** Check for proper seating in drum grooves. Check for wear, unstranding, fraying, kinks, or broken wires in the wire rope, and condition of end connections. (If damage is noted, see wire rope instructions under monthly inspection.)
6. **HOOK DRIFT:** With a load, the hook should stop promptly when the push button is released. Hook drift of more than 2 inches indicates the motor brake is malfunctioning. (See quarterly and annual inspection instructions for more details.)
7. **UNUSUAL CONDITIONS:** Excessive noise, oil leaks, etc. should be investigated.



**Caution**

**DO NOT OPERATE THE HOIST IF ABOVE INSPECTION INDICATES THAT MAINTENANCE IS NEEDED.**

**When Replacement Parts Are Needed, Order Only YALE® Factory Engineered Parts**

**PARTS AND INSTRUCTION MANUAL - EW SERIES  
REVISED SEPTEMBER 1996**



## **PREVENTIVE MAINTENANCE SCHEDULE (CONT'D)**

### **Monthly Inspection**

1. ALL ITEMS UNDER DAILY INSPECTION.
2. LUBRICATION: Check the level and condition of the gearcase lubricant. The level must be maintained at the gearcase level plug. If the level is low, check for leaks. Replace gaskets and shaft seals if necessary. An excessively black color lubricant indicates a chemical change in the lubricant caused by excessive heat from the load brake, which in turn is caused by heavy duty cycles. Lubricant that is very black in color must be replaced to prevent shortened life of drive components. Lubricate wire rope and other points as required. (See chart on page 17.)



**Caution** FOR OPTIMUM LUBRICATION AND LOAD BRAKE COOLING, OIL LEVEL MUST BE MAINTAINED AT THE LEVEL PLUG.

3. HOOK: Check hook retaining nuts and collars, and means used to secure them. Replace hook if throat opening is in excess of maximum shown in table on page 16, or if there is 10 degrees or more twist from normal plane of hook.
4. LOAD BRAKE: check the function of the load brake by lifting a light load (approximately 25% of rated load) 6 to 12 inches above the floor. Disconnect electrical power and manually open the motor brake. The load may "creep" slowly while the motor brake is held open. This is normal. However, if the load falls to the floor the instant the motor brake is released, the load brake is not functioning properly and should be replaced.
5. CONTACTORS: Check for burned or badly pitted contacts.
6. PUSH BUTTON: Check the ground connections to be sure that the wire cores from the push button cable and the power cord are secured. Tighten the grounding screw and replace the lockwasher if it is missing.
7. BEARINGS: Check all bearings for noisy operation, which is an indication of wear.
8. HARDWARE: Check for loose bolts, nuts and rivets.
9. WIRE ROPE: Check conditions of wire rope using inspection checklist. (See instructions, page 18.) Lubricate per chart on page 17 as needed.



**Warning** NEVER ALLOW WIRE ROPE TO OPERATE DRY.

10. WARNING LABELS: Check for absence or illegibility of warning decals and tags and replace if necessary.

**When Replacement Parts Are Needed, Order Only YALE® Factory Engineered Parts**

PARTS AND INSTRUCTION MANUAL - EW SERIES  
REVISED SEPTEMBER 1996



## **PREVENTIVE MAINTENANCE SCHEDULE (CONT'D)**

---

11. **SUPPORTING STRUCTURE OR TROLLEY:** If used, should be checked for continued ability to support the imposed loads. Check for loose suspension or support bolts, axle nuts, etc.
12. **INSPECTION CHECKLIST:** Fill out inspection checklist at the back of this manual, sign, date and file for future reference.

### **Quarterly Inspection**

1. **ALL ITEMS UNDER DAILY AND MONTHLY INSPECTIONS.**
2. **GEARING:** Remove gearbox inspection cover and visually inspect gearing for excessive or uneven wear of the gear teeth. Replace if necessary.
3. **MOTOR BRAKE:** Check for excessive or uneven disc wear. On direct acting, check for excessive magnet gap (see Section 1351). On solenoid actuated, clean solenoid plunger seat and check for uneven seating between the plunger and coil. Lubricate brake cams, pivot studs, and linkage as required (see Section 1351).

### **Annual Inspection**

1. **ALL ITEMS UNDER DAILY, MONTHLY AND QUARTERLY INSPECTIONS.**
2. **HOOKS:** Magnetic particle or other suitable crack detecting inspection should be performed if need is indicated by external appearance. Check for loose retaining nuts and collars.
3. **LOAD BEARING PARTS:** Check for worn, cracked or distorted parts, such as suspension housings, outriggers, clevises, yokes, hook blocks, suspension bolts, shafts, locking devices and bearings on hoist (also on trolley, if so equipped).
4. **LOAD BRAKE (for all chassis and duty services except EEW - H3 and FEW - H4):** Check load brake for worn discs, check operation of one way holding pawl. If either brake disc is worn 1/16 inches or more replace ratchet and disc assembly. New discs measure 3/16 inches thick. (See page 16.)
5. **LOAD BRAKE (for EEW - H3 and FEW - H4):** Check load brake for worn discs, check operation of one way sprag holding clutch. If either brake disc is worn 1/32 inches or more, replace ratchet and disc assembly. New discs measure 3/16 inches thick. (See page 16.)
6. **MOTOR BRAKE:** Check for excessive or uneven disc wear. On direct acting, check for excessive magnet gap (see Section 1351). For solenoid actuated, clean solenoid plunger seat and check for uneven seating between plunger and coil. Lubricate brake cams, studs and linkage as required.

**When Replacement Parts Are Needed, Order Only YALE® Factory Engineered Parts**

**PARTS AND INSTRUCTION MANUAL - EW SERIES  
REVISED SEPTEMBER 1996**





## **PREVENTIVE MAINTENANCE SCHEDULE (CONT'D)**

7. **LOAD LIMITING DEVICE:** If a load limiting device is used, check device with 150% of rated load. Attempt to raise the load. If the load limiting device is working properly the load should not move, or move only slightly. If the unit raises the load immediately, lower the load, then repair or replace the load limiting device.



### **Caution**

**PRIOR TO TESTING, ALL SUPPORTING STRUCTURES, ANCHORAGES, AND/OR SUSPENSIONS MUST BE APPROVED BY THE APPOINTED PERSON FOR THE TEST LOADS USED.**

8. **WIRING AND TERMINALS:** See that all connections are tight. Terminals are to be securely crimped to wires and the insulation sound. Bent terminals can usually be straightened to provide a tight fit. Replace terminals or wire if necessary.
9. **SHEAVES AND DRUMS:** Inspect rope sheaves and drums for excessive wear. When the groove of a sheave or rope drum becomes worn excessively it should be replaced. Worn grooves on the drum or sheave can greatly reduce the useful life of the hoisting rope.
10. **BEARING LUBRICATION:** The motor, sheave and outer drum bearings are packed with grease at the factory and normally will not need to be lubricated. If conditions require, repack with grease as needed.
11. **INSPECTION CHECKLIST:** Fill out inspection checklist at the back of this manual, sign, date and file for future reference.

### **Function Testing After Repair**

After repair or replacement of parts, function test hoist by operating unloaded hoist into both upper and lower limits, first with slowest speed possible, then with increasing speeds up to maximum. Limit switch mechanisms must be adjusted so they will trip in sufficient time to prevent damage to any part of the hoisting arrangement. See instructions for adjustment of limit switches on page 9. Then test operation of hoist and brake by lifting 100% of rated load. (A normal load lifted may be substituted if no load bearing parts were altered.) If the gear train was disassembled, check the load brake per item 4 of the monthly inspection instructions. If hoist is equipped with a load limiting device, and load bearing parts have been altered, the first test load should be only 100% of rated load. The test should be prepared by the person responsible and kept on file for future reference.

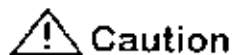

### **Caution**

**PRIOR TO TESTING, ALL SUPPORTING STRUCTURES, ANCHORAGES, AND/OR SUSPENSIONS MUST BE APPROVED BY THE APPOINTED PERSON FOR THE TEST LOADS USED.**

**When Replacement Parts Are Needed, Order Only YALE® Factory Engineered Parts**

**PARTS AND INSTRUCTION MANUAL - EW SERIES  
REVISED SEPTEMBER 1996**



# PREVENTIVE MAINTENANCE SCHEDULE (CONT'D)

## Hook Dimensions (Except FEW)

CAPACITY IN TONS	E (in.) NORMAL	E (in.) MAXIMUM
½	1 1/32	1 7/32
1	1 9/64	1 11/32
2	1 21/64	1 9/16
3	1 15/16	2 1/4
5	1 15/16	2 1/4
6	1 15/16	2 1/4
7 ½	1 15/16	2 1/4
8	3 1/16	3 9/16
10	3 1/16	3 9/16
12	3 1/16	3 9/16
15	3 1/16	3 9/16
20	3 ½	4 5/64
25	3 ¾	4 1/4
30	4 1/4	4 ¾



**E** OPENING WITH LATCH



**Warning**

IF "E" EXCEEDS MAXIMUM SHOWN IN TABLE. REPLACE HOOK AND CHECK OTHER LOAD BEARING PARTS

## Hook Dimensions (FEW)

CAPACITY IN TONS	E (in.) NORMAL	E (in.) MAXIMUM
5,6&7 ½	1 31/32	2 11/32
10	3 1/16	3 9/16
15 & 20	3 ½	4 9/64
25	3 ¾	4 33/64
30	4 1/4	4 29/32

## Load Brake Disc Wear - Standard Load Brakes

MODEL	A DIMENSION	MAXIMUM WEAR ALLOWED
EW SERIES	3/16 (in.)	1/16 (in.)

NEW RATCHET AND DISC ASSEMBLY

DISC BONDED TO RATCHET



When Replacement Parts Are Needed, Order Only YALE® Factory Engineered Parts

PARTS AND INSTRUCTION MANUAL - EW SERIES  
REVISED SEPTEMBER 1996



# PREVENTIVE MAINTENANCE SCHEDULE

(CONT'D)

## Lubrication

### EW Series Hoists

PART	LUBRICANT	LUBRICATION POINT	LUBRICATION INSTRUCTIONS	DRAIN POINT
Gear Case	Chevron, Hydraulic Tractor Fluid or Equal	Fill from vent hole on top of gear case	BEW-H4 1 QT. BEW-H3 & CEW-H4 3 PTS. CEW-H3 & DEW-H4 4 QTS. DEW-H3 & EEW-H4 8 QTS. QEW 8 QTS. REW 8 QTS. SEW 10 QTS.	Socket head plug in bottom of gear case
Gear Case	Chevron RPM Universal Gear Lube 85W-140 or Equal		EEW-H3 & FEW 7 GAL.	
Motor Brake Linkage	Light Machine Oil DTE Oil Heavy Medium	Pivot Linkage	Solenoid Actuated Apply one or two drops on the linkage	
Wire Rope	Chevron 100 CB, or other prepared cable lubricant Mobilnac 325 NC	Wire Rope	Light coat of lubricant	

\* All units equipped with load brake unless otherwise specified.

### Plain and Hand Chain Operated Trolleys

TEMPERATURE RANGE

Alamite Fittings	Chevron Dura-Lith Grease EP NLGI 2	Lubricant Pour	-25°F Max -260°F
Ball Valve Oil Holes	Light machine oil	Hoist Ambient Temp.	0° - 120°F

### RT, TR, TT, and TX Series Trolleys

PART	LUBRICANT	LUBRICATION POINT	LUBRICATION INSTRUCTIONS	DRAIN POINT
Gear Case	Shell Velvata Oil J28 or Equal	Socket head plug in side of gear case	Fill until lubricant is level with hole	Socket head plug in bottom of gear case
RT				
TR, TX	Chevron RPM Universal Gear Lube 85W-140 or Equal			
TT	Chevron Dura-Lith Grease EP NLGI 2 or Equal			
Track Wheel Pinion & Gear Teeth	Chevron Dura-Lith Grease EP NLGI 2 or Equal	Pinion & Gear Teeth	Depending on applications Light coating of grease	

When Replacement Parts Are Needed, Order Only YALE® Factory Engineered Parts

PARTS AND INSTRUCTION MANUAL - EW SERIES  
REVISED November 1996

17



## PREVENTIVE MAINTENANCE SCHEDULE (CONT'D)

### Wire Rope Inspection

All wire rope should be inspected once a month and a signed and dated inspection report maintained. The inspection checklists at the back of this manual can be used to record these inspections. Wire rope should be replaced if any of the following conditions are noted.

1. Twelve randomly distributed broken wires in one rope lay, or four broken wires in one strand in one rope lay.
2. Wear of one-third (1/3) of the original diameter of outside individual wires.
3. Kinking, crushing, birdcaging or any distortion of the wire rope structure.
4. Evidence of heat damage.



"Broken Wires"



"Kinked"



"Bird Cage"

5. Reductions from nominal diameter of more than the following values:

New Rope Diameter	Maximum Reduction
5/16 inch and under	1/64 inch
3/8 inch through 1/2 inch	1/32 inch
9/16 inch through 3/4 inch	3/64 inch
7/8 inch through 1-1/8 inch	1/16 inch

6. Rope sockets should be inspected for broken wires. If broken wires are noted, the rope should be replaced.



#### Caution

REPLACEMENT WIRE ROPE SHOULD BE THE SAME SIZE, GRADE AND CONSTRUCTION AS THE ORIGINAL WIRE ROPE. BEFORE REPLACING WIRE ROPE, READ PROCEDURE ON PAGE 19. AFTER WIRE ROPE REPLACEMENT CHECK FOR PROPER LIMIT SWITCH OPERATION (SEE PAGE 9).

When Replacement Parts Are Needed, Order Only YALE® Factory Engineered Parts

PARTS AND INSTRUCTION MANUAL - EW SERIES  
REVISED SEPTEMBER 1996



## PREVENTIVE MAINTENANCE SCHEDULE (CONT'D)



**Warning**

ROPE PILE-ON HOISTING DRUM WILL SEVERELY DAMAGE THE HOISTING ROPE. IF THIS CONDITION IS NOTED, THE HOISTING ROPE SHOULD BE INSPECTED ACCORDING TO THE ABOVE PARAGRAPH ON WIRE ROPE INSPECTION. IF DAMAGED ROPE IS FOUND, CHECK DRUM AND FRAME MEMBERS FOR DAMAGE.

### How To Measure Wire Rope

The correct diameter of a wire rope is the diameter of a circumscribed circle which will enclose all the strands. It is the largest cross-sectional measurement as illustrated below. The measurement should be made carefully with calipers. The illustrations below show the correct and incorrect method of measuring the diameter of wire rope.

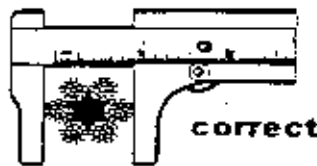

### Procedure for Reeving Wire Rope on Drum

#### DOUBLE REEVED UNITS

**NOTE:** *Traveling nut switch must be preset before reeving, per Steps (a) through (e) on Page 9 and re-adjusted per Steps (f) through (n) after reeving.*

1. Anchor the rope in the drum on one side. Install rope retainer.
2. Stretch out rope to make sure there are no twists or kinks.
3. Reeve the free end of the rope through the bottom block and all sheaves. (See Pages 16 & 17.)
4. Anchor the free end of the rope in the other side of the drum. Install rope retainer.
5. Push the "UP" button to reeve both sides of the drum, making sure there is enough force on the rope to insure proper reeving in all drum grooves.

**NOTE:** *When the bottom block is raised to the upper limit, the block should be at the mid-point of the ungrooved portion of the drum and even with idler sheave. If this is not so, the unit is reeved incorrectly.*

**When Replacement Parts Are Needed, Order Only YALE® Factory Engineered Parts**

PARTS AND INSTRUCTION MANUAL - EW SERIES  
REVISED SEPTEMBER 1996



## **PREVENTIVE MAINTENANCE SCHEDULE (CONT'D)**

### **SINGLE REEVED UNITS**

1. Anchor the rope in the drum. Install rope retainer.
2. Stretch out rope to make sure there are no twists or kinks.
3. Reeve the free end of the rope through the bottom block. (See next page.)
4. Attach the dead end of the rope to the suspension frame.
5. Push the "UP" button to reeve the drum making sure there is enough force on the rope to insure proper reeving in all drum grooves.



#### **Warning**

**ALL UNITS MUST HAVE A MINIMUM OF ONE WRAP OF WIRE ROPE ON THE DRUM WHEN THE BOTTOM BLOCK IS IN THE LOWEST POSITION.**

### **REEVING TYPES**

Yale powered wire rope hoists and winches are reeved in various ways to gain desired advantages. Proper reeving insures maximum life of the hoist drum, wire rope, and bottom block assembly while obtaining the best characteristics of capacity, lift, and speed for the basic unit.

Reeving is either "single" or "double", i.e. one or two ropes coming from the drum. Standard headroom hoists are single reeved, close headroom hoists are double reeved. Part designates the mechanical use of each rope coming from the drum.

The table and drawings pictured on the next page show the characteristics of each principal method of reeving.

The advantages of single reeved units are fewer ropes and longer lifts from comparable units. Advantages of double reeved units include minimum lateral hook drift (keeping load in the same approximate position in relation to the drum and beam) and a lower hoist headroom requirement.

**When Replacement Parts Are Needed, Order Only YALE® Factory Engineered Parts**

**PARTS AND INSTRUCTION MANUAL - EW SERIES  
REVISED SEPTEMBER 1996**



# PREVENTIVE MAINTENANCE SCHEDULE (CONT'D)

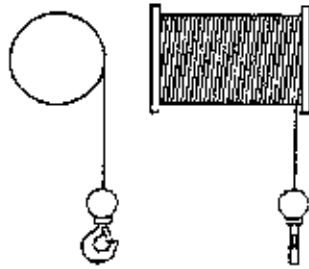

1 part single  
S1

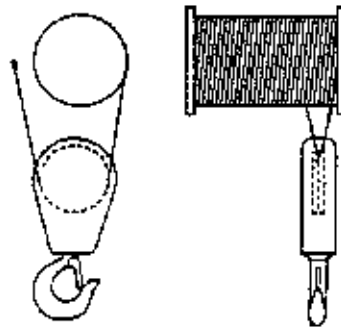

2 part single  
S2

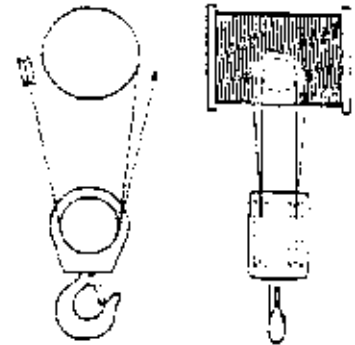

4 part single  
S4

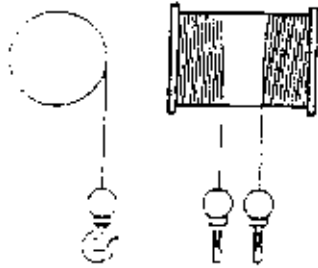

twin rope (1 part double)  
D1

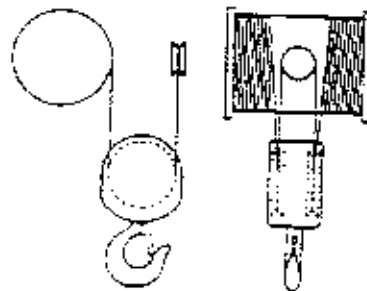

2 part double  
D2

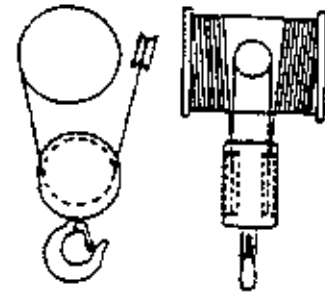

2 part double  
P2

Reeving on FEW and all TR models

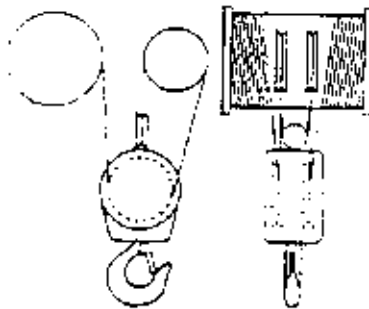

3 part double  
D3

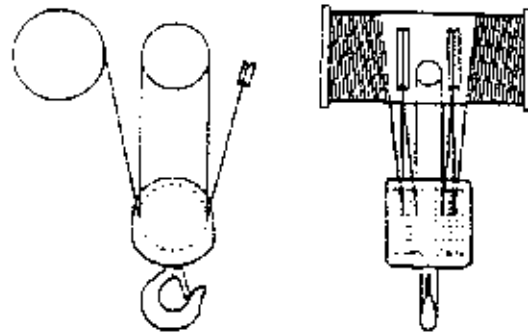

4 part double  
D4

When Replacement Parts Are Needed, Order Only YALE® Factory Engineered Parts

PARTS AND INSTRUCTION MANUAL - EW SERIES  
REVISED SEPTEMBER 1996



# **PREVENTIVE MAINTENANCE SCHEDULE (CONT'D)**

## **Reeving Types**

**When Replacement Parts Are Needed, Order Only YALE® Factory Engineered Parts**

**PARTS AND INSTRUCTION MANUAL - EW SERIES  
REVISED SEPTEMBER 1996**





## **PREVENTIVE MAINTENANCE SCHEDULE (CONT'D)**

### **Disassembly (For all chassis and duty service except EEW X & FEW)**

 **Caution** BEFORE DOING MAINTENANCE WORK ON THIS HOIST, READ THE FOLLOWING INSTRUCTIONS THOROUGHLY. REFER TO THE REPLACEMENT PARTS SECTION FOR PARTS IDENTIFICATION.

To completely disassemble the hoist, follow the disassembly procedures in the order listed.

To disassembly any one specific part of the hoist, follow the instructions for that specific section.

#### 1. REMOVE HOIST ROPE, BOTTOM BLOCK OR BOTTOM HOOK.

##### a. Standard Headroom Hoist

- 1) Remove or re-adjust traveling nut or geared limit to negate lower limit (see instructions (a) through (f) on page 9).
- 2) Operate hoist in down direction until no cable remains on the drum. Remove rope retainers and pull rope sockets from the drum.
- 3) Remove power from the hoist.
- 4) Disassemble bottom block and remove hoist rope.
- 5) Remove limit switch weight from the hoist cable.
- 6) Remove pin holding the cable in the hoist frame.

##### b. Low Headroom Hoist

- 1) Follow procedures in 1.a. - 1), 2) and 3).
- 2) Remove pin holding equalizer sheave yoke in hoist frame.
- 3) Remove axle holding the sheave in the yoke and remove cable.

#### 2. REMOVE MOTOR BRAKE (DIRECT ACTING).

 **Caution** CUT-OFF ALL POWER TO THE HOIST BY DISCONNECTING THE POWER FEED LINE BEFORE ATTEMPTING SERVICE OR REPAIR.

- a. Disconnect coil wire leads. Remove cover screws and cover.
- b. Remove four socket head screws holding brake to gear case. Remove brake.
- c. Remove hub retaining ring from shaft. Remove hub.

#### 3. REMOVE GEAR CASE AND DRIVE SHAFT.

- a. If possible, run hoist in down direction and clear all rope from the hoist drum.
- b. Follow procedure in 2 to remove motor brake.

**When Replacement Parts Are Needed, Order Only YALE® Factory Engineered Parts**

PARTS AND INSTRUCTION MANUAL - EW SERIES  
REVISED SEPTEMBER 1996



## **PREVENTIVE MAINTENANCE SCHEDULE (CONT'D)**

- c. Before removing gear case, the hoist rope drum must be securely restrained within the suspension frame. (Note that the hoist motor does not have to be removed at this time, but must be removed before the gear case can be reassembled to the hoist.)
- d. Pry the gear case from the frame side plate. Continue to pull the gear case straight back from the frame until the entire drive shaft has been removed from the drum.

The gear case assemblies can be very heavy. If possible, it is best to support their weight prior to removal.

### **4. REMOVE HOIST MOTOR, MOTOR ADAPTER.**

- a. If possible, run hoist in down direction and clear all rope from the hoist drum.
- b. Remove all power from the hoist.
- c. Disconnect motor leads in control box.
- d. Disconnect flex conduit from motor to control box.
- e. Remove four bolts and lockwashers holding motor to motor adapter.
- f. Pry the motor from the motor adapter.
- g. Before removing the motor adapter the hoist drum must be securely restrained within the suspension frame.
- h. Remove the four bolts and lockwashers holding the motor adapter to the frame side plate.
- i. Pry the motor adapter from the frame side plate.

The motors and motor adapters can be very heavy. If possible, it is best to support their weight prior to removal.

### **5. REMOVE HOIST ROPE DRUM.**

- a. Follow procedures in 1, 2, 3 and 4 to remove gear case and drive shaft, motor, and motor adapter.
- b. Remove rope drum from suspension frame.

### **6. REMOVE LIMIT SWITCH, TRAVELING NUT OR GEARED.**

- a. Geared Upper and Lower Limit Switch
  - 1) Disconnect all power from hoist.
  - 2) Remove the cover from the limit switch and disconnect the wiring. Note the color coding or tag the wires so they can be reconnected correctly. Loosen the cord fitting and remove the cord.
  - 3) Remove the three bolts and lockwashers that hold the limit switch assembly to the gear case. Remove the limit switch assembly from the gear case.
  - 4) Refer to Section 1420 if further disassembly of the limit switch is necessary.

**When Replacement Parts Are Needed, Order Only YALE® Factory Engineered Parts**

PARTS AND INSTRUCTION MANUAL - EW SERIES  
REVISED SEPTEMBER 1996



## **PREVENTIVE MAINTENANCE SCHEDULE (CONT'D)**

### **b. Lever Operated Upper Limit Switch**

- 1) Disconnect all power from hoist.
- 2) Remove the bolts holding the limit switch bracket to the hoist and remove the limit switch assembly.
- 3) Loosen the clamping screw holding the hub on the limit switch shaft and remove the hub and lever assembly. Note its position carefully so it can be re-installed correctly.
- 4) Remove the screws holding the limit switch to the bracket.
- 5) Remove the limit cover and disconnect the wiring. Note the color coding or tag the wires so they can be reconnected correctly. Loosen the cord fitting and remove the cord from the limit switch.

### **c. Weight Operated Upper Limit Switch**

- 1) Disconnect all power from the hoist.
- 2) Remove the clamping screws holding operating weight around the wire rope and remove the weight.
- 3) Remove bolts holding the limit switch bracket to the hoist and remove the limit switch assembly.
- 4) Loosen the clamping screw holding the hub on the limit switch shaft and remove the hub and lever assembly. Note its position carefully so it can be re-installed correctly.
- 5) Remove the screws holding the limit switch to the bracket.
- 6) Remove the limit cover and disconnect the wiring. Note the color coding or tag the wires so they can be reconnected correctly. Loosen the cord fitting and remove the cord from the limit switch.

## **7. REMOVE CONTROLS OR CONTROL BOX.**

- a. Remove all power from the hoist.
- b. Disconnect and tag all wires coming into the control box.
- c. Remove nuts, bolts and lockwashers holding control panel in the box.
- d. Remove control panel.
- e. Disconnect all flex conduit, limit switch cord, push-button cord and power leads from control box.
- f. Remove nuts and lockwashers holding control box mounting brackets to suspension frame.

## **8. REMOVE LOAD BRAKE ASSEMBLY.**

- a. Follow procedures in 1 and 2 for removing motor brake.
- b. Remove drain plug at the bottom of gearcase cover and drain the oil into suitable container. **DO NOT REMOVE PAWL STOP PLUG AT THIS TIME.**
- c. Remove nuts, bolts, and lockwashers from the gear case - gear case cover flange.
- d. Pry gearcase cover away from gear case.
- e. Lift out intermediate gear and slow speed pinion shaft.

**When Replacement Parts Are Needed, Order Only YALE® Factory Engineered Parts**

**PARTS AND INSTRUCTION MANUAL - EW SERIES**

**REVISED SEPTEMBER 1996**

**25**



## **PREVENTIVE MAINTENANCE SCHEDULE (CONT'D)**

- f. Cover the ratchet pawl with a rag to prevent losing the retainers which are spring loaded.
- g. Remove pawl stop and/or spring assembly.
- h. Rotate the load brake assembly until the pawl clears the load brake and the retainers pop out of the pawl.
- i. Remove the retainers and spring.
- j. Remove pawl pin and pawl. (Note that the D chassis has a cotter pin through the pawl and pin. It will be necessary to remove this cotter pin first.)
- k. Lift the load brake assembly out of the gear case cover.
- l. See Section 1340 for load brake disassembly instructions.

### **Reassembly (For all chassis and duty service except EEW X & FEW)**

The assembly sequence is basically the reverse of the disassembly sequence previously described. The following special instructions should be observed during reassembly.

1. Inspect the drum support bearing in the end of the hoist drum. Replace if damaged.

Be sure the splines in the drum are free of prime paint or other material which would interfere with installation. Lubricate these splines before assembly to prevent wear.

The hoist drum must be centered between the large bores in the suspension frame side plates. (Suspend the drum in a sling or support it on blocks.)

2. The motor adapter (with hoist motor removed) must be installed BEFORE the gear case assembly. Once installed the motor adapter supports and centers one end of the hoist drum.
3. Before gear case is assembled, all internal parts should be inspected for damage or excessive wear. Replace parts as required.
4. Inspect the universal joints on the drive shaft. Replace if damaged. Install the drive shaft assembly on the gear case pinion shaft.

Pilot the drive shaft assembly through the suspension frame bore and drum shaft splines. Before the gear case assembly is too close to the suspension frame, the loose end of the drive shaft must be lifted to go into the motor adapter bore (a length of small diameter pipe can be used for this.)

5. Inspect the motor shaft spline for nicks or other damage which would interfere with assembly into drive shaft yoke. Correct damage if necessary.

When piloting the motor onto the motor adapter, rotating the gearcase pinion (where the motor brake mounts) can help to line up the splines.

6. Be sure the motor brake is properly adjusted before it is installed on the gear case. See Section 1351.

**When Replacement Parts Are Needed, Order Only YALE® Factory Engineered Parts**

PARTS AND INSTRUCTION MANUAL - EW SERIES  
REVISED SEPTEMBER 1996



## **PREVENTIVE MAINTENANCE SCHEDULE (CONT'D)**

### **Disassembly of Hoist EEW X & FEW**

 **Caution** BEFORE DOING MAINTENANCE WORK ON THIS HOIST, READ THE FOLLOWING INSTRUCTIONS THOROUGHLY. REFER TO THE REPLACEMENT PARTS SECTION FOR PARTS IDENTIFICATION.

To completely disassemble the hoist, follow the disassembly procedures in the order listed.

To disassemble any one specific part of the hoist, follow the instructions for that specific section.

#### **1. TO REMOVE WIRE ROPE AND BOTTOM BLOCK:**

Operate push button pendant in lowering direction until lower limit switch stops hoist motor. Turn off power feed line to hoist. Remove screws from cover of traveling nut or geared type limit switch. Back cam or traveling nut away from switch that has made contact. Apply power to hoist. Operate push button in down mode to the point where no wraps of wire rope remain on hoist drum. Remove rope socket or sockets from hoist drum. Remove anchor pin from suspension frame if hoist has single reeving drum.

 **Caution** BEFORE CONTINUING WITH THE DISASSEMBLY PROCEDURES, CUT OFF ALL POWER TO THE HOIST BY DISCONNECTING THE POWER FEED LINE. REMOVE YOKE(S) AND/OR IDLER SHEAVE PIN(S) TO FREE WIRE ROPE, SHEAVE(S) AND BOTTOM BLOCK FROM HOIST.

 **Caution** NEVER DISASSEMBLE THE HOIST IN DIRTY SURROUNDINGS, NOR ALLOW DIRT, GRIT OR ANY OTHER FOREIGN MATERIAL TO GET ON THE WORKING AREAS OF THESE PARTS.

#### **2. TO DRAIN OIL FROM HOIST:**

Remove the drain plug from bottom of gearcase. See lubrication chart Page 17 when replacing oil in gearcase.

#### **3. TO REMOVE THE MOTOR BRAKE ASSEMBLY (SOLENOID ACTUATED):**

- a. Turn brake release knob counter clockwise until it can be completely removed. On 105 ft. lb. Brakes, remove two slotted screws from cover. On 125 ft. lb., Brake and larger, remove six 5/16 inch allen head screws. Brake cover can now be removed.

 **Caution** BRAKE COVER MAY BE HEAVY AND SHOULD BE SUPPORTED DURING REMOVAL.

- b. To prevent brake from losing adjustment, pull solenoid plunger to seated position and set brake release.

**When Replacement Parts Are Needed, Order Only YALE® Factory Engineered Parts**

PARTS AND INSTRUCTION MANUAL - EW SERIES  
REVISED SEPTEMBER 1996



## **PREVENTIVE MAINTENANCE SCHEDULE (CONT'D)**

- c. Remove two coil wires.
- d. Remove four 7/16 inch hex head machine screws at outside edge of support plate and remove support plate.
- e. Pressure plate, friction plate, and brake disc can be removed by pulling outward.
- f. Remove brake hub or drive block by turning allen set screw counter clockwise.
- g. Remove remaining four allen head screws. Motor brake is now disassembled.

### **4. TO REMOVE BRAKE ADAPTER:**

Remove three hex head bolts.

### **5. TO REMOVE COVER PLATES FROM GEARBOX:**

Remove eighteen hex head screws from each cover to be removed.

### **6. TO REMOVE HOIST MOTOR:**

Disconnect all motor leads from terminal blocks. Remove conduit nut on outside of control box. Pull wires through the conduit fitting. Using lifting eye on motor, prepare to support weight of motor. Remove four 1-1/8 inch hex head bolts, and pull motor outward.

### **7. TO REMOVE GEARBOX FROM SUSPENSION FRAME:**

Prepare to support weight of wire rope drum and gear box. Remove three 1 inch hex head bolts. Pull outward on gearbox until drive shaft is out of hoist.

**NOTE:** *To reassemble gearbox and drive shaft, drive shaft must be supported and aligned with motor adapter and motor shaft hole.*

### **8. TO REMOVE DRIVE SHAFT:**

Unscrew four 5/16 inch hex head bolts from spider and bearing assembly on gearcase end, and unscrew 9/16 inch hex head bolts from end of driving pinion.

### **9. TO DISASSEMBLE GEARCASE:**

- a. Remove eight 1/4 inch hex head screws from the output shaft bearing cover and retainer.
- b. Remove large retaining ring from the smaller end of output shaft which is inside the gearcase. This will allow the output shaft, driving pinion and third reduction gear to be removed from gearcase.
- c. Remove traveling nut or geared type limit switch by removing three 5/16 inch hex head screws. Switch can now be lifted off.

**When Replacement Parts Are Needed, Order Only YALE® Factory Engineered Parts**

PARTS AND INSTRUCTION MANUAL - EW SERIES  
REVISED SEPTEMBER 1996



## **PREVENTIVE MAINTENANCE SCHEDULE (CONT'D)**

- d. Remove third reduction pinion and second reduction gear. This is done by removing six 1/4 inch hex head screws from third reduction pinion, bearing, and retainer cover. Cover, bearings, pinion, gear and spacer can now be removed. See gear train illustration in Parts Section 1340 of this manual.
- e. Remove sprag clutch. This can be done by removing six 1/2 inch hex head bolts from end of sprag clutch inner race which is outside the gearcase. Inner race, gear and spacer can now be removed by applying pressure to the smaller end of inner race inside the gearcase.
- f. Remove load brake assembly, first reduction gear and second reduction pinion. This can be done by removing 1/4 inch hex screws from plate outside gearcase. This will free bearing retainer cover plate. To remove pinion, rotate high speed gear to the left, holding pinion. This will push the pinion out of load brake assembly. The pinion may now be pulled the rest of the way out of load brake. Bearings, discs, load brake gears and high speed gears can now be removed from gearcase.

**NOTE:** *To remove bearing and seal from output shaft, remove retainer snap ring.*

### 10. TO DISASSEMBLE MOTOR ADAPTER FROM SUSPENSION FRAME:

Prepare to support weight of wire rope drum and motor adapter. Remove three 1 inch hex head bolts and nuts. This will allow adapter to be pulled away from frame and drum.

### 11. TO REMOVE WIRE ROPE DRUM FROM HOIST:

Motor adapter and gearcase must be removed from the suspension frame before drum can be removed. (See steps 7 and 10.)



#### **Caution**

**DRUM IS HEAVY AND MUST BE SUSPENDED BEFORE REMOVING MOTOR ADAPTER AND GEARCASE.**

### 12. TO REMOVE CONTROLS OR CONTROL BOX:

Remove all power from hoist. Disconnect and tag all wires coming into control box. Remove nuts, bolts and lockwashers holding panel in box. Remove control panel. Disconnect all flexible conduit, limit switch, cord, push button cord, and power leads from control box. Remove nuts, bolts and lockwashers holding control box to the hoist, and remove control box.

### 13. TO DISASSEMBLE BOTTOM BLOCK:

Use normal disassembly procedures and refer to applicable bottom block parts pages to remove hook, sheaves, etc. from bottom block.

**When Replacement Parts Are Needed, Order Only YALE® Factory Engineered Parts**

**PARTS AND INSTRUCTION MANUAL - EW SERIES**

**REVISED SEPTEMBER 1996**

**29**



## PREVENTIVE MAINTENANCE SCHEDULE (CONT'D)

### Assembly of Hoist

#### 1. TO REASSEMBLE HOIST EEW X & FEW:

Reverse preceding disassembly procedures. Make sure all parts are properly adjusted and lubricated per applicable instructions. Replace bearings and gaskets if they have been damaged. (See chart on Page 17 for type of oil when refilling.)

**NOTE:** *To assemble load brake, the high speed gear, inner bearing race and spacer brake must be aligned. If possible, the inboard side of the gearcase should be laid flat on a table during reassembly. This will make it easier to align holes. If gear box is standing upright, the housing must be held in position to assemble the load brake.*



#### Caution

**IF THE LOAD BRAKE IS DISASSEMBLED WITH THE GEARBOX ON THE HOIST, ROTATING OF DRUM MUST BE PREVENTED.**

**NOTE:** *After assembly, the hoist must be function tested in accordance with instructions on Page 15 of this manual.*

### Troubleshooting (For all chassis and duty service except EEW X & FEW)

#### UNIT NOISY

Possible Cause	Remedy
1. Nicked Gears	1. Examine teeth for nicks and burrs. Remove with honing stone, replace if teeth are severely damaged.
2. No oil.	2. Fill to oil level hole.
3. Defective bearing.	3. Replace.

**When Replacement Parts Are Needed, Order Only YALE® Factory Engineered Parts**

PARTS AND INSTRUCTION MANUAL - EW SERIES  
REVISED SEPTEMBER 1996





## PREVENTIVE MAINTENANCE SCHEDULE (CONT'D)

### OIL SEEPAGE

Possible Cause	Remedy
1. Fill plug loose.	1. Tighten.
2. Gearcase cover loose.	2. Tighten screws.
3. No hole in vent plug.	3. Replace with vent plug.
4. Defective seals.	4. Check lips of seal for worn or rough edges. Replace as necessary.

### LOAD DRIFTS OR DROPS

Possible Cause	Remedy
1. Motor brake slipping.	1. Adjust brake. Check for oil on brake discs.
2. Motor brake not closing.	2. Adjust for proper clearance. (See Section 1351.) If not effective, check load brake per Item 4, Monthly Inspection, Page 13.
3. Retainer or retainer spring missing or broken.	3. Replace.
4. Load brake discs worn or glazed.	4. If standard duty brake discs are not worn to less than 1/8 inch thick, rough brake disc surface (and surfaces that contact discs) with coarse emery cloth. Wash thoroughly and reassemble. If not effective or if discs are less than 1/8 inch thick, replace ratchet and disc assembly.
5. Load brake pawl not operating.	5. Check for tight fitting pawl or retainer tight in pawl. Replace if necessary. (See Section 1340)
6. Load brake not closing.	6. Check for burrs on thread of intermediate pinion or high speed gear. Hone or replace. Mating parts must rotate easily.
7. Ratchet installed backwards.	7. Turn around.

When Replacement Parts Are Needed, Order Only YALE® Factory Engineered Parts

PARTS AND INSTRUCTION MANUAL - EW SERIES

REVISED SEPTEMBER 1996

31



## PREVENTIVE MAINTENANCE SCHEDULE (CONT'D)

### BRAKE COIL BURNED OUT

 **Caution** ALWAYS DISCONNECT POWER CIRCUIT BEFORE WORKING ON ELECTRICAL COMPONENTS.

Possible Cause	Remedy
1. Wrong coil.	1. Replace with proper voltage coil.
2. Motor brake too tight.	2. Adjust brake. (See Section 1351)

### HOIST DOES NOT OPERATE

Possible Cause	Remedy
1. Blown or loose fuse.	1. Replace or tighten fuse.
2. Tripped breaker.	2. Reset breaker.
3. Loose terminal screws.	3. Check and tighten all loose screws.
4. Low voltage.	4. Check voltage at line side of reversing switch.
5. Low voltage or no voltage to push button circuit.	5. Check voltage at output side of transformer. Wrong voltage tap may have been selected. For example: 460 volt tap used when line voltage is 230 volt. Check control circuit fuse.
6. Defective push button.	6. Check contact points at push button to see if points touch. If not, replace.
7. Defective push button cord. (Wire may be pinched, broken or bare.)	7. Check for lack of continuity or short to ground.
8. Burned coil in reversing contactor.	8. Replace bearings.
9. Burned contact tips.	9. Replace tips.
10. Motor brake coil burned.	10. Replace. Check to make sure coil is proper coil for voltage applied.

When Replacement Parts Are Needed, Order Only YALE® Factory Engineered Parts

PARTS AND INSTRUCTION MANUAL - EW SERIES  
REVISED SEPTEMBER 1996



## PREVENTIVE MAINTENANCE SCHEDULE (CONT'D)

11. Defective stator.	11. Rewind stator.
12. Rotor loose on shaft.	12. Reposition rotor and tack weld in place.
13. Motor runs but drum does not turn.	13. Splines stripped in drum or drive shaft yokes. Replace defective components.

### MOTOR OVERHEATS, EXCESSIVE AMPERAGE DRAW

Possible Cause	Remedy
1. Defective stator.	1. Replace or rewind stator.
2. Worn motor bearings.	2. Replace.
3. Bent rotor shaft.	3. Replace rotor shaft.
4. Rotor dragging in stator.	4. Tighten motor bolts. Check for foreign matter between rotor and stator. Check for worn motor bearings.
5. Stator loose in frame.	5. Rewind stator if necessary. Reposition and anchor in accordance with motor manufacturers instructions.
6. Low voltage.	6. Check with local utility company and/or increase wire size.

### MOTOR NOISY

Possible Cause	Remedy
1. Motor bolts loose.	1. Tighten.
2. Rotor dragging in stator.	2. Check for bent rotor shaft or worn bearings. Replace defective parts.
3. Motor bearings loose.	3. Replace bearings.

When Replacement Parts Are Needed, Order Only YALE® Factory Engineered Parts

PARTS AND INSTRUCTION MANUAL - EW SERIES  
REVISED SEPTEMBER 1996



## **PREVENTIVE MAINTENANCE SCHEDULE (CONT'D)**

### **TRANSFORMER OVERHEATS OR BURNS OUT**

<b>Possible Cause</b>	<b>Remedy</b>
1. Wrong tap used on primary side.	1. Replace transformer if necessary. Primary tap must match line voltage.
2. Shorted transformer.	2. Replace.
3. Shorted control circuit.	3. Correct short.

### **REVERSING CONTACTOR COIL BURNED OUT**

<b>Possible Cause</b>	<b>Remedy</b>
1. Wrong coil used.	1. Replace coil. Be sure coil conforms to voltage of circuit it is used on.
2. Jammed plunger.	2. Disassemble and clean. Do not lubricate plunger or coil.
3. Shorted coil	3. Replace.

### **HOIST SHOCKS OPERATOR**

<b>Possible Cause</b>	<b>Remedy</b>
1. Hoist not grounded.	1. Ground hoist.
2. Power leads or control wires shorted to hoist frame.	2. Repair or replace.
3. Grounded motor.	3. Replace.
4. Slight electrical leakage from any of the electrical components on hoist.	4. Make sure hoist is properly grounded.

**When Replacement Parts Are Needed, Order Only YALE® Factory Engineered Parts**

**PARTS AND INSTRUCTION MANUAL - EW SERIES**

**REVISED SEPTEMBER 1996**



## **PREVENTIVE MAINTENANCE SCHEDULE (CONT'D)**

### **Troubleshooting (For EEW X & FEW)**

#### **UNIT NOISY**

Possible Cause	Remedy
1. Nicked gears.	1. Examine teeth for nicks and burrs. Remove with honing stone, replace if teeth are severely damaged.
2. No oil.	2. Fill to oil level hole.
3. Defective bearing.	3. Replace.
4. Slow speed gear upside down.	4. Turn over. Chamfer on splined hole must face gear case.

#### **OIL SEEPAGE**

Possible Cause	Remedy
1. Fill plug loose.	1. Tighten.
2. Gearcase cover loose.	2. Tighten screws.
3. No hole in vent plug.	3. Replace with vent plug.
4. Defective seals.	4. Check lips of seal for worn or rough edges. Replace as necessary.

#### **LOAD DRIFTS OR DROPS**

Possible Cause	Remedy
1. Load brake discs worn or glazed.	1. If standard duty brake discs are not worn to less than 1/8 inch thick, rough brake disc surface (and surfaces that contact discs) with coarse emery cloth. Wash thoroughly and reassemble. If not effective or if discs are less than 1/8 inch thick, replace gear and disc assembly.

**When Replacement Parts Are Needed, Order Only YALE® Factory Engineered Parts**

**PARTS AND INSTRUCTION MANUAL - EW SERIES  
REVISED SEPTEMBER 1995**



## PREVENTIVE MAINTENANCE SCHEDULE (CONT'D)

2. One-way (Sprag) clutch not operating.	2. Repair or replace clutch. (See Section 1340.)
3. Load brake not closing.	3. Check for burrs on thread of intermediate pinion or high speed gear. Hone or replace. Mating parts must thread easily.
4. Motor brake slipping.	4. Replace brake discs. Check for oil on discs.

### BRAKE COIL BURNED OUT

 **Caution** ALWAYS DISCONNECT POWER CIRCUIT BEFORE WORKING ON ELECTRICAL COMPONENTS.

Possible Cause	Remedy
1. Wrong coil.	1. Replace with proper voltage coil.

Two speed motors require line voltage brake coil.

### HOIST DOES NOT OPERATE

Possible Cause	Remedy
1. Blown or loose fuse.	1. Replace or tighten fuse.
2. Tripped breaker.	2. Reset breaker.
3. Loose terminal screws.	3. Check and tighten all loose screws.
4. Low voltage.	4. Check voltage at line side of reversing switch.
5. Low voltage or no voltage to push button circuit.	5. Check voltage at output side of transformer. Wrong voltage tap may have been selected. For example: 460 volt tap used when line voltage is 230 volt. Check control circuit fuse.
6. Defective push button.	6. Check contact points at push button to see if points touch. If not, replace.

When Replacement Parts Are Needed, Order Only YALE® Factory Engineered Parts

PARTS AND INSTRUCTION MANUAL - EW SERIES  
REVISED SEPTEMBER 1996



## PREVENTIVE MAINTENANCE SCHEDULE (CONT'D)

7. Defective push button cord.	7. Check for lack of continuity or short to ground.
8. Burned coil in reversing contactor.	8. Replace.
9. Reversing contactor plunger jammed in switch.	9. Check for burned coil. Disassemble and replace defective components. Do not lubricate.
10. Burned contact tips.	10. Replace tips.
11. Motor brake coil burned.	11. Replace. Check to make sure coil is proper coil for voltage applied.
12. Defective stator.	12. Rewind stator.
13. Rotor loose on shaft.	13. Reposition rotor and tack weld in place.

### MOTOR OVERHEATS, EXCESSIVE AMPERAGE DRAW

Possible Cause	Remedy
1. Defective stator.	1. Replace or rewind stator.
2. Worn motor bearings.	2. Replace.
3. Bent rotor shaft.	3. Replace rotor shaft.
4. Rotor dragging in stator.	4. Tighten motor bolts. Check for foreign matter between rotor and stator. Check for worn motor bearings.
5. Stator loose in frame.	5. Rewind stator if necessary. Reposition and anchor in accordance with motor manufacturers instructions.
6. Low voltage.	6. Check with local utility company and/or increase wire size.

**When Replacement Parts Are Needed, Order Only YALE® Factory Engineered Parts**

PARTS AND INSTRUCTION MANUAL - EW SERIES

REVISED SEPTEMBER 1996

37



## **PREVENTIVE MAINTENANCE SCHEDULE (CONT'D)**

### **MOTOR IS ERRATIC, STOP-START, ETC.**

<b>Possible Cause</b>	<b>Remedy</b>
1. Faulty limit switch.	1. Disassemble limit switch. Grit or chips of plastic may be between contact points. Clean thoroughly with carbon tetrachloride, cleaning fluid or lighter fluid. Reassemble. Replace switch if this fails to correct trouble or if switch is cracked. Check for proper adjustment.

### **HOIST OPERATES IN WRONG DIRECTION**

<b>Possible Cause</b>	<b>Remedy</b>
1. Motor out of phase with power source.	1. Interchange any two line wires for 3-phase.

### **HOIST OPERATES IN ONE DIRECTION**

<b>Possible Cause</b>	<b>Remedy</b>
1. Push button circuit wired wrong.	1. Check wiring and reposition wires.
2. Contact tips burned.	2. Replace.
3. Loose screws or wires.	3. Tighten.
4. Internal motor connection or broken.	4. Check for continuity. Repair or replace motor.
5. Defective limit switch.	5. Repair or replace.

**When Replacement Parts Are Needed, Order Only YALE® Factory Engineered Parts**

**PARTS AND INSTRUCTION MANUAL - EW SERIES  
REVISED SEPTEMBER 1996**





## **PREVENTIVE MAINTENANCE SCHEDULE (CONT'D)**

### **MOTOR NOISY**

Possible Cause	Remedy
1. Motor bolts loose.	1. Tighten.
2. Rotor dragging in stator.	2. Check for bent rotor shaft or worn bearings. Replace defective parts.
3. Motor bearings loose.	3. Replace bearings.

### **TRANSFORMER OVERHEATS OR BURNS OUT**

Possible Cause	Remedy
1. Wrong tap used on primary side.	1. Replace transformer if necessary. Primary tap must match line voltage.
2. Shorted transformer.	2. Replace.
3. Shorted control circuit.	3. Correct short.

### **REVERSING CONTACTOR COIL OR BRAKE SOLENOID COIL BURNED OUT.**

Possible Cause	Remedy
1. Wrong coil used.	1. Replace coil. Be sure coil conforms to voltage of circuit it is used on.
2. Jammed plunger.	2. Disassemble and clean. Do not lubricate plunger or coil.
3. Shorted coil	3. Replace.

**When Replacement Parts Are Needed, Order Only YALE® Factory Engineered Parts**

**PARTS AND INSTRUCTION MANUAL - EW SERIES**

REVISED SEPTEMBER 1996

39



## **PREVENTIVE MAINTENANCE SCHEDULE (CONT'D)**

### **HOIST SHOCKS OPERATOR**

<b>Possible Cause</b>	<b>Remedy</b>
1. Hoist not grounded.	1. Ground hoist.
2. Power leads or control wires shorted to hoist frame.	2. Repair or replace.
3. Grounded motor.	3. Replace.
4. Slight electrical leakage from any of the electrical components on hoist.	4. Make sure hoist is properly grounded.

**When Replacement Parts Are Needed, Order Only YALE® Factory Engineered Parts**

**PARTS AND INSTRUCTION MANUAL - EW SERIES  
REVISED JULY 1996**

# Yale Hoisting Equipment

SECTION 1110

FRAME

USER INFORMATION PAGE

**REFER TO PARTS LIST IN FRONT COVER FOR COMPONENT NUMBER**

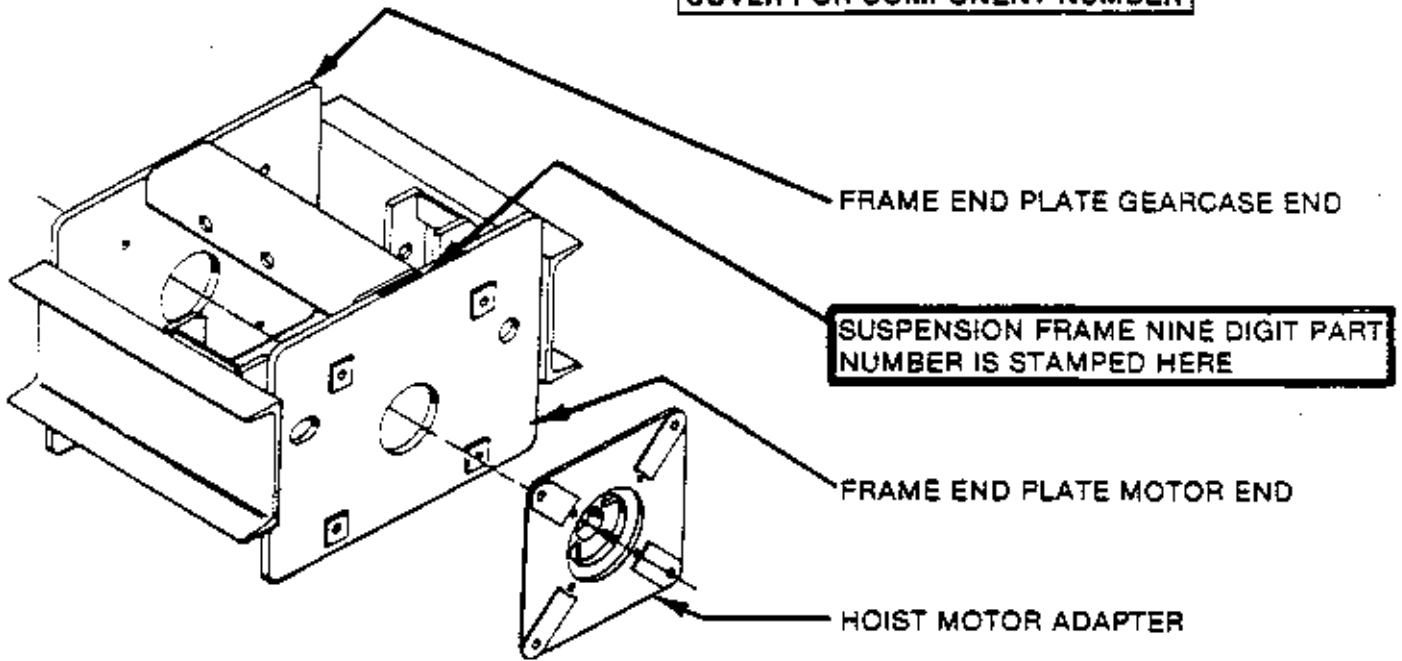

The suspension frame illustrated above may not exactly represent the actual appearance of the frame. However, it is typical.

**IMPORTANT:** WHEN ORDERING REPLACEMENT SUSPENSION FRAME USE NINE DIGIT NUMBER STAMPED ON SUSPENSION FRAME. IF NUMBER IS NOT LEGIBLE, IT IS IMPERATIVE THAT COMPLETE MODEL AND SERIAL NUMBER OF HOIST BE FURNISHED. THIS INFORMATION IS STAMPED ON HOIST NAME PLATE

FORM NO. 165-903-101

**When Replacement Parts Are Needed, Order Only Yale® Factory Engineered Parts**

JUNE 1982

EW SERIES

**SECTION 1120**

**DRUM**

**REFER TO PARTS LIST IN FRONT COVER FOR COMPONENT NUMBER**

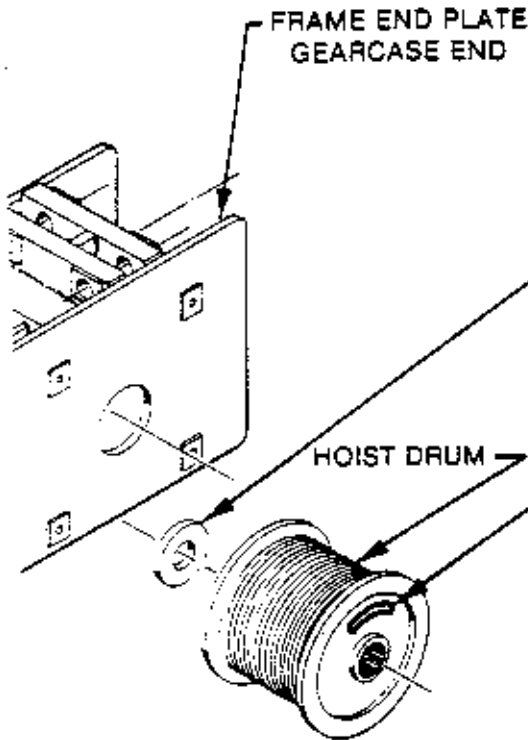

**DRUM BEARING**

PART NUMBER	CHASSIS
5025079-02	B & C
6401629-01	D & E

**HOIST DRUM NINE DIGIT PART NUMBER IS STAMPED HERE**

**ROPE RETAINER BRACKET ASM.**  
B, C, D & E CHASSIS  
ROPE SIZE 3/16 in. THRU 3/4 in.

6439342-00 ASSEMBLY INCLUDES

PART NBR.	DESCRIPTION	QTY.
6466571-00	BRACKET	1
0597115-00	3/8 - 16 - 3/4 lg.	1
0150264-00	LOCKWASHER	1

**Yale**

Capacity, tons 5

Speed, ft/min 30

Model FEW10-51CB46D2

Serial AB77867

Volts 460 Phase 3 Hz 60

Min. Circuit Ampacity \_\_\_\_\_

Max. Fuse Rating \_\_\_\_\_

Order No. W122345

**H4**

**F.T.N** Eaton Corporation Made in U.S.A.

THIS HOIST IS DESIGNED TO MEET THE REQUIREMENTS FOR USE IN SERVICE AND IS APPROVED FOR STANDING OR HEAVY DUTY APPLICATIONS UNDER THE TOTAL RUNNING TIME OF THE HOIST DOES NOT EXCEED 5% OF THE WORK PERIOD.

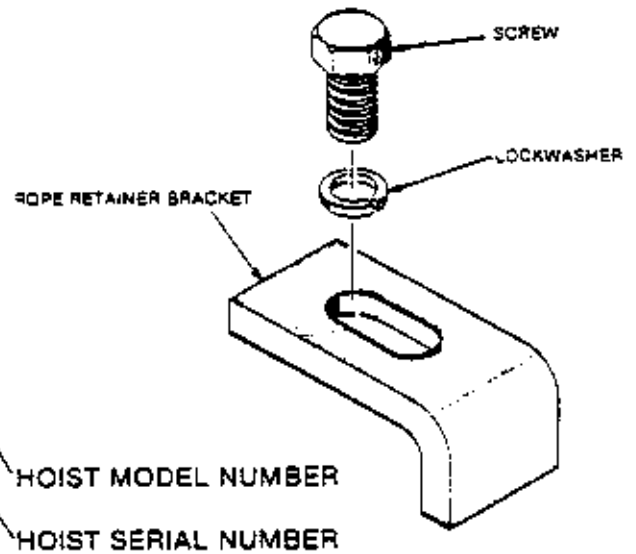

**HOIST NAME PLATE**

The nameplate illustrated above may not exactly represent the actual appearance of the hoist name plate. However, it is typical.

**IMPORTANT:** WHEN ORDERING REPLACEMENT HOIST DRUM USE NINE DIGIT NUMBER STAMPED ON HOIST DRUM. IF NUMBER IS NOT LEGIBLE, IT IS IMPERATIVE THAT COMPLETE MODEL AND SERIAL NUMBER OF HOIST BE FURNISHED. THIS INFORMATION IS STAMPED ON HOIST NAME PLATE

FORM NO. 165-903-101

**When Replacement Parts Are Needed, Order Only Yale® Factory Engineered Parts**

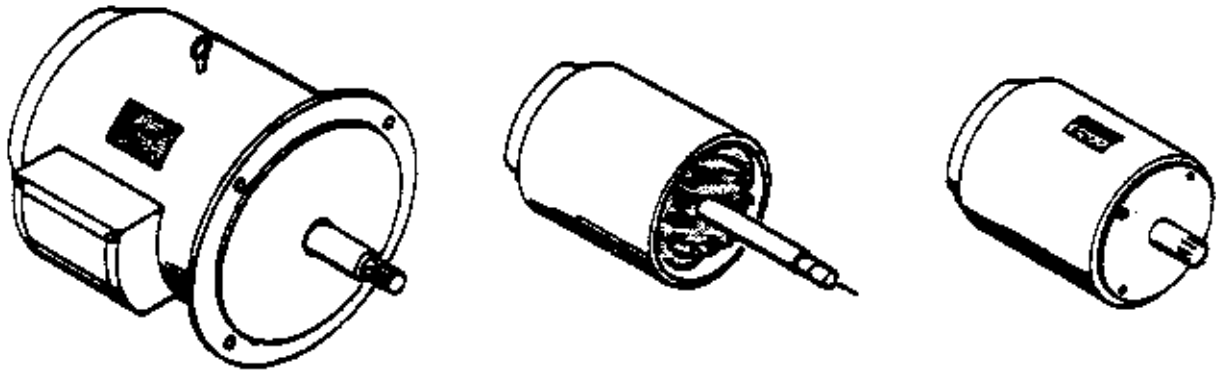
**SECTION 1210  
HOIST MOTOR**

For Part Number Of Complete Motor, Refer To Parts List In Front Cover Of Manual. Part Number May Also Be Found On Motor Nameplate.

If Individual Motor Parts Are Required, Specify Motor Part Number, Motor Model And Serial Numbers From The Motor Nameplate, Hoist Model And Serial numbers From The Hoist Nameplate, And A Complete Description Of The Items Needed.

**SECTION 1315**  
**DRIVE SHAFT**  
**&**  
**SPIDER ASM.**

**REFER TO PARTS LIST IN FRONT  
COVER FOR COMPONENT NUMBER**

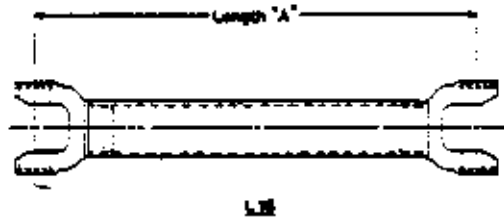

**SPIDER**



**SECTION 1340****GEARING &  
LOAD BRAKE**

# Yale Hoisting Equipment

**GEAR TRAIN AND LOAD BRAKE ASSEMBLY****OPERATION DESCRIPTION AND MAINTENANCE OF YALE LOAD BRAKE****PURPOSE**

The main purpose of the Yale "Weston Screw And Disc Type" load brake is to control the lowering speed of the hoist. The secondary purpose is to act as an auxiliary brake.

**OPERATION**

The load brake functions regardless of whether the current is on or off when lowering. When the current is off the load pulls in a counter - clockwise direction on the slow speed gear and screws the brake up tight locking all the parts of the load brake together. A pawl engages the ratchet and disc assembly holding the load stationary when the pull is in this direction. The greater the load, the more definite the locking action.

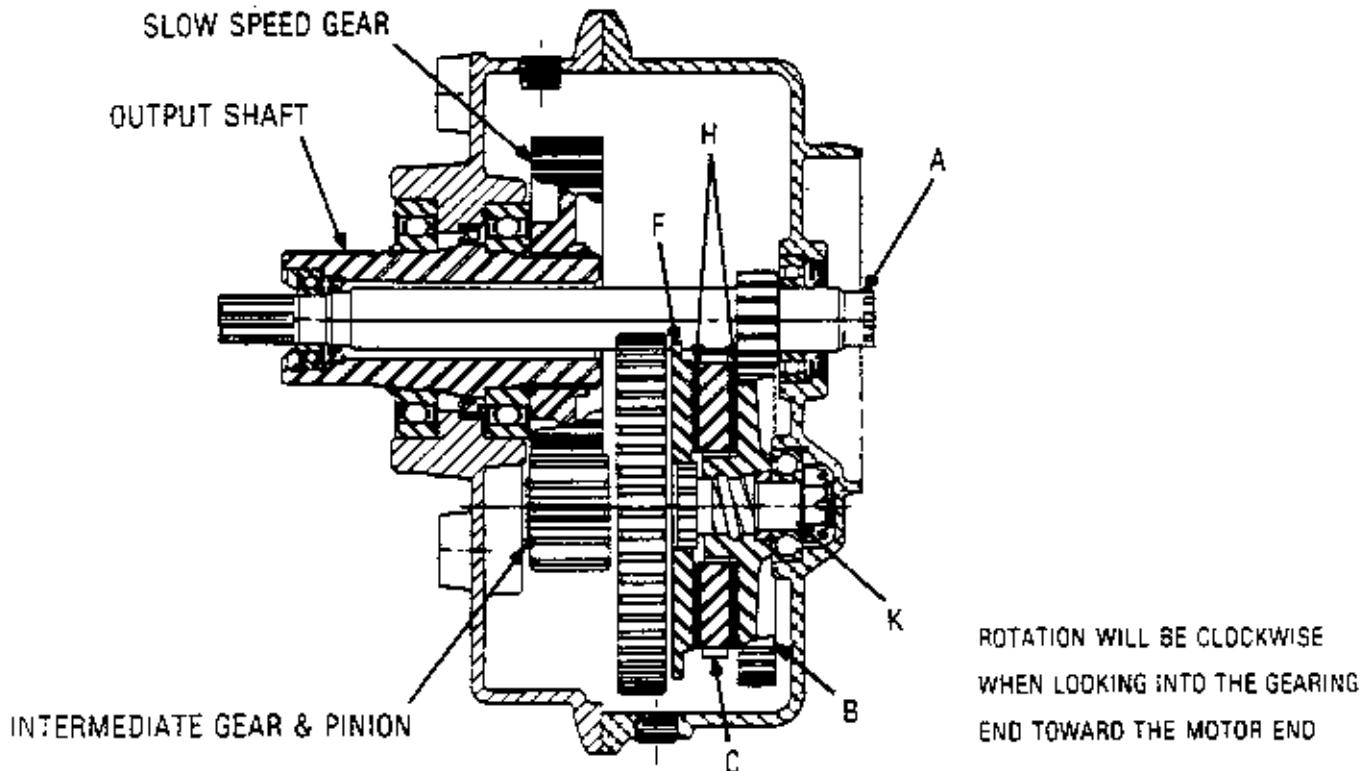

FIGURE 1

YA - 0246

When hoisting, running in the up direction, power from the motor is applied through the driving pinion A to the high speed gear B. This gear, with its threaded hub, screws clockwise and all of the brake parts become tight and move as a unit in the clockwise direction.

FORM NO. 165-904-009

**When Replacement Parts Are Needed, Order Only Yale® Factory Engineered Parts**

REV JUNE 1982

1

EW SERIES

**SECTION 1340****GEARING &  
LOAD BRAKE****GEAR TRAIN AND BRAKE ASSEMBLY  
EW SERIES**

Movement is free because the ratchet gear and disc assembly C is moving clockwise and it can rotate without the teeth engaging the pawl D. In this direction of rotation, the pawl is held away from the ratchet by a spring loaded friction button E which is part of the pawl assembly and presses outward simultaneously on the reaction disc F and high speed gear B. As the load brake rotates in this direction it tends to drag the spring loaded button with it causing the pawl to ride over the ratchet teeth ready to catch and hold the pawl the instant the load starts to lower. The load brake is completely locked when operating in this direction and there is no loss of power due to friction in the load brake.

When lowering, the driving pinion reverses the direction of the high speed gear, turning it counter-clockwise. This unscrews the high speed gear and loosens the load brake. At the same time the load is pulling through the gear train in a clockwise direction on the intermediate pinion K trying to tighten the brake. This interaction is constantly going on when the hoist is lowering. In a smoothly operating load brake the motor uses about one-third to one-half of its rated horsepower to drive the load down by keeping a satisfactory adjustment on the brake between the open and closed position. This operation must be just fast enough to keep the pull of the load from getting ahead and closing the brake. The load is always under control as it is the action of the motor which lowers it while the weight of the load always works to close the brake.

In this lowering operation friction slows the load as the brake is just slightly open. The ratchet and disc assembly is held stationary by the ratchet pawl, while high speed gear revolves. The brake discs H are bonded to the ratchet to form the ratchet and disc assembly C. The friction of the high speed gear B and reaction disc F against the stationary ratchet and disc assembly, with the aid of oil lubrication produces a positive braking action permitting easy and gradual lowering.

The instant the down button is released, the high speed gear becomes stationary because the motor brake holds the driving pinion stationary, and the pull of the load closes the brake as it is held by the ratchet pawl.

When the hoist lowers without a load, the high speed gear opens the brake and drives the hook down directly through the gear train. Only the friction of the normally operating gears interferes with free action and therefore such lowering is usually slightly faster than lowering with a load.

**LOAD BRAKE MAINTENANCE**

The operation of the load brake provides automatic adjustment for wear of the brake disc. The only maintenance normally necessary is infrequent replacement of the ratchet and disc assembly. To check operation of the load brake, see instructions for daily, monthly and annual inspection in Preventive Maintenance Schedule (Section B).

FORM NO. 165-904-009

**When Replacement Parts Are Needed, Order Only Yale® Factory Engineered Parts**

EW SERIES

2

REV. JUNE 1982



# Yale Hoisting Equipment

## SECTION 1340 GEARING & LOAD BRAKE

### GEAR TRAIN AND LOAD BRAKE ASSEMBLY

### OPERATION DESCRIPTION AND MAINTENANCE OF YALE LOAD BRAKE

### LOAD BRAKE REMOVAL

Follow steps 1, 2 and 8 of Disassembly Instructions in Section B (Maintenance).

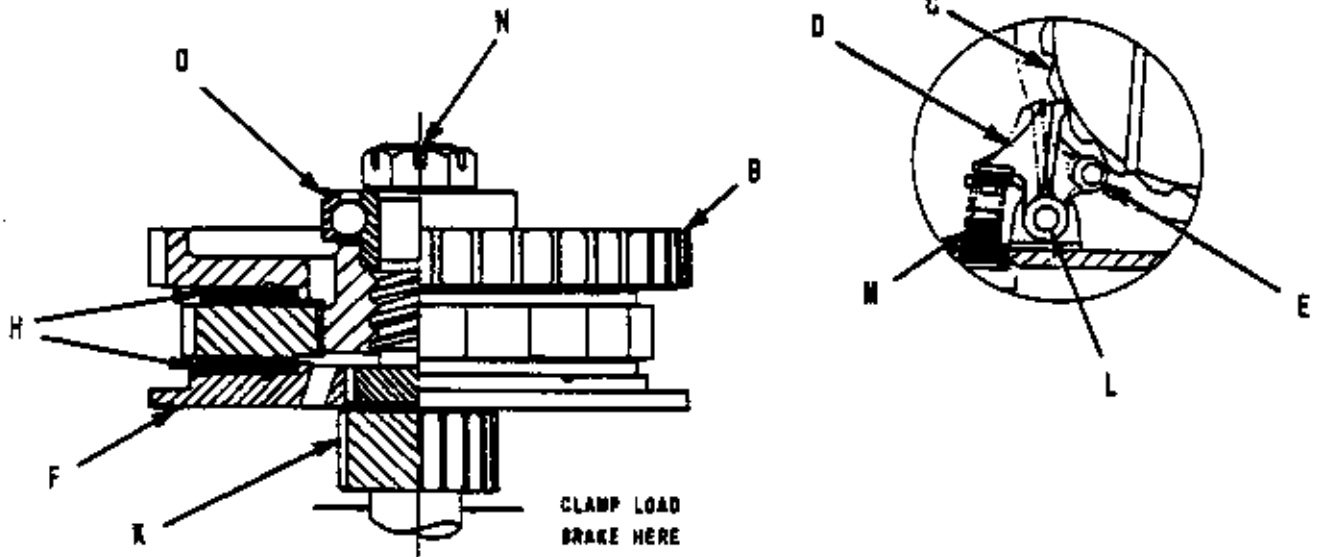

FIGURE 2

YA-0247

04-009  
FORM NO. 165-904-009

**When Replacement Parts Are Needed, Order Only Yale® Factory Engineered Parts**

REV. JUNE 1982

EW SERIES

**SECTION 1340****GEARING &  
LOAD BRAKE****LOAD BRAKE DISASSEMBLY**

Place the load brake in a vise and tighten jaws over the shoulder below the intermediate pinon K.

Load brake is now ready for disassembly in the following manner.

1. Remove the cotter pin from the castellated nut and remove nut.
2. Remove high speed gear B.
3. Take off ratchet and disc assembly noting the direction the ratchet teeth are facing.

Before replacing the ratchet and disc assembly and the high speed gear, make sure all dirt or foreign material is cleaned off.

**LOAD BRAKE RE - ASSEMBLY**

1. Place the ratchet and disc assembly on the shaft, then thread the gear on until it is tight.
2. Place spacer and bearing on the end of the shaft and press it down into the ground recess in the gear.
3. Tighten the castellated nut down on the bearing. Then back the nut off slowly until the first castellation lines up with the hole drilled in the shaft and slip cotter pin through this hole. Open the brake and check the adjustment by turning the ratchet gear and disc assembly. If properly adjusted it should turn freely. Bend the cotter pin around nut and cut off excess.

**LOAD BRAKE INSTALLATION**

1. Insert the load brake in the gearcase cover.
2. Install pawl and pawl pin. (Note that the D chassis has a cotter pin which must be inserted through the pawl and pin.)
3. Take one button, then the spring, then the second button and slide them through the pawl in that order holding a finger over the bottom of the pawl so the buttons will not slide out. Press hard on buttons, compressing the spring enough to slide the complete pawl between ratchet disc and high speed gear.
4. Replace the pawl stop and/or spring assembly.

**LUBRICATION**

See Section B.

04-009

FORM NO. 185-904-008

**When Replacement Parts Are Needed, Order Only Yale® Factory Engineered Parts**

EW SERIES

4

REV. JUNE 1982

# Yale Hoisting Equipment

FEW - & FAW -

**IMPORTANT**  
SELECT COMPONENT ASSEMBLY  
NUMBER FROM PARTS LIST IN FRONT  
COVER BEFORE SELECTING  
REPLACEMENT ITEM NUMBER

GEARING &  
LOAD BRAKE

6407937-01  
THRU  
6407937-20  
&  
6427062-01  
THRU  
6427062-04

TABLE 1

**GEARCASE ASM. STANDARD EW**

TWO DIGIT CODE	ASM. NO.	GEAR RATIO
05	6407937-05	73.1 : 1
06	6407937-06	96.6 : 1
07	6407937-07	117.3 : 1
08	6407937-08	159.7 : 1
10	6407937-10	63.0 : 1

**GEARCASE ASM. EW W/O LOAD BRAKE**

TWO DIGIT CODE	ASM. NO.	GEAR RATIO
01	6407937-01	73.1 : 1
02	6407937-02	96.6 : 1
03	6407937-03	117.3 : 1
04	6407937-04	159.1 : 1
09	6407937-09	63.0 : 1

**GEARCASE ASM. EW HEAVY DUTY**

TWO DIGIT CODE	ASM. NO.	GEAR RATIO
11	6407937-11	63.0 : 1
12	6407937-12	73.1 : 1
13	6407937-13	96.6 : 1
14	6407937-14	117.3 : 1
15	6407937-15	159.7 : 1

**GEARCASE EW EXP. PROOF**

TWO DIGIT CODE	ASM. NO.	GEAR RATIO
01	6427062-01	73.1 : 1
02	6427062-02	96.6 : 1
03	6427062-03	117.3 : 1
04	6427062-04	159.1 : 1

**GEARCASE ASM. STANDARD AW**

TWO DIGIT CODE	ASM. NO.	GEAR RATIO
16	6407937-16	63.0 : 1
17	6407937-17	73.1 : 1
18	6407937-18	96.6 : 1
19	6407937-19	117.3 : 1
20	6407937-20	159.7 : 1

TABLE 2

**MOTOR BRAKE ASSEMBLY**

Mtr. Brake Cap.	Brake Adapter	Mtr. Brake Cap.	Brake Adapter	Mtr. Brake Cap.	Brake Adapter
105 Ft. Lb.	□ 6420066-00	125 Ft. Lb.	□ 6419746-00	175 Ft. Lb.	□ 6419746-00

FORM NO. 165-904-308

**When Replacement Parts Are Needed, Order Only Yale® Factory Engineered Parts**

REV. JANUARY 1983

EW 4/15/83-25

# Yale® Hoists

## SECTION 1340

### Gearing & Load Brake

FEW & FAW

**IMPORTANT**  
 SELECT COMPONENT NUMBER AND PART  
 NUMBER FROM PARTS LIST IN FRONT OF  
 MANUAL FOR REPLACEMENT PARTS

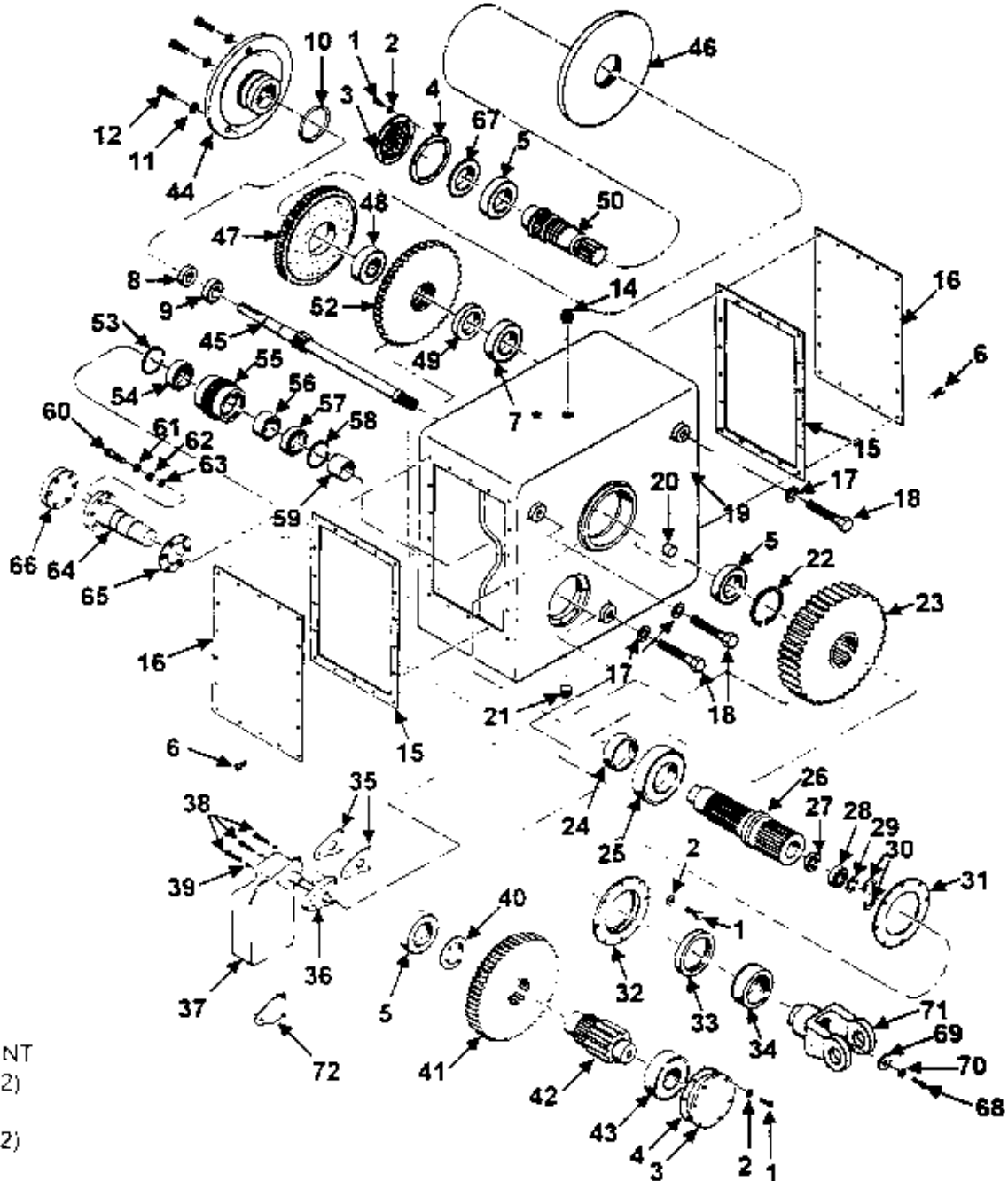

NOTE:  
 FILL THRU VENT  
 PLUG (ITEM 42)  
 TO OIL LEVEL  
 PLUG (ITEM 32)

When Replacement Parts Are Needed, Order Only Yale® Factory Engineered Parts

Rev. January, 1995

EW/AW Series

GEAR TRAIN AND BRAKE ASSEMBLY

ITEM	PART NO.	DESCRIPTION	QTY.
1	2031426-00	SCREW	20
2	0150288-00	LOCKWASHER	20
3	6437524-00	BEARING RETAINER PLATE	2
4	6437554-00	GASKET	2
5	0164933-00	BEARING	3
6	6441518-00	SCREW	36
7	6442478-00	BEARING	1
8	6441468-00	SEAL	1
9	0151258-00	BEARING	1
10	0664140-00	"O" RING	1
11	0150326-00	LOCKWASHER	3
12	7202239-04	SCREW	3
13	5018849-02	OIL LEVEL PLUG (NOT SHOWN)	2
14	6442538-00	VENT PLUG	2
15	6439564-00	GASKET	1
16	6437594-00	GEARCASE COVER	2
17	0150297-00	LOCKWASHER	3
18	2031607-00	HEX SCREW	3
19	6407967-00	GEARCASE	1
20	6445118-00	TORQUE PIN	1
21	0533540-00	PLUG DRAIN	1
22	6442488-00	RETAINING RING	1
23	6437434-00	GEAR	1
24	6430713-00	SPACER OUTPUT SHAFT	1
25	3121482-00	BEARING	1
26	6419546-00	OUTPUT SHAFT	1
27	6401229-05	SEAL DRIVING PINION	1
28	6442468-00	BEARING DRIVING PINION	1
29	6400469-13	RETAINING RING	1
30	6446108-00	RETAINING RING	1
31	6436744-00	GASKET	1
32	6437614-00	BEARING RETAINER PLATE	1
33	6441478-00	SEAL	1
34	6431603-00	DRUM SPACER	1
35	6443558-00	GASKET	2
36	6442553-00	SPACER	1
37	SEE SECTION K	TRAVELING NUT LIMIT SWITCH	1
39	6459758-00	WASHER & SCREW	3
40	6430728-00	SPACER	1
41	6437454-00	GEAR, 2nd REDUCTION	1
42	6437444-00	SLOW SPEED PINION	1
43	6442458-00	BEARING	1
44	SEE TABLE 2	BRAKE ADAPTER	1
45	SEE TABLE 3	DRIVING PINION	1
46	SEE TABLE 3	DISC	1
47	SEE TABLE 3	LOAD BRAKE ASM.	1
48	6401699-01	ROLLER BEARING	1
49	5431053-00	SPACER	3
50	SEE TABLE 3	PINION, 2nd REDUCTION	1
51	0162415-00	WOODRUFF KEY (NOT SHOWN)	1
52	SEE TABLE 3	HIGH SPEED GEAR	1
53	5019899-03	RETAINING RING	1
54	6400889-04	BEARING	1
55	6452314-00	OUTER RACE GEAR	1
56	6442503-00	SPRAG RETAINER ASM.	1
57	6400889-05	BEARING	1
58	6400469-22	RETAINING RING	1
59	6442513-00	SPACER	3
60	3596946-00	SCREW	6
61	0150288-00	LOCKWASHER	6
62	0161100-00	WASHER	6
63	6459728-00	THREAD SEAL	6
64	6452304-00	SHAFT	1
65	6442523-00	GASKET	1
66	6442543-00	COVER PLATE (UNITS W/O LOAD BRAKE)	1
67	6449771-00	SHIM	3
68	0570482-00	SCREW	1
69	6446868-00	WASHER	1
70	0150310-00	LOCKWASHER	1
71	6497771-00	YOKE	1
72	0102953-00	COVER PLATE (W/O LIMIT SWITCH)	1
73	6451523-02	LIQUID GASKET (NOT SHOWN)	4

Note: Units Without Load Brake Do not Use Items 46, 47, 48, 49, 53, 54, 55, 56, 57, 58, 59 & 64  
 LOCTITE GASKET ELIMINATOR NO. 515 (NOT SHOWN)

-008-3 FORM NO. 165-904-008

When Replacement Parts Are Needed, Order Only Yale® Factory Engineered Parts

REV JANUARY 1983

EW / AW SERIES

6407937-01 - 20  
 6427062-01 - 04

**TABLE 3**

**SELECT COMPONENT ASSEMBLY NUMBER FROM PARTS LIST IN FRONT COVER BEFORE SELECTING REPLACEMENT ITEM NUMBER**

TWO DIGIT CODE	COMPONENT ASSEMBLY NUMBER	GEAR RATIO	HIGH SPEED GEAR (ITEM 52)	DISC (ITEM 46)	LOAD BRAKE ASM (ITEM 47)	2ND REDUCTION PINION (ITEM 50)	DRIVING PINION (ITEM 45)
<b>STANDARD EW</b>							
05	6407937-05	73.1	6423356-01 (88 TEETH)	6433966-00	6452334-00	6423396-00 (14 TEETH)	6455986-01 (25 TEETH)
06	6407937-06	96.6	6423356-02 (93 TEETH)	6433966-00	6452334-00	6423396-00 (14 TEETH)	6455986-02 (20 TEETH)
07	6407937-07	117.3	6423356-03 (96 TEETH)	6433966-00	6452334-00	6423396-00 (14 TEETH)	6455986-03 (17 TEETH)
08	6407937-08	159.7	6423356-04 (86 TEETH)	6433966-00	6452334-00	6423396-00 (14 TEETH)	6455986-04 (13 TEETH)
10	6407937-10	63.0	6423356-05 (85 TEETH)	6433966-00	6452334-00	6423396-00	645986-05 (28 TEETH)
<b>EW WITHOUT LOAD BRAKE</b>							
01	6407937-01	73.1	6437484-01 (88 TEETH)	N/A	N/A	6437804-00 (14 TEETH)	6455986-01 (25 TEETH)
02	6407937-02	96.6	6437484-02 (93 TEETH)	N/A	N/A	6437804-00 (14 TEETH)	6455986-02 (20 TEETH)
03	6407937-03	117.3	6437484-03 (96 TEETH)	N/A	N/A	6437804-00 (14 TEETH)	6455986-03 (17 TEETH)
04	6407937-04	159.7	6437484-04 (100 TEETH)	N/A	N/A	6437804-00 (14 TEETH)	6455986-04 (13 TEETH)
09	6407937-09	63.0	6437484-05 (85 TEETH)	N/A	N/A	6437804-00 (14 TEETH)	6455986-05 (28 TEETH)
<b>EW EXPLOSION PROOF</b>							
01	6427062-01	73.1	6423356-01 (88 TEETH)	6433966-00	6452334-00	6423396-00 (14 TEETH)	6443671-01 (25 TEETH)
02	6427062-02	96.6	6423356-02 (93 TEETH)	6433966-00	6452334-00	6423396-00 (14 TEETH)	6443671-02 (20 TEETH)
03	6427062-03	117.3	6423356-03 (96 TEETH)	6433966-00	6452334-00	6423396-00 (14 TEETH)	6443671-03 (17 TEETH)
04	6427062-04	159.7	6423356-04 (100 TEETH)	6433966-00	6452334-00	6423396-00 (14 TEETH)	64443671-04 (13 TEETH)
05	6427062-05	63.0	6423356-05 (85 TEETH)	6433966-00	6452334-00	6423396-00	6443671-09 (28 TEETH)
<b>EW HEAVY DUTY</b>							
11	6407937-11	63.0	6474921-05 (85 TEETH)	6475031-00	6474881-00	6423396-00 (14 TEETH)	6455986-05 (25 TEETH)
12	6407937-12	73.1	6474921-01 (88 TEETH)	6475031-00	6474881-00	6423396-00 (14 TEETH)	6455986-01 (20 TEETH)
13	6407937-13	96.6	6474921-02 (93 TEETH)	6475031-00	6474881-00	6423396-00 (14 TEETH)	6455986-02 (17 TEETH)
14	6407937-14	117.3	6474921-03 (96 TEETH)	6475031-00	6474881-00	6423396-00 (14 TEETH)	6455986-03 (13 TEETH)
15	6407937-15	159.7	6474921-04 (100 TEETH)	6475031-00	6474881-00	6423396-00 (14 TEETH)	6455986-04 (28 TEETH)
<b>STANDARD AW</b>							
16	6407937-16	63.0	6423356-05 (25 TEETH)	6433966-00	6452334-00	8412296-00 (14 TEETH)	6450293-05 (28 TEETH)
17	6407937-17	73.1	6423356-01 (88 TEETH)	6433966-00	6452334-00	6423396-00 (14 TEETH)	6450293-01 (25 TEETH)
18	6407937-18	96.6	6423356-02 (93 TEETH)	6433966-00	6452334-00	6423396-00 (14 TEETH)	6450293-02 (20 TEETH)
19	6407937-19	117.3	6423356-03 (96 TEETH)	6433966-00	6452334-00	6423396-00 (14 TEETH)	6450293-03 (17 TEETH)
20	6407937-20	159.7	6412246-04 (100 TEETH)	6433966-00	6452334-00	6423396-00 (14 TEETH)	6450293-04 (13 TEETH)

**WHEN REPLACEMENT PARTS ARE NEEDED, ORDER ONLY YALE © FACTORY ENGINEERED PARTS**  
 EW / AW SERIES

**SECTION 1340****GEARING &  
LOAD BRAKE****RECOMMENDED SPARE PARTS LIST FOR ONE YEAR OPERATION****LOAD BRAKE KIT - STANDARD DUTY**

ITEM NUMBER	COMPLETE KIT PART NUMBER	PART NO.	QTY.
47	RATCHET DISC	6452334-00	1

**LOAD BRAKE KIT - HEAVY DUTY**

ITEM NUMBER	COMPLETE KIT PART NUMBER	PART NO.	QTY.
47A	RATCHET DISC	6474881-00	1

**GEARCASE SEAL PACKAGE**

ITEM NUMBER	COMPLETE KIT PART NUMBER	PART NO.	QTY.
		6460182-00	1
4	GASKET	6437554-00	2
6	SCREW	6441518-00	36
8	SEAL	6441468-00	1
10	O RING	0664140-00	1
15	GASKET	6439564-00	2
27	SEAL, DRIVE PINION	6401229-05	1
31	GASKET	6436744-02	1
33	SEAL	6441478-00	1
35	GASKET	6443558-00	2
63	THREAD SEAL	6459728-00	6
65	GASKET	6442523-00	1
73	LIQUID GASKET	6451523-02	1

(SEC1340F.PTS)

# Yale Hoisting Equipment

EW SERIES

## STANDARD HEADROOM

### UPPER PLUGGING L/S

**IMPORTANT**  
SELECT COMPONENT ASSEMBLY NUMBER FROM PARTS LIST IN FRONT COVER BEFORE SELECTING REPLACEMENT ITEM NUMBER

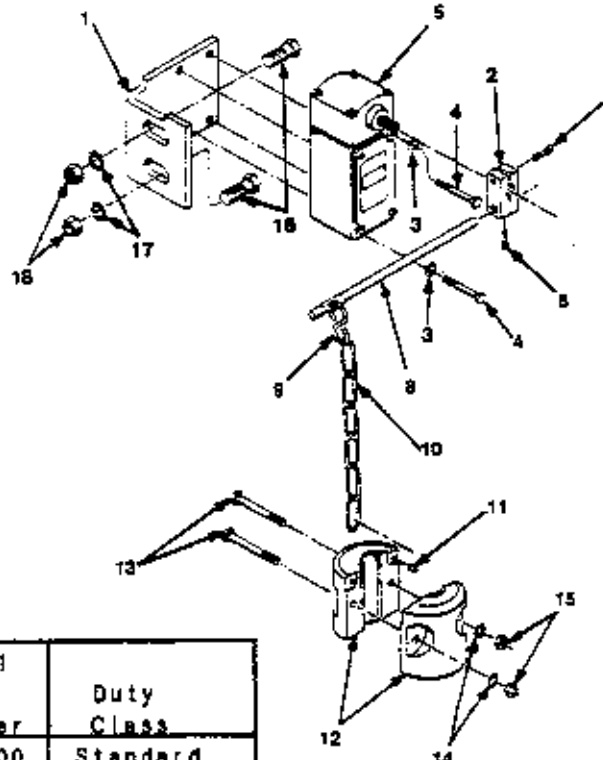

TABLE 1

Component Number	Item No. 5 Switch Part Number	Item No. 1 Bracket Part Number	Duty Class
6449452-00	6455201-00	6486411-00	Standard
6449492-00	6461041-00	6486851-00	Exp. Proof
6452242-00	6487701-00	6487731-00	Standard
6452252-00	6488331-00	6487781-00	Exp. Proof

ITEM	PART NO.	DESCRIPTION	QTY.
1	SEE TABLE 1	L.S. MTG. BRKT. ....	1
2	6467791-00	HUB .....	1
3	0150285-00	LOCKWASHER NO. 10 .....	2
4	0148768-00	R.H. SCREW 10-32 .....	2
5	SEE TABLE 1	LIMIT SWITCH .....	1
6	0656254-00	SOCKET SCREW 10-32 x 3/8 .....	1
7	0656255-00	SOCKET SCREW 10-32 x 5/8 .....	1
8	6483211-00	L.S. ROD .....	1
9	0591497-00	S-HOOK .....	1
10	6450221-79	CONTROL CHAIN .....	*
11	0105760-00	L.S. WEIGHT PIN .....	2
12	6495351-00	L.S. WEIGHT .....	2
13	0109484-00	R.H. SCREW 1/4-20 x 1 3/4 .....	2
14	0150308-00	LOCKWASHER 1/4 in. ....	2
15	0149707-00	JAM NUT 1/4-20 .....	2
16	0554850-00	SCREW 1/2-13 x 1 1/4 .....	2
17	0150266-00	LOCKWASHER 1/2 in. ....	2
18	0149708-00	NUT 1/2 .....	2

\*SPECIFY LENGTH

08-041

FORM NO. 165-908-041

**When Replacement Parts Are Needed, Order Only Yale® Factory Engineered Parts**

JULY 1983

EW SERIES



**SECTION 1410**

**LIMIT SWITCH  
EW SERIES**

**CLOSE HEADROOM  
UPPER PLUGGING L/S**

**IMPORTANT  
SELECT COMPONENT ASSEMBLY  
NUMBER FROM PARTS LIST IN FRONT  
COVER BEFORE SELECTING  
REPLACEMENT ITEM NUMBER**

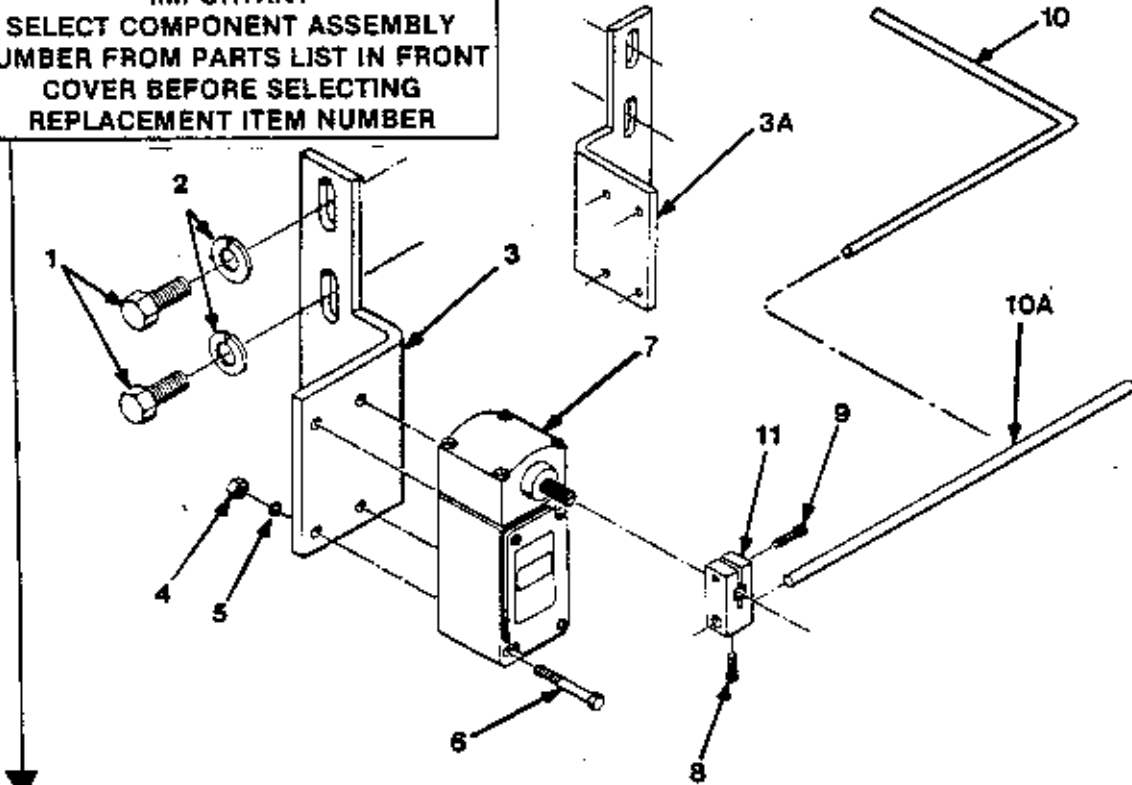

**TABLE 2**

Component	Item No. 7 Switch	Item No. 3 Bracket	Enclosure
Number	Part Number	Part Number	Type
6448322-00	6455291-00	6477551-00	Standard
6448332-00	6455291-00	6477591-00	Standard
6452122-00	6461041-00	6487341-00	Exp. Proof
6452132-00	6461041-00	6487361-00	Exp. Proof

ITEM	PART NO.	DESCRIPTION	QTY.
1	0597115-00	BOLT 3/8 - 16 x 3/4 in. ....	2
2	0150264-00	LOCKWASHER 3/8 in. ....	2
3	SEE TABLE 2	BRACKET .....	1
4	0149393-00	NUT 10 - 32 .....	2
5	0150285-00	LOCKWASHER NO. 10 .....	2
6	0148768-00	MACHINE SCREW 10 - 32 x 2 .....	2
7	SEE TABLE 2	LIMIT SWITCH .....	1
8	0656254-00	SCREW 10 - 32 x 3/8 .....	1
9	0656255-00	SCREW 10 - 32 x 5/8 .....	1
10	6477621-00	ROD, LIMIT SWITCH 90° BEND .....	1
10A	6467771-00	ROD, LIMIT SWITCH .....	1
11	6467791-00	HUB .....	1

08-041  
FORM NO. 185-908-041

**When Replacement Parts Are Needed, Order Only Yale® Factory Engineered Parts**

JULY 1983

EW SERIES

# Yale Hoisting Equipment

EW SERIES ALL CHASSIS ELECTRIC HOIST TRAVELING NUT GEARED L / SWITCH ASSEMBLY

**IMPORTANT**  
SELECT COMPONENT ASSEMBLY NUMBER FROM PARTS LIST IN FRONT COVER BEFORE SELECTING REPLACEMENT ITEM NUMBER

SECTION 1420 / 30  
LIMIT SWITCH

TWO DIGIT CODE IS THE LAST TWO DIGITS OF THE COMPONENT NUMBER AND IS STAMPED IN THIS LOCATION.

Two Digit Code	Component Number	Two Digit Code	Component Number
01	6449811-01	18	6449811-18
02	6449811-02	19	6449811-19
03	6449811-03	20	6449811-20
04	6449811-04	21	6449811-21
17	6449811-17	22	6449811-22

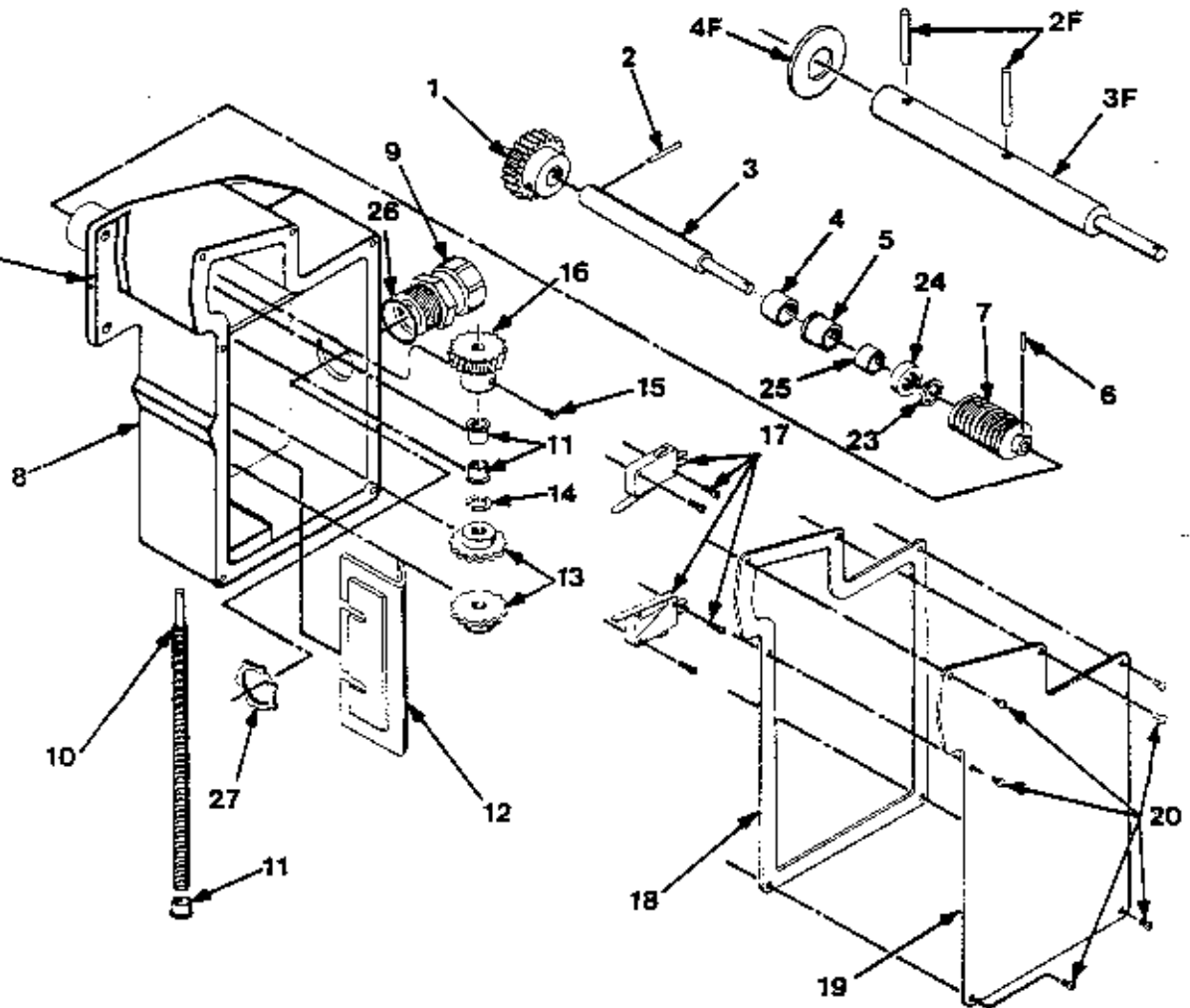

## Adjustment

YD - 0251

To adjust the limit switches or to set them at other desired levels remove the limit switch cover. Run the unit down noticing the switch toward which the nut travels. Stop the bottom block at the desired lower limit. Remove the flat bar under the traveling nuts. Move the nut nearest the switch until the switch can be heard to trip. Replace the flat bar under the traveling nuts. Repeat the above to set the upper limit switch.

FORM NO. 165-908-027

**When Replacement Parts Are Needed, Order Only Yale® Factory Engineered Parts**

**LIMIT SWITCH  
TRAVELING NUT GEARED LIMIT SWITCH ASSEMBLY**

ITEM	PART NO.	DESCRIPTION	QTY.
1	6412881-00	PINION SPUR GEAR	1
2	SEE CHART 1	ROLL PIN	1
2F	SEE CHART 1	ROLL PIN	2
3	SEE CHART 1	SHAFT	1
3F	SEE CHART 1	SHAFT	1
4	SEE CHART 1	SPACER	1
4F	0161144-00	WASHER	1
5	6412861-00	FLANGE BEARING OLITE	1
6	0318081-00	ROLL PIN	1
7	SEE CHART 2	WORM GEAR	1
8	6426304-00	HOUSING	1
9	0103721-00	WATERTIGHT CONNECTOR	2
10	6412891-00	SHAFT (24 THREADS/INCH)	1
	6449011-00	SHAFT (32 THREADS/INCH)	1
11	6412871-00	FLANGE BEARING	3
12	6449101-00	NUT RETAINER	1
13	6440883-00	TRAVELING NUT (24 THREADS/INCH)	2
	6449111-00	TRAVELING NUT (32 THREADS/INCH)	2
14	6409191-00	RETAINING RING	1
15	0109562-00	SET SCREW	1
16	SEE CHART 2	GEAR	1
17	6402056-00	SWITCH AND ACTUATOR	2
18	6422173-00	GASKET	1
19	6422143-00	COVER	1
20	6401209-02	SCREW	6
21	6436528-08	WIRE TERMINAL (NOT SHOWN)	4
22	6431251-81	WIRE - 5 FEET (NOT SHOWN)	1
23	0114291-00	FLAT WASHER	1
24	6453716-00	SEAL	1
25	0608407-00	OILITE BEARING	1
26	6492891-02	SEALING RING	1
27	0103740-00	LOCKNUT	1

**CHART 1**

TWO DIGIT CODE	COMPONENT NUMBER	SHAFT ITEM NO. 3 - 3F	SPACER ITEM NO. 4	ROLL PIN ITEM 2 - 2F
01 & 17	6449811-01 & 17	6452251-05	0116311-00	0230207-00
02 & 18	6449811-02 & 18	6452251-06	0116312-00	0230207-00
03 & 19	6449811-03 & 19	6452251-07	0116313-00	0230207-00
04 & 20	6449811-04 & 20	6452251-08	0116314-00	0230207-00
21 & 22	6449811-21 & 22	6429573-00	N/A	6401689-02

**CHART 2**

COMPONENT NUMBER	RATIO	GEAR ITEM NO. 16	WORM ITEM NO. 7
6449811-01, 02, 03, 04 & 21	2.5:1	6412951-00 20 TEETH	6412921-00 4 START
6449811-17, 18, 19, 20 & 22	5:1	6412941-00 20 TEETH	6412931-00 2 START

FORM NO. 165-908-027

**When Replacement Parts Are Needed, Order Only Yale Factory Engineered Parts**  
 EW SERIES 2 OCTOBER 1996

# Yale Hoisting Equipment

## SECTION 1420 / 30 LIMIT SWITCH

**IMPORTANT**  
SELECT COMPONENT ASSEMBLY  
NUMBER FROM PARTS LIST IN FRONT  
COVER BEFORE SELECTING  
REPLACEMENT ITEM NUMBER

- 6432652 \_\_\_
- 6432662 \_\_\_
- 6432672 \_\_\_
- 6432682 \_\_\_
- 6432692 \_\_\_

EW SERIES- ALL CHASSIS ELECTRIC HOIST  
GEARED LIMIT SWITCH STANDARD & EXPLOSION PROOF UNITS

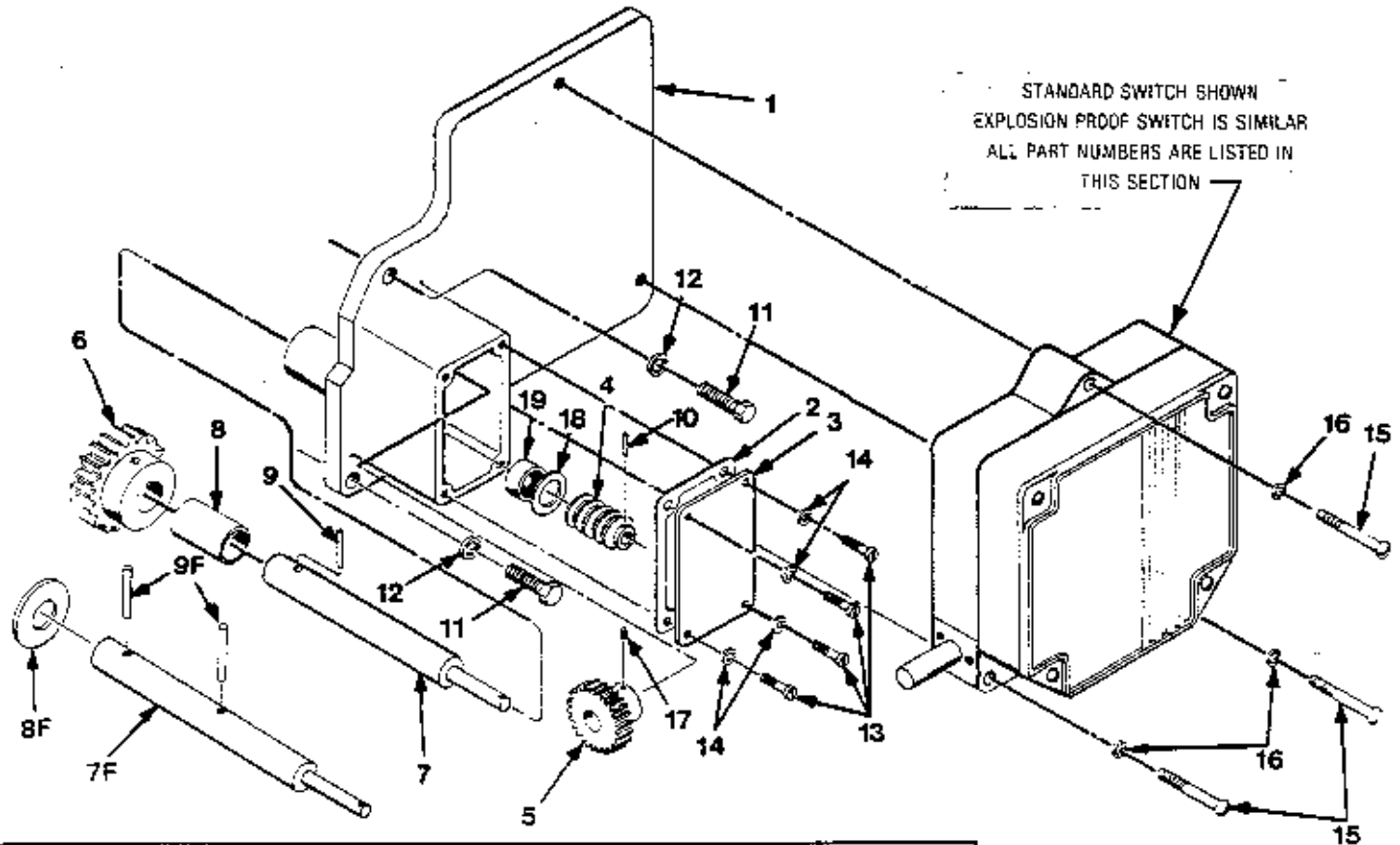

CHASSIS & GEAR TRAIN SIZE	ENCLOSURE TYPE	LIMIT SWITCH MOUNTING PARTS GROUP INCLUDES ITEMS (1 thru. 19)	
		2- START WORM & GEAR	4- START WORM & GEAR
BEW <input checked="" type="checkbox"/> —	NEMA 4	6432752-00	
BEW <input checked="" type="checkbox"/> —	EXP. PROOF	6432702-00	
BEW <input checked="" type="checkbox"/> X	NEMA 4	6432762-00	6452472-00
CEW <input checked="" type="checkbox"/> —	EXP. PROOF	6432712-00	
CEW <input checked="" type="checkbox"/> X	NEMA 4	6432772-00	
DEW <input checked="" type="checkbox"/> —	EXP. PROOF	6432722-00	
DEW <input checked="" type="checkbox"/> X	NEMA 4	6432782-00	6444612-00
EEW <input checked="" type="checkbox"/> —	EXP. PROOF	6432732-00	6451042-00
EEW <input checked="" type="checkbox"/> X	NEMA 4	6432792-00	
FEW <input checked="" type="checkbox"/> —	EXP. PROOF	6432742-00	

SEE PAGE 5 FOR INTERNAL PARTS OF LIMIT SWITCH

**When Replacement Parts Are Needed, Order Only Yale® Factory Engineered Parts**

**SECTION 1420 / 30**

**LIMIT SWITCH**

**EW SERIES ALL CHASSIS  
GEARED LIMIT SWITCH - STANDARD & EXPLOSION PROOF UNITS**

ITEM	PART NO.	DESCRIPTION	QTY.
1	6450321-00	GEAR CASE (FOR STANDARD UNIT) . . . . .	1
	6450331-00	GEARCASE (FOR EXPLOSION PROOF UNITS) . . . . .	1
2	6459091-00	GASKET . . . . .	1
3	6450551-00	COVER . . . . .	1
4	6412921-00	WORM . . . . .	1
5	6450301-00	HELICAL GEAR (20 TEETH) . . . . .	1
6	6412881-00	PINION, SPUR GEAR . . . . .	1
7	SEE TABLE 1	SHAFT . . . . .	1
7F	6443213-00	SHAFT (Used On Component No. 6432692) . . . . .	1
	6470561-00	SHAFT (Used On Component No. 6432692) . . . . .	1
8	SEE TABLE 2	SPACER . . . . .	1
8F	0161144-00	WASHER (Used On Component NO. 6432692) . . . . .	1
9	SEE TABLE 2	ROLL PIN . . . . .	1
9F	SEE TABLE 2	ROLL PIN (Used On Component No. 6432692) . . . . .	2
10	0318061-00	ROLL PIN (WORM GEAR) . . . . .	1
11	0622328-00	SCREW (GEARCASE) . . . . .	3
	0629135-00	SCREW (Used On Component No. 6432692) . . . . .	3
12	0150262-00	WASHER (GEARCASE MTG.) . . . . .	3
13	0109468-00	SCREW (COVER PLATE) . . . . .	4
14	0150377-00	LOCKWASHER (COVER PLATE) . . . . .	4
15	0148641-00	SCREW (LIMIT SWITCH MTG. - STANDARD) . . . . .	3
	0109224-00	SCREW (LIMIT SWITCH MTG. - EXPLOSION PROOF) . . . . .	3
16	0150256-00	LOCKWASHER (STANDARD SWITCH) . . . . .	3
	0150319-00	LOCKWASHER (EXPLOSION PROOF SWITCH) . . . . .	3
17	0109562-00	SOCKET HEAD SET SCREW . . . . .	1
18	0114291-00	FLAT WASHER (BRASS) . . . . .	1
19	6453718-00	SEAL . . . . .	1

TABLE 1 - SHAFT (ITEM 7)

COMPONENT NO.	STANDARD SWITCH	EXPLOSION PROOF
6432652	6452251-01	6452251-05
6432662	6452251-02	6452251-06
6432672	6452251-03	6452251-07
6432682	6452251-04	6452251-08
6432692	SEE ITEM 7F	SEE ITEM 7F

TABLE 2

COMPONENT NO.	SPACER - ITEM 8	ROLL PIN - ITEM 9 & 9F
6432652	0116311-00	0230207-00
6432662	0116312-00	0230207-00
6432672	0116313-00	0230207-00
6432682	0116314-00	0230207-00
6432692	N/A	6401689-02

FORM NO. 185-908-039

**When Replacement Parts Are Needed, Order Only Yale® Factory Engineered Parts**

EW SERIES

# Yale Hoisting Equipment

**SECTION 1420/30**

**LIMIT SWITCH**

EW SERIES- ALL CHASSIS ELECTRIC HOIST  
GEARED LIMIT SWITCH STANDARD & EXPLOSION PROOF UNITS

- 6432652 \_\_\_\_\_
- 6432662 \_\_\_\_\_
- 6432672 \_\_\_\_\_
- 6432682 \_\_\_\_\_
- 6432692 \_\_\_\_\_

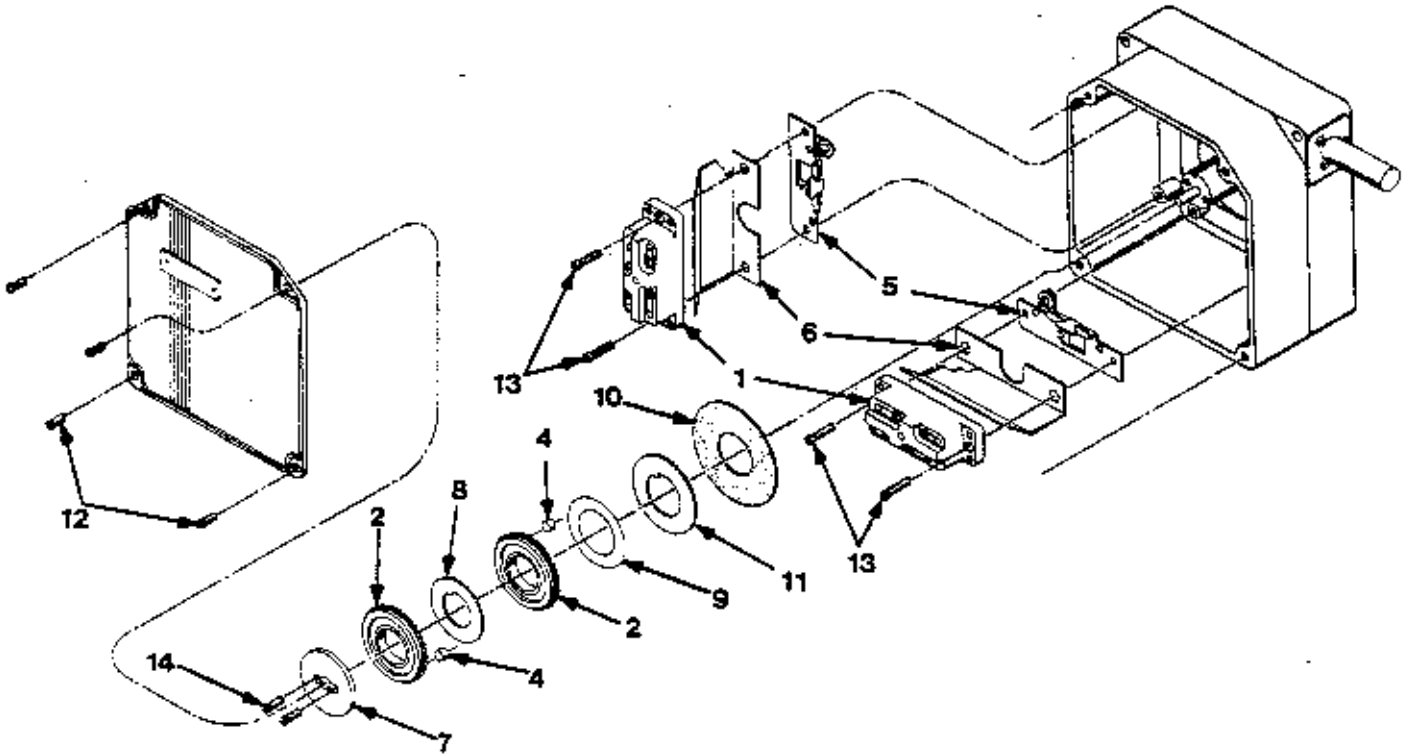

ITEM	PART NO.	DESCRIPTION	QTY.
1	6492221-01	CONTACT UNIT (1 NO - 1 NC)	★
	6492221-02	CONTACT UNIT (1 NC)	★
2	6492221-03	CAM (STANDARD)	★
	6492221-04	CAM (45° DWELL)	★
4	6492221-05	ROLLER FOR CAM	★
5	6492221-06	PINION AND BRACKET	★
6	6492221-07	INSULATOR	★
7	6492221-08	CLAMPING PLATE	1
8	6492221-09	SPACER WASHER	★
9	6492221-10	SPRING WASHER	1
10	6492221-11	CLUTCH DISC	1
11	6492221-12	RETAINER WASHER	1
12	.	COVER SCREW NO. 6 - 32 X 3/8	
13	.	CONTACT MOUNTING SCREW NO. 6 - 32 X 5/8 SEMS	
14	.	CAM CLAMPING SCREW NO. 6 - 32 X 3/8 SEMS	

★ QUANTITY AS REQUIRED.

• STANDARD HARDWARE ITEMS - OBTAIN LOCALLY

YE 0523  
FORM NO. 165-908-039

**When Replacement Parts Are Needed, Order Only Yale® Factory Engineered Parts**

REV. JULY 1983

EW SERIES

**SECTION 1420 / 30****LIMIT SWITCH****EW SERIES - ALL CHASSIS  
GEARED LIMIT SWITCH STANDARD AND EXPLOSION PROOF UNITS****ADJUSTMENT**

The limit switch cams are set at the factory for maximum lift. If re-adjustment is necessary, the following procedure should be followed.

 **WARNING!** If equipment is located in a hazardous area, be sure power is off before opening cover.

1. Remove limit switch cover.
2. Loosen the two cam clamping screws one half turn each.
3. Locate the adjusting pinion for the cam which requires re-adjustment by referring to the arrow on the contact unit insulator.
4. Depress pinion with a screwdriver to engage gears. Rotate the cam to the desired setting. The white mark on the gear teeth is directly over the cam lobe that trips the switch.
5. Tighten the cam clamping screws and replace the limit switch cover.

**MAINTENANCE****LUBRICATION**

The limit switch has been permanently lubricated at the factory. An increase in life may be obtained by occasionally placing a small amount of gear grease on the worm and worm gear.

**CONTACT UNIT REPLACEMENT**

If a contact unit should require replacement, the following procedure should be followed to ensure proper operation of the limit switch.

 **WARNING!** If equipment is located in a hazardous area, be sure power is off before opening cover.

1. Remove the limit switch cover.
2. Remove the defective contact unit.
3. Turn the cam so that the cam lobe is away from the cam follower.
4. Install the new contact unit and the insulator, pushing the bracket toward the center post as far as possible.
5. Tighten both mounting screws.
6. Loosen both mounting screws one half turn.
7. Loosen the cam clamping screws one half turn each.
8. Using the adjusting pinion, rotate the cam lobe past the cam follower. This will push the bracket into the proper position.
9. Re-tighten the contact unit mounting screws.
10. Re-adjust cam by following the instructions given under **ADJUSTMENT**.

**When Replacement Parts Are Needed, Order Only Yale® Factory Engineered Parts**

# Yale Hoisting Equipment

**SECTION 1442**  
**LOAD LIMITER**

EW SERIES  
DEAD END ROPE ARRANGEMENT  
S2 - S4 STD. HDRM. / WITH LOAD LIMITER

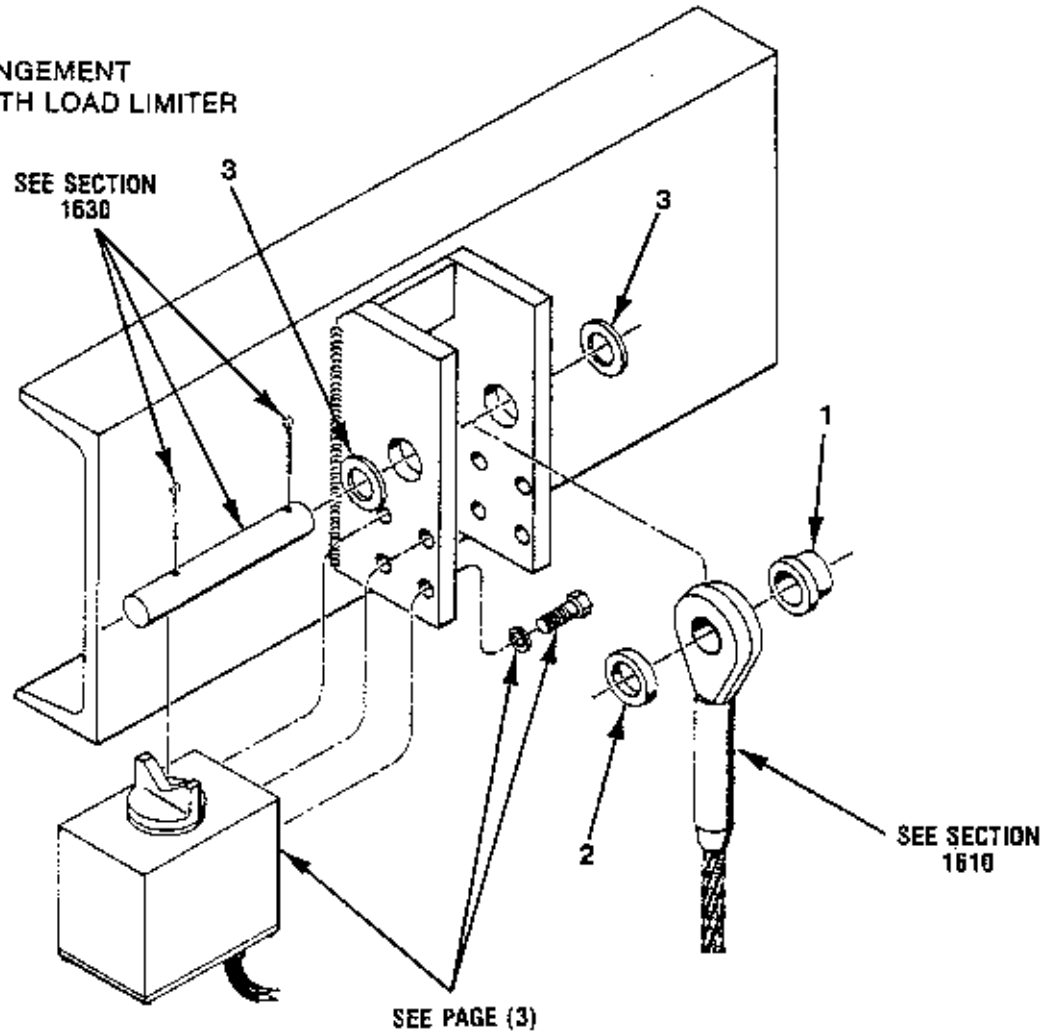

ROPE DIA.	ITEM 1 SHOULDER SPACER	ITEM 2 PLAIN SPACER	ITEM 3 WASHER
1/4	648743101	644486103	016110900
5/16	648743102	642446108	016111200
3/8	648743103	642446107	↓
7/16	648743102		
1/2	648743102		
5/8	648743104	644628316	053581900
3/4	648743105	644628317	016120100

FORM NO. 165-908-034

**When Replacement Parts Are Needed, Order Only Yale® Factory Engineered Parts**

APRIL, 1984

EW SERIES

Authorized Sales & Service - McLaughlin Hoist & Crane - For Parts or Service Call (636) 343-9700



**SECTION 1442**  
**LOAD LIMITER**  
**EW SERIES**  
**SHEAVE AND YOKE ARRANGEMENT**

D-2, D-4 AND D-6 LOW HDRM. / WITH LOAD LIMITER

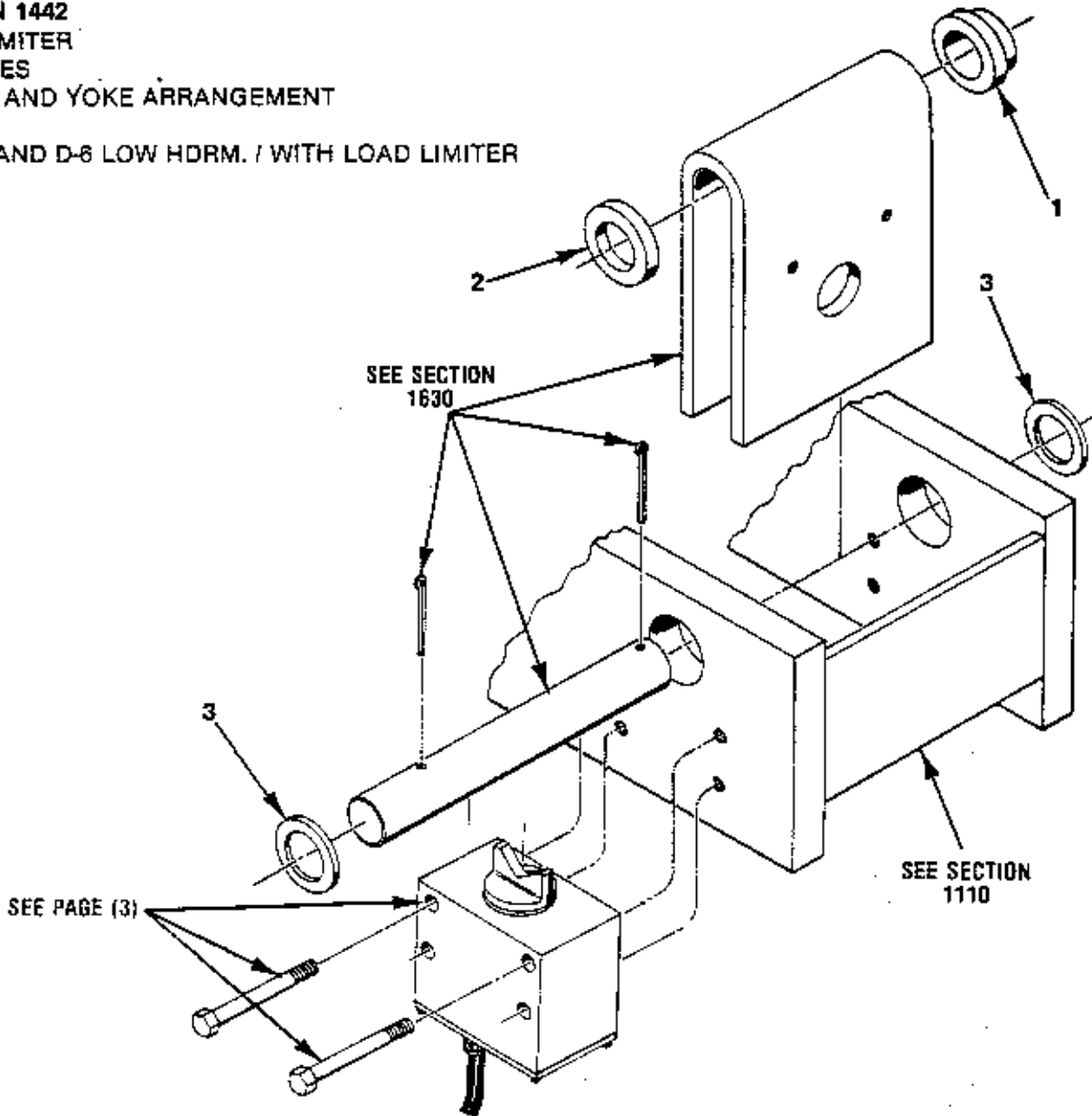

ROPE DIA. & REEVING	ITEM 1 SPACER	ITEM 2 PLAIN SPACER	ITEM 3 WASHER	QTY
1/4-5/16 D2-D4	6480911-05	6446283-13	6425151-08	2
5/16-3/8 D4	6428541-08	N/R	6425151-08	4
1/4-3/8 D2-D4	6428541-08	N/R	6425151-08	4
3/8-7/16 D2-D4	6428541-05	N/R	0236284-00	4
7/16-1/2 D2-D4	6428541-05	N/R	0236284-00	4
1/2-9/16 D2-D4	6446283-20	N/R	6421751-07	2
7/16-1/2 D6	6421741-05	N/R	6421751-08	2

N/R - NOT REQUIRED

FORM NO. 165-908-034-1

**When Replacement Parts Are Needed, Order Only Yale® Factory Engineered Parts**

**IMPORTANT**  
**SELECT COMPONENT ASSEMBLY**  
**NUMBER FROM PARTS LIST IN FRONT**  
**COVER BEFORE SELECTING**  
**REPLACEMENT ITEM NUMBER**

LOAD LIMITER

## EW SERIES

## OVERLOAD LIMIT SWITCH

## LIMIT SWITCH ASSEMBLY NUMBERS

6448482-01 (LOW HEADROOM) 1/2 - 7 1/2 TON - D2, 3 - 15 TON - D4, 20 TON - D6

6448482-02 (LOW HEADROOM) 10 - 15 TON - D2, 20 - 25 TON - D4, 25 - 35 TON - D6

6448482-03 (STANDARD HEADROOM) 1/2 - 7 1/2 TON - S2, 3 - 15 TON - S4

6448482-04 (STANDARD HEADROOM) 10 - 15 TON - S2, 20 - 25 TON - S4

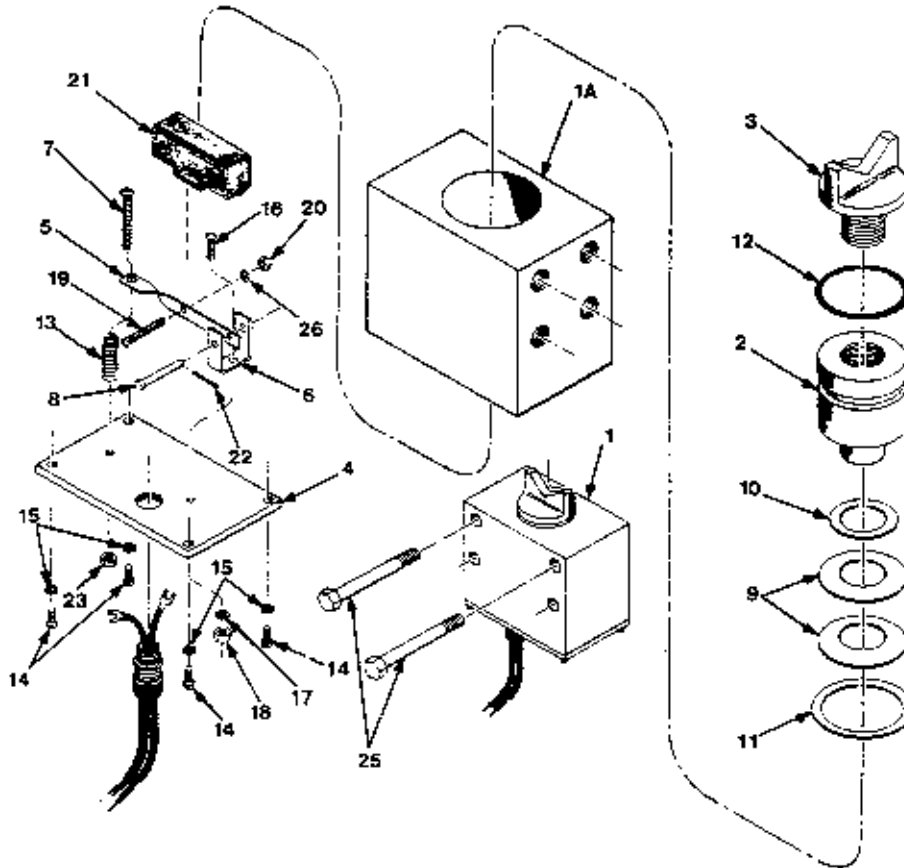

### To Calibrate the Load Limiter Switch:

1. Attach load to hook which meets the **minimum** desired weight limit **above** established limit of maximum hoisting performance.
2. Suspend the load approximately 1/2 - 1" above normal load surface.
3. Turn main power supply "OFF".
4. Refer to wiring diagram WDX□XX for your equipment that the fifth digit must be 1, or 3, or 4 or 7.
5. Loosen hex jam nut on slotted adjusting screw and turn adjusting screw "CLOCKWISE" until ohm meter verifies continuity between terminals 1 and 7.
6. While maintaining the position of the adjusting screw, tighten the hex jam nut to lock the screw in place.
7. Turn main power supply "ON" and lower the test load to normal load surface.
8. Try to raise the load; if load is raised beyond your specified limits, repeat steps 2 through 6.

STANDARD HEADROOM & LOW HEADROOM ASM. SAME EXCEPT FOR HOUSING MOUNTING HOLES

FORM NO 165-908-034

**When Replacement Parts Are Needed, Order Only Yale Factory Engineered Parts**

JUNE 1983

3

EW SERIES

COMMON PARTS			
ITEM	PART NO.	DESCRIPTION	QTY.
1	SEE TABLE	HOUSING (SIDE MOUNT) .....	1
	SEE TABLE	HOUSING (END MOUNT) .....	1
2	6483721-00	PLUNGER .....	1
3	6483731-00	ADJUSTING BLOCK .....	1
4	6483701-00	COVER (LIMIT SWITCH) .....	1
5	6453923-00	BRACKET (SWITCH) .....	1
6	6454013-00	MOUNTING BRACKET .....	1
7	6483681-00	ADJUSTING SCREW .....	1
8	6483671-00	CLEVIS PIN .....	1
9	6402478-17	BELLEVILLE SPRING .....	1
10	6484161-02	THRUST WASHER (1.56 O.D.) .....	1
11	6484161-01	THRUST WASHER (2.062 O.D.) .....	1
12	0128244-00	"O" RING .....	1
13	0167773-00	SPRING .....	1
14	0148633-00	SCREW (COVER) .....	4
15	0114108-00	LOCKWASHER (CAD. PLATED) .....	4
16	0148615-00	SCREW (MTG. BRACKET) .....	1
17	0114099-00	LOCKWASHER (SHAKEPROOF) .....	1
18	0149360-00	NUT (MTG. BRACKET) .....	1
19	0210676-00	ROUND HEAD SCREW .....	1
20	0211973-00	HEX NUT .....	1
21	6484141-00	MICRO SWITCH .....	1
22	0102775-00	COTTER PIN .....	1
23	0149393-00	HEX NUT (ADJUSTING SCREW) .....	1
24	0150266-00	LOCKWASHER, 1/2 MED. (NOT SHOWN) .....	4
25	2031527-00	SCREW, 1/2 - 13 (NOT SHOWN) LOW HEADROOM .....	AR**
	0554850-00	SCREW, 1/2 - 13 (NOT SHOWN) STD. HEADROOM .....	4
26	0515453-00	LOCKWASHER, SHAKEPROOF .....	1

\* SEE TABLE FOR QUANTITY REQUIRED.

\*\*AR AS REQUIRED FOR FRAME MTG. BRACKET.

LOAD LIMITER ASSEMBLY NUMBER	TYPE OR MOUNT	HOUSING ITEM 1	BELLEVILLE SPRING ITEM 9 QUANTITY
6448482-01	SIDE MOUNT OR LOW HEADROOM	6483741-00	1
6448482-02	SIDE MOUNT OR LOW HEADROOM	6483741-00	2
6448482-03	END MOUNT OR STD. HEADROOM	6483751-00	1
6448482-04	END MOUNT OR STD. HEADROOM	6483751-00	2

FORM NO. 165-908-034-4

**When Replacement Parts Are Needed, Order Only Yale® Factory Engineered Parts**

JUNE 1983

4

EW SERIES

# Yale Hoisting Equipment

SECTION 1630

REEVING KIT

EW SERIES

**IMPORTANT**  
**SELECT COMPONENT ASSEMBLY**  
**NUMBER FROM PARTS LIST IN FRONT**  
**COVER BEFORE SELECTING**  
**REPLACEMENT ITEM NUMBER**

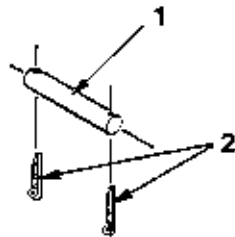

S2

FIGURE 1

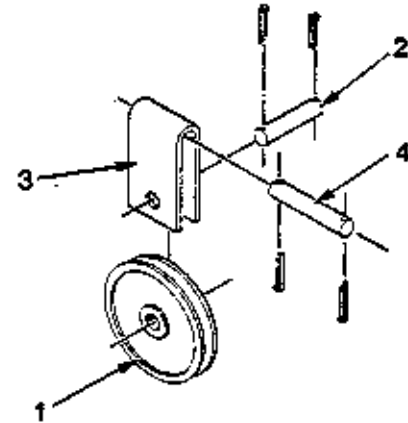

D2

FIGURE 2

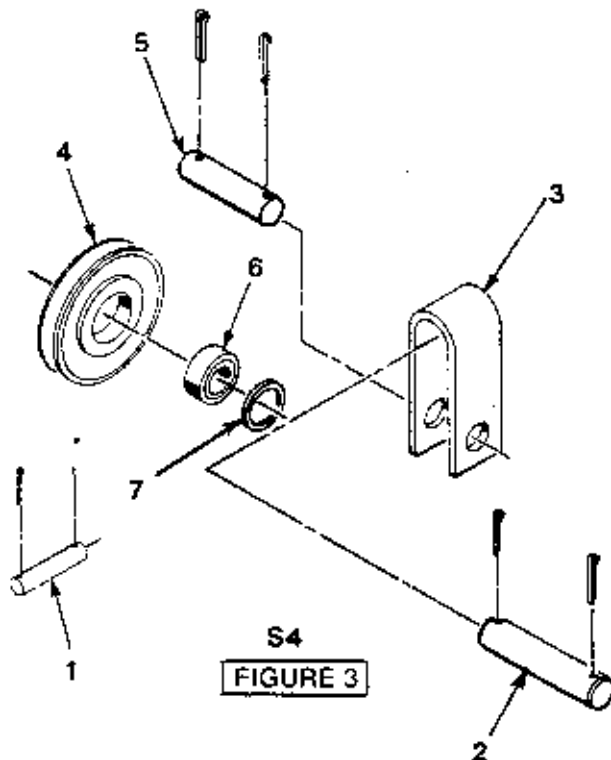

S4

FIGURE 3

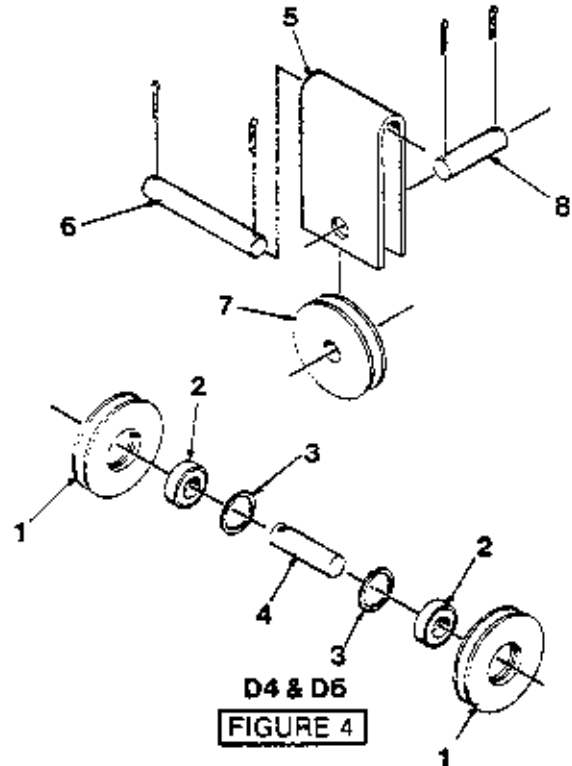

D4 & D6

FIGURE 4

03-110-5  
FORM NO. 165-903-110

**When Replacement Parts Are Needed, Order Only Yale® Factory Engineered Parts**

### DETERMINE WIRE ROPE DIAMETER

SEE PARTS LIST IN FRONT COVER FOR WIRE ROPE ASM NUMBER

#### EXAMPLE

TYPICAL ROPE DESCRIPTION

DESCRIPTION	COMPONENT	SEC.
ROPE ASM <span style="border: 1px solid black; padding: 2px;">31</span> S060-S6X19-053	644728201	1610

↓

ROPE DIAMETER  
31 — 5/16 in. NOMINAL

NOTE: 31 DESIGNATES NOMINAL ROPE DIAMETER.

#### SIZES AVAILABLE

- 25 — 1/4 in.
- 31 — 5/16 in.
- 37 — 3/8 in.
- 43 — 7/16 in.
- 50 — 1/2 in.
- 56 — 9/16 in.
- 62 — 5/8 in.
- 75 — 3/4 in.

# Yale Hoisting Equipment

**SECTION 1630**

**REEVING KIT**

**EW SERIES**

1. SELECT CHASSIS & REEVING
2. DETERMINE WIRE ROPE DIAMETER (SEE SECTION B)
3. USE TABLES TO SELECT REPLACEMENT PARTS

**S2 - REEVING TABLE**

Chassis	Reev-ing	Rope Dia.	Item No.	Part Number	Description	Fig. No.
BEW & CEW	S2	1/4	1	6444951-07	Rope Anchor Pin .....	1
BEW CEW & DEW	S2	5/16, 7/16, & 1/2		6444951-08	Rope Anchor Pin .....	1
DEW	S2	5/8		6487921-01	Rope Anchor Pin .....	1
EEW	S2	7/16, 1/2 & 5/8		6487921-01	Rope Anchor Pin .....	1
EEW	S2	3/4		6487921-01	Rope Anchor Pin .....	1
FEW	S2	1/2		6444951-02	Rope Anchor Pin .....	1
FEW	S2	5/8		6487921-05	Rope Anchor Pin .....	1
FEW	S2	3/4		6487921-06	Rope Anchor Pin .....	1
BEW & CEW	S2	1/4	2	0381401-00	Cotter Pin .....	1
BEW, CEW & DEW	S2	5/16, 7/16, & 1/2		0381401-00	Cotter Pin .....	1
DEW	S2	5/8		0154255-00	Cotter Pin .....	1
EEW	S2	7/16, 1/2, & 5/8		0154255-00	Cotter Pin .....	1
EEW	S2	3/4		0381403-00	Cotter Pin .....	1
FEW	S2	1/2		0154255-00	Cotter Pin .....	1
FEW	S2	5/8		0154236-00	Cotter Pin .....	1
FEW	S2	3/4		0154270-00	Cotter Pin .....	1

**D2 - REEVING TABLE**

Chassis	Reev-ing	Rope Dia.	Item No.	Part Number	Description	Fig. No.
BEW	D2	1/4 & 5/16	1	6479081-00	Equalizer Sheave .....	2
CEW & DEW		1/4, 5/16 & 3/8		6479081-00	Equalizer Sheave .....	2
DEW		7/16		6479071-00	Equalizer Sheave .....	2
EEW		3/8 & 7/16		6479071-00	Equalizer Sheave .....	2
EEW		1/2		6457761-00	Equalizer Sheave .....	2
FEW		7/16 & 1/2		6457761-00	Equalizer Sheave .....	2
BEW	D2	1/4 & 5/16	2	6454071-00	Equalizer Sheave Pin .....	2
CEW & DEW		1/4, 5/16 & 3/8		6454071-00	Equalizer Sheave Pin .....	2
DEW		7/16		6452031-05	Equalizer Sheave Pin .....	2
EEW		3/8 & 7/16		6452031-05	Equalizer Sheave Pin .....	2
EEW		1/2		6452031-07	Equalizer Sheave Pin .....	2
FEW		7/16 & 1/2		6452031-07	Equalizer Sheave Pin .....	2
BEW	D2	1/4 & 5/16	3	6452041-06	Yoke .....	2
CEW & DEW		1/4, 5/16 & 3/8		6452041-06	Yoke .....	2
DEW		7/16		6452041-09	Yoke .....	2
EEW		3/8 & 7/16		6452041-09	Yoke .....	2
EEW		1/2		6452041-12	Yoke .....	2
FEW		7/16 & 1/2		6452041-12	Yoke .....	2
BEW	D2	1/4 & 5/16	4	6480741-00	Yoke Shaft .....	2
CEW & DEW		1/4, 5/16 & 3/8		6480741-00	Yoke Shaft .....	2
DEW		7/16		6480731-00	Yoke Shaft .....	2
EEW		3/8 & 7/16		6480731-00	Yoke Shaft .....	2
EEW		1/2		6480721-00	Yoke Shaft .....	2
FEW		7/16 & 1/2		6480721-00	Yoke Shaft .....	2

03-110-3  
FORM NO. 165-903-110

**When Replacement Parts Are Needed, Order Only Yale® Factory Engineered Parts**

## 54. REEVING TABLE

Chassis	Reev- ing	Rope Dia.	Item No.	Part Number	Description	Fig. No.
BEW	S4	5/16	1	6444951-08	Rope Anchor Pin	3
BEW	S4	3/8		6444951-08	Rope Anchor Pin	3
CEW	S4	3/8		6444951-08	Rope Anchor Pin	3
CEW & DEW	S4	7/16 & 1/2		6444951-08	Rope Anchor Pin	3
DEW & EEW	S4	5/8		6487921-01	Rope Anchor Pin	3
EEW	S4	1/2		6444951-08	Rope Anchor Pin	3
EEW	S4	3/4		6487921-02	Rope Anchor Pin	3
FEW	S4	5/8		6443354-00	Rope Anchor Pin	3
FEW	S4	3/4		6443354-00	Rope Anchor Pin	3
BEW	S4	5/16		2	6443991-09	Yoke Shaft
BEW	S4	3/8	6486121-01		Yoke Shaft	3
CEW	S4	3/8	6443991-09		Yoke Shaft	3
CEW & DEW	S4	7/16 & 1/2	6486121-01		Yoke Shaft	3
DEW & EEW	S4	5/8	6444001-12		Yoke Shaft	3
EEW	S4	1/2	6486121-01		Yoke Shaft	3
EEW	S4	3/4	6444001-13		Yoke Shaft	3
FEW	S4	5/8	6487921-03		Yoke Shaft	3
FEW	S4	3/4	6487921-04		Yoke Shaft	3
BEW	S4	5/16	3		6482841-01	Yoke
BEW	S4	3/8		6482841-02	Yoke	3
CEW	S4	3/8		6482841-01	Yoke	3
CEW & DEW	S4	7/16 & 1/2		6482841-02	Yoke	3
DEW & EEW	S4	5/8		6482841-03	Yoke	3
EEW	S4	1/2		6482841-02	Yoke	3
EEW	S4	3/4		6482841-04	Yoke	3
FEW	S4	5/8		6443354-00	Yoke	3
FEW	S4	3/4		6443354-00	Yoke	3
BEW	S4	5/16		4	0109885-00	Idler Sheave
BEW	S4	3/8	0109996-00		Idler Sheave	3
CEW	S4	3/8	0109885-00		Idler Sheave	3
CEW & DEW	S4	7/16 & 1/2	0109996-00		Idler Sheave	3
DEW & EEW	S4	5/8	0109946-00		Idler Sheave	3
EEW	S4	1/2	0109996-00		Idler Sheave	3
EEW	S4	3/4	6466171-00		Idler Sheave	3
FEW	S4	5/8	6425776-00		Idler Sheave	3
FEW	S4	3/4	6424086-00		Idler Sheave	3
BEW	S4	5/16	5		6452031-16	Idler Sheave Shaft
BEW	S4	3/8		6452031-09	Idler Sheave Shaft	3
CEW	S4	3/8		6452031-16	Idler Sheave Shaft	3
CEW & DEW	S4	7/16 & 1/2		6452031-09	Idler Sheave Shaft	3
DEW & EEW	S4	5/8		6452031-12	Idler Sheave Shaft	3
EEW	S4	1/2		6452031-09	Idler Sheave Shaft	3
EEW	S4	3/4		6452031-15	Idler Sheave Shaft	3
FEW	S4	5/8		6444103-00	Idler Sheave Shaft	3
FEW	S4	3/4		6444103-00	Idler Sheave Shaft	3
BEW	S4	5/16		6	0151281-00	Idler Sheave Bearing
BEW	S4	3/8	6456668-00		Idler Sheave Bearing	3
CEW	S4	3/8	0151281-00		Idler Sheave Bearing	3
CEW & DEW	S4	7/16 & 1/2	6456668-00		Idler Sheave Bearing	3
DEW & EEW	S4	5/8	0100846-00		Idler Sheave Bearing	3
EEW	S4	1/2	6456668-00		Idler Sheave Bearing	3
EEW	S4	3/4	6441528-00		Idler Sheave Bearing	3
FEW	S4	5/8	6441528-00		Idler Sheave Bearing	3
FEW	S4	3/4	6441528-00		Idler Sheave Bearing	3
BEW	S4	5/16	7		5003439-14	Bearing Retainer
BEW	S4	3/8		5003439-02	Bearing Retainer	3
CEW	S4	3/8		5003439-14	Bearing Retainer	3
CEW & DEW	S4	7/16 & 1/2		5003439-02	Bearing Retainer	3
DEW & EEW	S4	5/8		5003439-11	Bearing Retainer	3
EEW	S4	1/2		5003439-02	Bearing Retainer	3
EEW	S4	3/4		6401619-02	Bearing Retainer	3
FEW	S4	5/8		6401619-02	Bearing Retainer	3
FEW	S4	3/4		6401619-02	Bearing Retainer	3

FORM NO. 165-903-110

**When Replacement Parts Are Needed, Order Only Yale® Factory Engineered Parts**

JUNE 1982

4

EW SERIES

D4 - REEVING TABLE

Chassis	Reev- ing	Rope Dia.	Item No.	Part Number	Description	Fig. No.
BEW & CEW	D4	1/4	1	0109892-00	Idler Sheave	4
CEW & DEW	D4	5/16 & 3/8		0616652-00	Idler Sheave	4
DEW	D4	7/16		0109996-00	Idler Sheave	4
EEW	D4	3/8 & 7/16		0109996-00	Idler Sheave	4
EEW	D4	1/2 & 9/16		6455711-00	Idler Sheave	4
FEW	D4	7/16 & 1/2		6487561-00	Idler Sheave	4
FEW	D4	9/16		6423126-00	Idler Sheave	4
BEW & CEW	D4	1/4	2	0151283-00	Sheave Bearing	4
CEW & DEW	D4	5/16 & 3/8		0100622-00	Sheave Bearing	4
DEW	D4	7/16		0274205-00	Sheave Bearing	4
EEW	D4	3/8 & 7/16		0274205-00	Sheave Bearing	4
EEW	D4	1/2 & 9/16		6401629-01	Sheave Bearing	4
FEW	D4	7/16 & 1/2		6401629-01	Sheave Bearing	4
FEW	D4	9/16		6401629-01	Sheave Bearing	4
BEW & CEW	D4	1/4	3	5003439-12	Bearing Retainer	4
CEW & DEW	D4	5/16 & 3/8		5003439-15	Bearing Retainer	4
DEW	D4	7/16		5003439-02	Bearing Retainer	4
EEW	D4	3/8 & 7/16		5003439-02	Bearing Retainer	4
EEW	D4	1/2 & 9/16		6401619-01	Bearing Retainer	4
FEW	D4	7/16 & 1/2		6401619-01	Bearing Retainer	4
FEW	D4	9/16		6401619-01	Bearing Retainer	4
BEW & CEW	D4	1/4	4	6475991-00	Idler Sheave Shaft	4
CEW & DEW	D4	5/16 & 3/8		6472811-00	Idler Sheave Shaft	4
DEW	D4	7/16		6469581-00	Idler Sheave Shaft	4
EEW	D4	3/8 & 7/16		6469581-00	Idler Sheave Shaft	4
EEW	D4	1/2 & 9/16		6473961-00	Idler Sheave Shaft	4
FEW	D4	7/16 & 1/2		6473961-00	Idler Sheave Shaft	4
FEW	D4	9/16		6473961-00	Idler Sheave Shaft	4
BEW & CEW	D4	1/4	5	6452041-06	Yoke	4
CEW & DEW	D4	5/16 & 3/8		6452041-08	Yoke	4
DEW	D4	7/16		6452041-09	Yoke	4
EEW	D4	3/8 & 7/16		6452041-09	Yoke	4
EEW	D4	1/2 & 9/16		6452041-12	Yoke	4
FEW	D4	7/16 & 1/2		6452041-12	Yoke	4
FEW	D4	9/16		6452041-12	Yoke	4
BEW & CEW	D4	1/4	6	6480741-00	Yoke Shaft	4
CEW & DEW	D4	5/16 & 3/8		6480751-00	Yoke Shaft	4
DEW	D4	7/16		6480731-00	Yoke Shaft	4
EEW	D4	3/8 & 7/16		6480731-00	Yoke Shaft	4
EEW	D4	1/2 & 9/16		6480721-00	Yoke Shaft	4
FEW	D4	7/16 & 1/2		6480721-00	Yoke Shaft	4
FEW	D4	9/16		6480721-00	Yoke Shaft	4
BEW & CEW	D4	1/4	7	6479081-00	Equalizer Sheave	4
CEW & DEW	D4	5/16 & 3/8		6457771-00	Equalizer Sheave	4
DEW	D4	7/16		6479071-00	Equalizer Sheave	4
EEW	D4	3/8 & 7/16		6479071-00	Equalizer Sheave	4
EEW	D4	1/2 & 9/16		6457761-00	Equalizer Sheave	4
FEW	D4	7/16 & 1/2		6457761-00	Equalizer Sheave	4
FEW	D4	9/16		6457761-00	Equalizer Sheave	4
BEW & CEW	D4	1/4	8	6454071-00	Equalizer Sheave Pin	4
CEW & DEW	D4	5/16 & 3/8		6454071-00	Equalizer Sheave Pin	4
DEW	D4	7/16		6452031-05	Equalizer Sheave Pin	4
EEW	D4	3/8 & 7/16		6452031-05	Equalizer Sheave Pin	4
EEW	D4	1/2 & 9/16		6452031-07	Equalizer Sheave Pin	4
FEW	D4	7/16 & 1/2		6452031-07	Equalizer Sheave Pin	4
FEW	D4	9/16		6452031-07	Equalizer Sheave Pin	4

When Replacement Parts Are Needed, Order Only Yale® Factory Engineered Parts



**SECTION 1630**  
**REEVING KIT**

**D6 - REEVING TABLE**

Chassis	Reev- ing	Rope Dia.	Item No.	Part Number	Description	Fig. No.
EEW FEW FEW	D6 D6 D6	7/16 - 1/2 1/2 9/16	1	6455711-00 6487561-00 6423126-00	Idler Sheave ..... Idler Sheave ..... Idler Sheave .....	4 4 4
EEW FEW FEW	D6 D6 D6	7/16 & 1/2 1/2 9/16	2	6401629-01 6401629-01 6401629-01	Sheave Bearing ..... Sheave Bearing ..... Sheave Bearing .....	4 4 4
EEW FEW FEW	D6 D6 D6	7/16 & 1/2 1/2 9/16	3	6401619-01 6401619-01 6401619-01	Bearing Retainer ..... Bearing Retainer ..... Bearing Retainer .....	4 4 4
EEW FEW FEW	D6 D6 D6	7/16 & 1/2 1/2 9/16	4	6473941-00 6473941-00 6473941-00	Idler Sheave Shaft ..... Idler Sheave Shaft ..... Idler Sheave Shaft .....	4 4 4
EEW FEW FEW	D6 D6 D6	7/16 & 1/2 1/2 9/16	5	6452021-02 6452021-02 6452021-02	Yoke ..... Yoke ..... Yoke .....	4 4 4
EEW FEW FEW	D6 D6 D6	7/16 & 1/2 1/2 9/16	6	6480711-00 6480711-00 6480711-00	Yoke Shell ..... Yoke Shell ..... Yoke Shell .....	4 4 4
EEW FEW FEW	D6 D6 D6	7/16 & 1/2 1/2 9/16	7	6457761-00 6457761-00 6457761-00	Equalizer Sheave ..... Equalizer Sheave ..... Equalizer Sheave .....	4 4 4
EEW FEW FEW	D6 D6 D6	7/16 & 1/2 1/2 9/16	8	6431891-00 6431891-00 6431891-00	Equalizer Sheave Pin ..... Equalizer Sheave Pin ..... Equalizer Sheave Pin .....	4 4 4

03-110-4  
FORM NO. 165-903-110

**When Replacement Parts Are Needed, Order Only Yale® Factory Engineered Parts**

JUNE 1982

6

EW SERIES



**BOTTOM BLOCK REPAIR PARTS**

**SECTION 1640  
BOTTOM BLOCK**

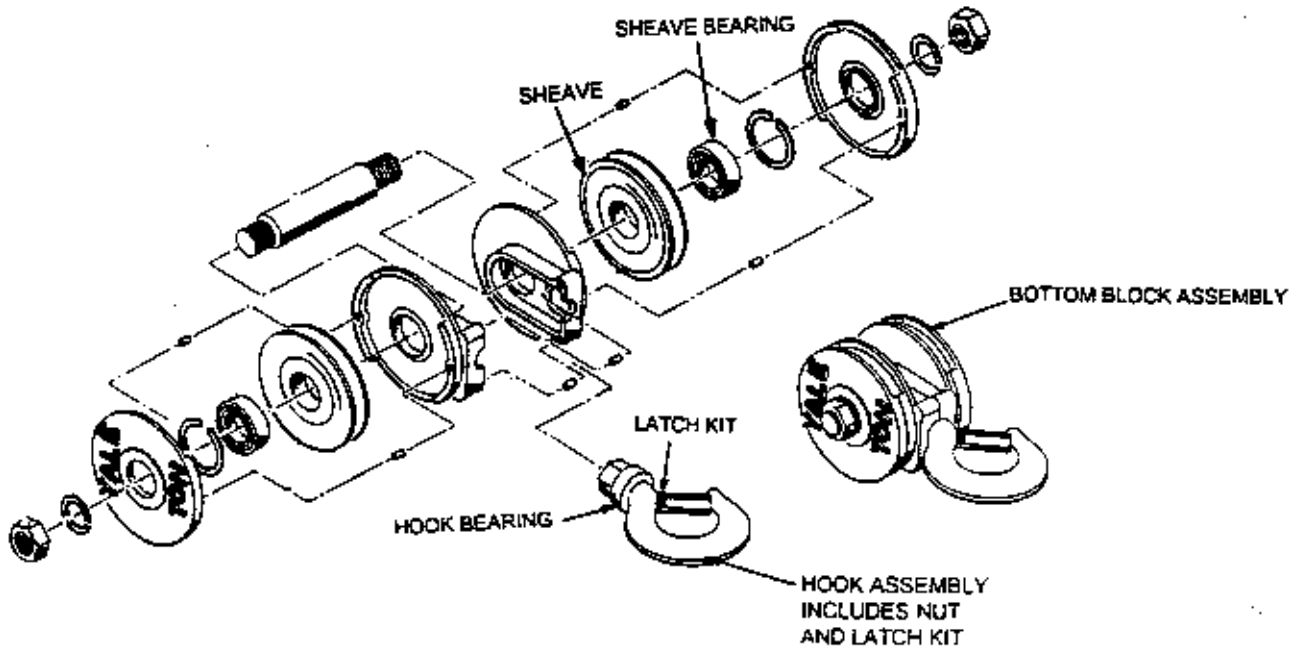

**NOTE:**  
THE BOTTOM BLOCK ILLUSTRATED ABOVE MAY NOT EXACTLY REPRESENT THE ACTUAL APPEARANCE OF YOUR BOTTOM BLOCK. HOWEVER, IT IS TYPICAL.

**NOTE:**  
FOR REPLACEMENT, SEE PARTS LIST IN FRONT OF PARTS MANUAL. FOR PARTS NOT LISTED CONTACT THE FACTORY.







**When Replacement Parts Are Needed, Order Only YALE Factory Engineered Parts**

## **SECTION 2300 CONTROL COMPONENTS**

### **To Select Control Components or Repair Parts**

- (1) Refer to parts list in front cover of manual for component part numbers. The illustrations and descriptions in this section can be used to assist in component identification.
- (2) If complete device is needed, order by part number from the parts list.
- (3) If repair parts are needed locate the control components on parts lists, in front of manual. The repair parts are listed for that device. If the component is not shown or the part you need is not listed, order the complete device or request assistance from your Yale dealer or repair station.

## SECTION 2310 & 15 CONTACTOR

	COIL VOLTAGE	CONTACTOR PART NO.	COIL PART NO.	CONTACT KIT	AUXILIARY CONTACT
	24	6401559-01	5030618-00	6409198-00	6446608-01(N.O.)
	115	6401559-02	5030628-00		6446608-02 (N.C)
	24	6480364-01	6480304-01	N/A	6480304-21(N.O.)
	115	6480364-02	6480304-02		6480304-20 (N.C)
	24	6480374-01	6480304-01	N/A	6480304-21(N.O.)
	115	6480374-02	6480304-02		6480304-20 (N.C)
	24	6480384-01	6480304-11	6480304-31	6480304-21(N.O.)
	115	6480384-02	6480304-12		6480304-20 (N.C)
	24	6480334-01	6480304-01	N/A	6480304-21(N.O.)
	115	6480334-02	6480304-02		6480304-20 (N.C)
	24	6480344-01	6480304-11	6480304-31	6480304-21(N.O.)
	115	6480344-02	6480304-12		6480304-20 (N.C)

Form No. 165-909-027

**When Replacement Parts Are Needed, Order Only YALE<sup>®</sup> Factory Engineered Part**

REVISED AUGUST 1995

Authorized Sales & Service - McLaughlin Hoist & Crane - For Parts or Service Call (636) 343-9700

EW SERIES

# Duff-Norton Yale® Hoists

## SECTION 2330 TRANSFORMER

TRANSFORMER NINE DIGIT PART NUMBER STAMPED HERE

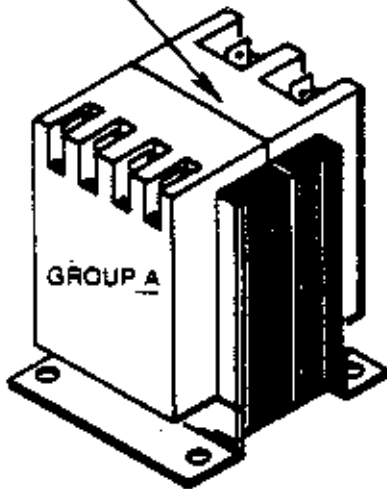

1. FIND VA, PRIMARY & SECONDARY VOLTS.
2. USE PARTS LIST IN FRONT COVER OR CHART TO SELECT TRANSFORMER

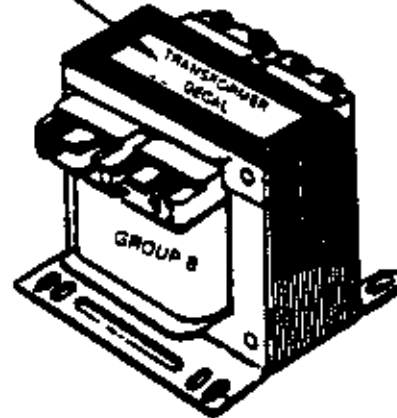

**GROUP A**

VA	Primary Volts	Secondary Volts	Hertz	Part Number	Fuse Required
25	115/230	24	50/60	6437393-01	N/R
	230/460	24	50/60	6437393-02	N/R
	115/230	110	50/60	6437393-03	N/R
	230/460	110	50/60	6437393-04	N/R
	200	24	50/60	6437393-05	N/R
	200	110	50/60	6437393-06	N/R
	575	24	50/60	6437393-07	N/R
	575	110	50/60	6437393-08	N/R

**GROUP B**

50	200	115	50/60	6478963-12	6458398-04
	230/460	115	50/60	6478963-13	6458398-04
	575	115	50/60	6478963-14	6458398-04
	200	24	50/60	6478963-15	6458398-11
	230/460	24	50/60	6478963-17	6458398-11
	575	24	50/60	6478963-18	6458398-11
150	200	115	50/60	6478963-22	6458398-08
	230/460	115	50/60	6478963-23	6458398-08
	575	115	50/60	6478963-24	6458398-08
	200	24	50/60	6478963-26	6458398-20
	230/460	24	50/60	6478963-27	6458398-20
	575	24	50/60	6478963-28	6458398-20
300	200	115	50/60	6478963-32	6458398-12
	230/460	115	50/60	6478963-33	6458398-12
	575	115	50/60	6478963-34	6458398-12
	200	24	50/60	6478963-36	6458398-25
	230/460	24	50/60	6478963-37	6458398-25
	575	24	50/60	6478963-38	6458398-25

N/R NOT REQUIRED

**When Replacement Parts Are Needed, Order Only Yale® Factory Engineered Parts**

# Yale Hoisting Equipment

## SECTION 2345

## THERMAL OVERLOAD HEATERS

## EW SERIES THERMAL OVERLOAD HEATERS

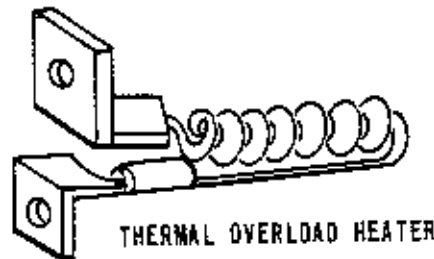

The Overload Heater Illustrated Above  
May Not Exactly Represent The Actual  
Appearance Of Your Overload Heater.  
However, It Is Typical.

Manufacturers Identification	Part Number	Full Load Amp Rating When Used In Overload Relay Number			
		6452508-00 (SEO-6B2) (3 Pole) Rating	6481811-01 (SEO-9B2) (3 Pole) Rating	0106755-00 0106756-00 (ARO-1) (1 Pole) Rating	(ATO-1) (1 Pole) Rating
AR .71	6400789-01	.52—.56		.56—.60	
AR .78	6400789-04	.57—.62		.61—.66	
AR 1.05	6400789-03	.77—.84		.82—.89	
AR 1.15	0579103-00	.85—.92		.90—.98	
AR 1.26	0106784-00	.93—1.01		.99—1.08	
AR 1.39	6400789-07	1.02—1.12		1.09—1.19	
AR 1.53	0106775-00	1.13—1.23		1.20—1.31	
AR 1.68		1.24—1.35		1.32—1.45	
AR 1.85	0106772-00	1.36—1.50		1.46—1.60	
AR 2.04	0106787-00	1.51—1.65		1.61—1.76	
AR 2.24	0106776-00	1.66—1.81		1.77—1.93	
AR 2.46	6400789-02	1.82—1.99		1.94—2.13	
AR 2.71	0106782-00	2.00—2.19		2.14—2.34	
AR 2.98	0546128-00	2.20—2.41		2.35—2.58	
AR 3.28	0106770-00	2.42—2.67		2.59—2.85	
AR 3.62	0106778-00	2.68—2.93		2.86—3.13	
AR 3.98	6400789-06	2.94—3.22		3.14—3.44	
AR 4.37	0580153-00	3.23—3.54		3.45—3.78	

FORM NO. 165-909-013

**When Replacement Parts Are Needed, Order Only Yale® Factory Engineered Parts**

AUGUST 1983

EW SERIES

**SECTION 2345**  
**THERMAL OVERLOAD HEATERS**

Manufacturers Identification	Part Number	Full Load Amp Rating When Used In Overload Relay Number			
		6452508-00 (SEO-6B2) (3 Pole) Rating	6481811-01 (SEO-9B2) (3 Pole) Rating	0106755-00 0106756-00 (ARO-1) (1 Pole) Rating	(ATO-1) (1 Pole) Rating
AR 4.80	6400789-05	3.55-3.91		3.79-4.17	
AR 5.3	0106783-00	3.92-4.28		4.18-4.57	
AR 5.8	0106771-00	4.29-4.72		4.58-5.04	
AR 6.4	0586636-00	4.73-5.17		5.05-5.52	
AR 7.0	0106779-00	5.18-5.68		5.53-6.07	
AR 7.7	0106762-00	5.69-6.28		6.08-6.70	
AR 8.5	0106768-00	6.29-6.87		6.71-7.33	
AR 9.3	0106769-00	6.88-7.54	5.11-5.60	7.34-8.05	7.34-8.05
AR 10.2	0106767-00	7.55-8.28	5.61-6.15	8.06-8.84	8.06-8.84
AR 11.2	0106781-00	6.29-9.16	6.16-6.81	8.85-9.78	8.85-9.78
AR 12.4	0106774-00	9.17-9.99	6.82-7.47	9.79-10.6	9.79-10.6
AR 13.6	0106766-00	10.0-11.3	7.48-8.47	10.7-12.0	10.7-12.0
AR 15.4	0106785-00	11.4-12.9	8.47-9.67	12.1-13.8	12.1-13.8
AR 17.6	0106763-00	13.0-15.1	9.68-11.2	13.9-16.1	13.9-16.1
AR 20.5	0106777-00	15.2-16.9	11.3-12.5	15.2-18.1	15.2-18.1
AR 23.	0106764-00	17.0-19.9	12.6-14.8	18.2-21.2	18.2-21.2
AR 27.	0106765-00	20.0-22.1	14.9-16.4	21.3-23.6	21.3-23.6
AR 30.	0106768-00	22.2-24.8	16.5-19.1	23.7-27.5	23.7-27.5
AR 35.	0106780-00	25.9-28.5	19.2-21.9	27.6-31.5	27.6-31.5
AR 40.	0547894-00	29.6-31.5	22.0-23.1		31.6-33.6
AR 44.	6466548-00		24.2-25.7		34.7-37.0
AR 47.			25.8-27.9		37.1-40.2
AR 51.	0548711-00		28.0-30.1		40.3-43.3
AR 55.	0594821-00		30.2-32.9		43.4-47.3
AR 60.			33.0-36.2		47.4-52.0
AR 66.			36.3-39.5		
AR 72.			39.6-43.3		
AR 79.			43.4-47.2		
AR 86.			47.3-51.6		
AR 94.			51.7-55.0		

NO.09-013

FORM NO. 165-909-013

**When Replacement Parts Are Needed, Order Only Yale® Factory Engineered Parts**

EW SERIES

AUGUST 1983









**SECTION 2700****PUSH BUTTONS****To Select Push Button Stations Or Components**

- (1) Refer to parts list in front cover of manual for station or component numbers.
- (2) For Section 2710 stations, refer parts request to Yale dealer or repair station. Specify hoist model and serial numbers, push button station part number from parts list, and a complete description of the parts needed.
- (3) For Section 2740 thru 2760 components, order by part number from the parts list. The illustrations and descriptions in this section can be used to assist in component identification.



**SECTION 2710 / 80**

**PUSH BUTTON**



2740		Enclosure (Less) (Elements)	Two Button Four Button Six Button Eight Button Ten Button	6452753-02 6452753-04 6452753-06 6452753-08 6452753-10
2750		Elements	Single Speed (Pair)	6452763-01
	Two Speed (Pair)		6452763-02	
	Five Speed (Pair)		6452763-05	
	Maintained/ Momentary		6455953-00	
		Selector Switch	Two Position Three Position	6463493-00 6455983-00
		Pilot Light	115 Volt Red	6455973-00
		Potentiometer	1000 Ohm	6451821-01
		Elements	Single Button (One)	6456263-00
	Off/On Element	Locking Non-Locking	6455963-00	
	Closing Plate		6452883-00	

JULY 1983

**SECTION 2710 / 80**

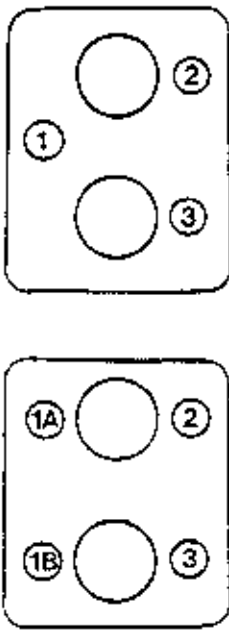
**PUSH BUTTON**

2760 	Component Number	Markings				
		1	1A	1B	2	3
	6452803-01	Hoist			Up	Down
	6452803-02	Trolley			East	West
	6452803-03	Trolley			Forward	Reverse
	6452803-04	Trolley			North	South
	6452803-05	Bridge			Foward	Reverse
	6452803-06	Bridge			East	West
	6452803-07	Bridge			North	South
	6452803-08				Start	Stop
	6452803-09				Reset	Stop
	6452803-10					
	6452803-11				Foward	Reverse
	6452803-12				North	South
	6452803-13				East	West
	6452803-14				In	Out
	6452803-15				Left	Right
	6452803-16	Crane			Forward	Reverse
	6452803-17				Off	On
	6452803-18				On	Off
	6452803-19				Stop	Start
	6452803-20				Stop	Reset
	6452803-21			Inch		Run
	6452803-22			Slow		Fast

2710		Complete Station	Two Button	Up-Down	6480701-01
			S / Speed	Fwd- Rev	6480701-02
			Two Button	Up-Down	6469823-01
			Two Speed	Fwd-Rev	6469823-02
2710		COMPLETE STATION	TWO BUTTON S/SPEED	6471993-00	
2710		For Explosion Proof or other Special Push Buttons, Refer to Computer Parts list in front of Manual.			

# Yale Hoisting Equipment

**SECTION 3215 / 16**  
**TROLLEY IDLER GEAR**

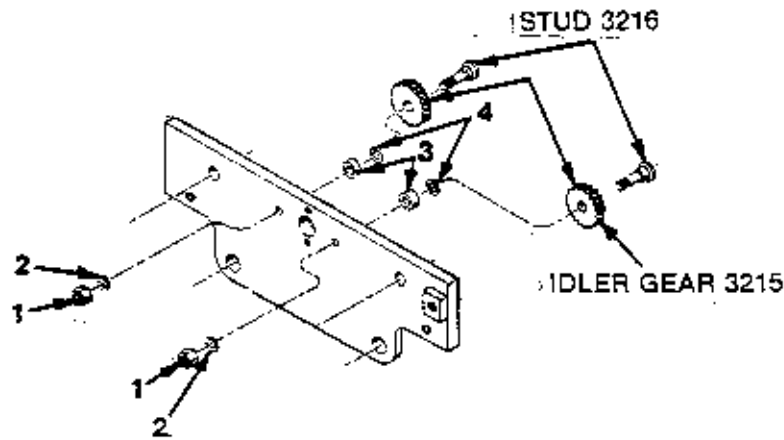

GEAR	STUD	ITEM 1 NUT	ITEM 2 LOCKWASHER	ITEM 3 SPACER	ITEM 4 WASHER
<b>STANDARD</b>					
0664821-00	0664826-00	0149375-00	0401008-00	6400821-00	0250699-00
0664432-00	6400811-00	0149374-00	0150268-00	0544159-00	0143734-00
6456801-00	6400811-00	0149374-00	0150268-00	0544158-00	0143734-00
<b>BRONZE</b>					
6490241-00	0664826-00	0149375-00	0401008-00	6400821-00	0250699-00
6421663-00	6400811-00	0149374-00	0150268-00	0544158-00	0143734-00
6487501-00	6400811-00	0149374-00	0150268-00	0544158-00	0143734-00

FORM NO. 165-912-117

**When Replacement Parts Are Needed, Order Only Yale® Factory Engineered Parts**

JULY 1983

1

EW SERIES

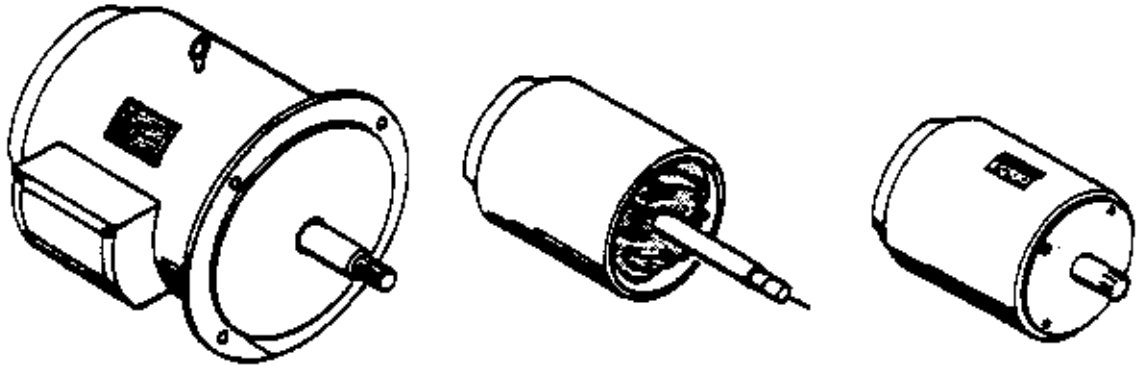
**SECTION 3310  
TROLLEY MOTOR**

For Part Number Of Complete Motor, Refer To Parts List In Front Of Manual. Part Number May Also Be Found On Motor Nameplate.

If Individual Motor Parts Are Required, Specify Motor Part Number, Motor Model And Serial Numbers From The Motor Nameplate, Hoist Or Trolley Model And Serial numbers From The Hoist Or Trolley Nameplate, And A Complete Description Of The Items Needed.

# Yale Hoisting Equipment

USER INFORMATION PAGE

**IMPORTANT**  
SELECT COMPONENT ASSEMBLY  
NUMBER FROM PARTS LIST IN FRONT  
COVER BEFORE SELECTING  
REPLACEMENT ITEM NUMBER

1. FIND TWO DIGIT IDENTIFICATION CODE STAMPED ON TOP OF THE TROLLEY GEARCASE.

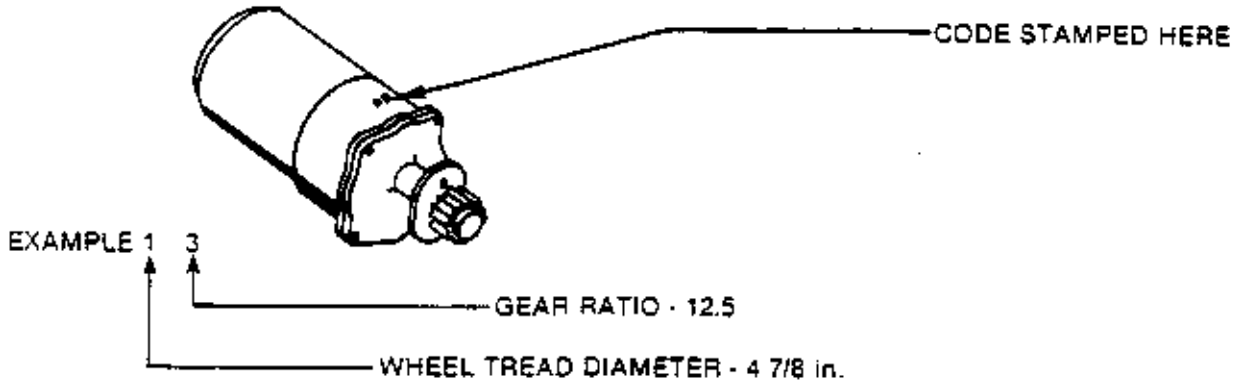

2. SEE TABLE BELOW FOR TROLLEY SPEED AND REPAIR PARTS PAGE NUMBER.

3. TURN TO SECTION 3320 PAGES 2, 3 & 4 FOR REPAIR PART INFORMATION

NOTE: CATALOG SPEEDS ARE BASED ON 1800 RPM MOTORS.

Complete ST Gearing Assembly							
Standard EW Selection	Exp. Proof EW Selection	Standard AW Selection	Two Digit Code	Tread Diameter (in.)	Gear Ratio	Trolley Speed	Section Page No.
5460072-11	6462142-11	6459472-11	11	4 7/8	18.06	25	3320 Page 4
5460072-12	6462142-12	6459472-12	12	4 7/8	13.58	30	
5460072-13	6462142-13	6459472-13	13	4 7/8	12.5	35	
5460072-14	6462142-14	6459472-14	14	4 7/8	9.4	50	
5460072-15	6462142-15	6459472-15	15	4 7/8	7.87	55	
5460072-16	6462142-16	6459472-16	16	4 7/8	5.45	70	
5460072-21	6462142-21	6459472-21	21	6	18.06	35	3320 Page 4
5460072-22	6462142-22	6459472-22	22	6	13.58	50	
5460072-23	6462142-23	6459472-23	23	6	12.5	55	
5460072-24	6462142-24	6459472-24	24	6	9.4	70	
5460072-25	6462142-25	6459472-25	25	6	7.87	80	
5460072-26	6462142-26	6459472-26	26	6	5.45	120	
5460072-31	6462142-31	6459472-31	31	8	18.06	35	3320 Page 4
5460072-32	6462142-32	6459472-32	32	8	13.58	45	
5460072-33	6462142-33	6459472-33	33	8	12.5	50	
5460072-34	6462142-34	6459472-34	34	8	9.4	70	
5460072-35	6462142-35	6459472-35	35	8	7.87	80	
5460072-36	6462142-36	6459472-36	36	8	5.45	115	
5460072-41	6462142-41	6459472-41	41	10	18.06	35	3320 Page 4
5460072-42	6462142-42	6459472-42	42	10	13.58	45	
5460072-43	6462142-43	6459472-43	43	10	12.5	50	
5460072-44	6462142-44	6459472-44	44	10	9.4	70	
5460072-45	6462142-45	6459472-45	45	10	7.87	80	
5460072-46	6462142-46	6459472-46	46	10	5.45	115	

\* C-Face Mounting

FORM NO. 165-912-113

**When Replacement Parts Are Needed, Order Only Yale® Factory Engineered Parts**

REV JULY 1983

EW / AW SERIES

**SECTION 3320**  
**GEARING**  
**ST SERIES**

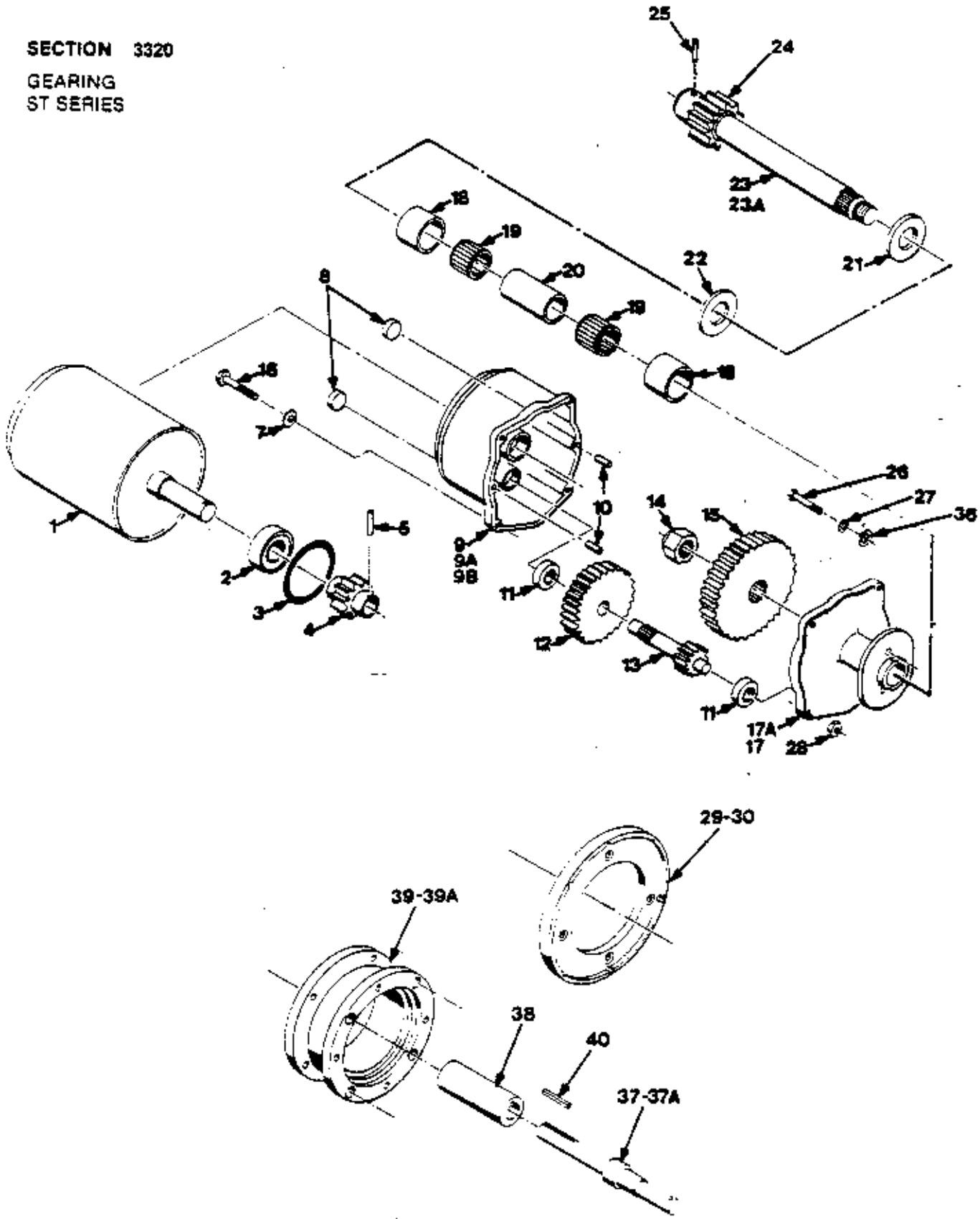

FORM NO. 165-912-115

**When Replacement Parts Are Needed, Order Only Yale® Factory Engineered Parts**

EW / AW SERIES

JULY 1983

ITEM	PART NO.	DESCRIPTION	QTY.
1	SEE PARTS LIST	MOTOR	1
2	0325737-00	MOTOR BEARING	1
3	0193248-00	"O" RING	1
4	SEE TABLE 2	PINION	1
5	SEE TABLE 2	PINION PIN	1
6	0146723-00	SCREW (CONTROL BOX MTG. ONLY)	2
7	0150264-00	WASHER	4
8	0230825-00	PIPE PLUG	2
9	0192483-00	GEARCASE FOR PARTIAL MOTOR	1
9A	5041364-00	GEARCASE FOR C-FACE MOTOR	1
9B	6499941-00	GEARCASE AIR POWERED	1
10	6400529-01	DOWEL PIN	2
11	0100850-00	BEARING	2
12	SEE TABLE 2	GEAR	1
13	SEE TABLE 2	PINION	1
14	0326590-00	LOCKNUT 5/8 - 11	1
15	SEE TABLE 2	GEAR	1
16	0570482-00	SCREW 3/8 - 16 x 1	4
17	0221092-00	GEARCASE COVER STANDARD	1
17A	6448581-00	GEARCASE COVER C-FACE & AIR POWERED	1
18	0610994-00	INNER RACE	2
19	0572813-00	NEEDLE BEARING	2
20	0317344-00	SPACER	1
21	0535816-00	WASHER	1
22	0544158-00	WASHER, THRUST BRONZE SELF LUB.	1
23	SEE TABLE 1	SHAFT	1
23A	6400851-00	PINION & SHAFT ASM. (4 7/8 WHL TREAD DIA. ONLY)	1
24	SEE TABLE 1	PINION	1
25	SEE TABLE 1	DRIVE PIN	1
26	0554850-00	SCREW 1/2 - 13 x 1 1/4	2
27	0150266-00	LOCKWASHER	2
28	0149369-00	NUT 3/8 - 16	2
29	5039344-00	ADAPTER (C-FACE MOTOR)	1
30	5039354-00	ADAPTER (GEARCASE) (C-FACE MOTOR)	1
31	0149087-00	SCREW 5/16 X 1 FLAT HD (NOT SHOWN)	4
32	0149100-00	SCREW 3/8 X 7/8 FLAT HD (NOT SHOWN)	4
33	0597191-00	SCREW 3/8 - 1 1/2 (NOT SHOWN)	4
34	0150264-00	3/8 LOCKWASHER (NOT SHOWN)	12
35	0597164-00	SCREW 5/16 X 2 1/4 (NOT SHOWN)	4
36	0161100-00	FLAT WASHER	2
37	6489361-00	PINION SHAFT (W/HORTON BRK.) AIR POWERED	1
37A	6447193-00	PINION SHAFT (W/O BRAKE) AIR POWERED	1
38	6447203-00	COUPLING (W/O BRAKE) AIR POWERED	1
39	6447213-00	ADAPTER (W/O BRAKE) AIR POWERED	1
39A	6489391-00	ADAPTER (W/HORTON BRAKE) AIR POWERED	1
40	6405431-00	KEY, DRIVE SHAFT AIR POWERED	2
41	0621437-00	SCREW 5/16 X 1 (NOT SHOWN) AIR POWERED	4
42	0150262-00	LOCKWASHER 5/16 (NOT SHOWN) AIR POWERED	4
43	0570482-00	SCREW 3/8 X 1 (NOT SHOWN) AIR POWERED	8

FORM NO. 165-912-115

**When Replacement Parts Are Needed, Order Only Yale® Factory Engineered Parts**

REV. JULY 1983

3

EW / AW SERIES

**SECTION 3320****GEARING  
ST SERIES****TABLE 1**

	PINION SHAFT ITEM 23	PINION ITEM 24	DRIVE PIN ITEM 25
6 in. Whl Trolley	6401423-00	0588168-00 14 teeth	0559292-00
8 in. Whl Trolley	6435181-00	6415121-00 10 teeth	0157393-00
10 in. Whl Trolley	6426333-00	6415121-00 10 teeth	0157393-00

**TABLE 2**

TWO DIGIT CODE	WHEEL TREAD DIA.			MOTOR PINION ITEM 4	LOCK PIN ITEM 5	GEAR ITEM 12	PINION ITEM 13	GEAR ITEM 15
	4 7/8	6	8 & 10					
	SPEED FPM							
11	25	-	-	0104607-00 12 teeth	0106959-00	6407531-00 52 teeth	6407511-00 12 teeth	0226396-00 50 teeth
12	30	-	-	0104607-00 12 teeth	0106959-00	6407531-00 52 teeth	6407501-00 15 teeth	0226408-00 47 teeth
13	35	-	-	0104602-00 16 teeth	0106953-00	6407541-00 48 teeth	6407511-00 12 teeth	0226396-00 50 teeth
14	50	-	-	0104602-00 16 teeth	0106953-00	6407541-00 48 teeth	6407501-00 15 teeth	0226408-00 47 teeth
15	55	-	-	0104607-00 12 teeth	0106959-00	6407531-00 52 teeth	6407521-00 22 teeth	0610986-00 40 teeth
16	70	-	-	0104602-00 16 teeth	0106953-00	6407541-00 48 teeth	6407521-00 22 teeth	0610986-00 40 teeth
21, 31, 41	-	35	35	0104607-00 12 teeth	0106959-00	6407531-00 52 teeth	6407511-00 12 teeth	0226396-00 50 teeth
22, 32, 42	-	50	45	0104607-00 12 teeth	0106959-00	6407531-00 52 teeth	6407501-00 15 teeth	0226408-00 47 teeth
23, 33, 43	-	55	50	0104602-00 16 teeth	0106953-00	6407541-00 45 teeth	6407511-00 12 teeth	0226396-00 50 teeth
24, 34, 44	-	70	70	0104602-00 16 teeth	0106953-00	6407541-00 48 teeth	6407501-00 15 teeth	0226408-00 47 teeth
25, 35, 45	-	80	80	0104607-00 12 teeth	0106959-00	6407531-00 52 teeth	6407521-00 22 teeth	0610986-00 40 teeth
26, 36, 46	-	120	115	0104602-00 16 teeth	0106953-00	6407541-00 48 teeth	6407521-00 22 teeth	0610986-00 40 teeth

-115-3

FORM NO. 165-912-115

**When Replacement Parts Are Needed, Order Only Yale® Factory Engineered Parts**

EW / AW SERIES

4

REV. JULY, 1983



# Yale Hoisting Equipment

SECTION 3323

**REPAIR PARTS**

**MOTORIZED TROLLEY DRIVE (RT)**

**Trolley Assembly**

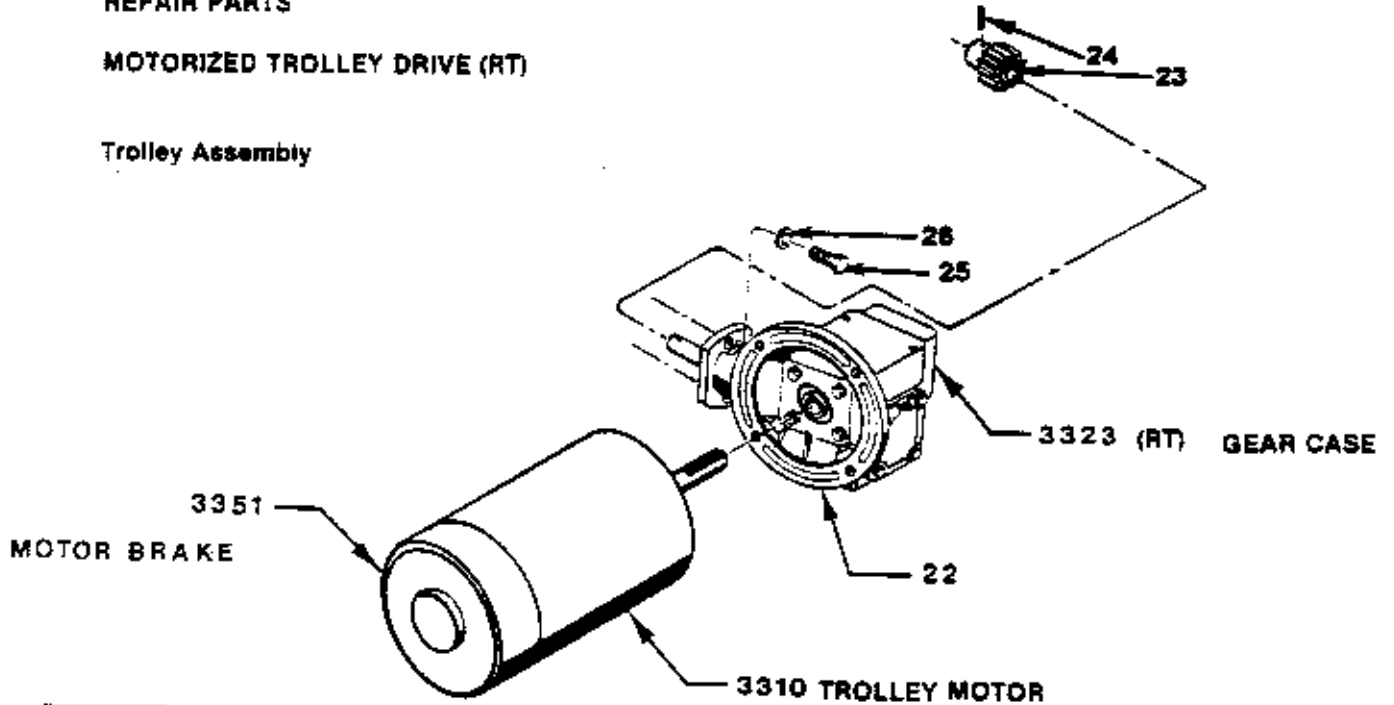

ITEM NBR.	PART NUMBER	DESCRIPTION	QTY.
3323	SEE PART LIST	GEAR CASE	1
3232	SEE PART LIST	RT MGT. KIT (Incl. Items 23, 24, 25 & 26)	1
22	8498053	ADAPTOR RING	1
23		PINION	1
24		GROOVE PIN	1
25		BOLT	1
26		LOCK WASHER	2
3310	SEE PART LIST*	MOTOR	2
3351	SEE PART LIST	MOTOR BRAKE	1

\* When Ordering Motors Give Complete Data on Motor Nameplate.

PAT-005

**When Replacement Parts Are Needed, Order Only Yale® Factory Engineered Parts**

AUGUST 1987

EW SERIES

## REPAIR PARTS

### MOTORIZED TROLLEY DRIVE (RT)

TROLLEY GEAR BOX  
133 and 175 SERIES

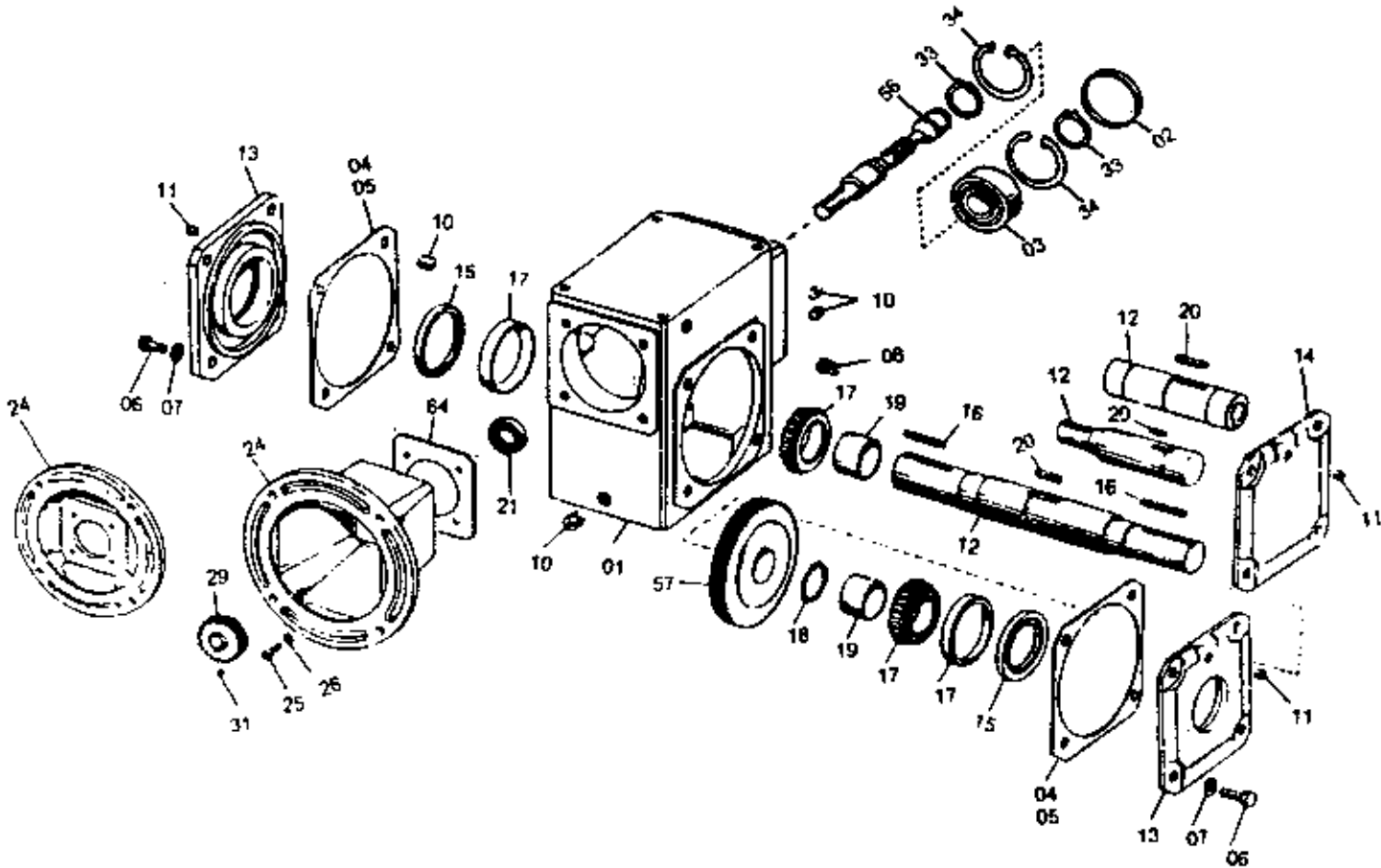

**\*\*NOTE** When ordering parts give complete name plate data.  
\*Refer to parts list in front of manual for gear box part number.

**When Replacement Parts Are Needed, Order Only Yale® Factory Engineered Parts**

OCTOBER 1994

EW SERIES

**Yale® Hoists**

**RT GEAR BOX**

<b>6462923** Series 133</b>	
ITEM **	DESCRIPTION
6444426-01	HOUSING
6444426-02	END COVER
6444426-03	BEARING
6444426-04	SHIM (.019 THICK)
6444426-05	SHIM (.007 THICK)
6444426-06	CAPSCREW
6444426-07	LOCKWASHER
6444426-09	VENT PLUG
6444426-10	PIPE PLUG
6444426-11	PIPE PLUG
6444426-12	OUTPUT SHAFT
6444426-13	SEAL CAGE
6444426-14	END COVER
6444426-15	OIL SEAL
6444426-16	KEY
6444426-17	BEARING
6444426-18	LOCK RING
6444426-19	SPACER
6444426-20	KEY
6444426-21	OIL SEAL
6444426-22	KEY
6444426-24	MOTOR FLANGE
6444426-25	CAPSCREW
6444426-26	LOCKWASHER
6444426-30	COUPLING HUB (MOTOR)
6444426-31	SETSCREW
6444426-33	LOCK RING
6444426-34	LOCK RING
** -56	WORM - SEE CHART
** -57	GEAR - SEE CHART
6444426-64	GASKET
NOTE: WHEN ORDERING REPLACEMENT PARTS, SPECIFY I.D. NUMBER, ITEM NUMBER AND PART DESCRIPTION.	

**Worm & Gear**

Ratio	Worm No.	Gear No.
5-1	6444706-01	6444706-02
10-1	6444706-03	6444706-04
15-1	6444706-05	6444706-06
20-1	6444706-07	6444706-08
30-1	6444706-09	6444706-10
40-1	6444706-11	6444706-12
50-1	6444706-13	6444706-14
60-1	6444706-15	6444706-16

When Replacement Parts Are Needed, Order Only Yale® Factory Engineered Parts

Yale® Hoists

**RT GEAR BOX**

6467093** Series 175	
ITEM **	DESCRIPTION
6449826-01	HOUSING
6449826-02	END COVER
6449826-03	BEARING
6449826-04	SHIM (.019 THICK)
6449826-05	SHIM (.007 THICK)
6449826-06	CAPSCREW
6444426-07	LOCKWASHER
6444426-09	VENT PLUG
6444426-10	PIPE PLUG
6444426-11	PIPE PLUG
6449826-12	OUTPUT SHAFT
6449826-13	SEAL CAGE
6449826-14	END COVER
6449826-15	OIL SEAL
6444426-16	KEY
6449826-17	BEARING
6449826-18	LOCK RING
6449826-19	SPACER
6449826-20	KEY
6444426-21	OIL SEAL
6444426-24	MOTOR FLANGE
6449826-25	CAPSCREW
6449826-26	LOCKWASHER
6449826-30	COUPLING HUB (MOTOR)
6449826-31	SETSCREW
6449826-33	LOCK RING
6449826-34	LOCK RING
** -56	WORM - SEE CHART
** -57	GEAR - SEE CHART
6444426-64	GASKET

NOTE: WHEN ORDERING REPLACEMENT PARTS, SPECIFY I.D. NUMBER, ITEM NUMBER AND PART DESCRIPTION.

Worm & Gear

RATIO	WORM NO.	GEAR NO.
5-1	# 645174601	# 645174602
10-1	# 645174603	# 645174604
15-1	# 645174605	# 645174606
20-1	# 645174607	# 645174608
30-1	# 645174609	# 645174610
40-1	# 645174611	# 645174612
50-1	# 645174613	# 645174614
60-1	# 645174615	# 645174616

# Yale Hoisting Equipment

## SECTION 3325

### DRIVE UNITS PARTS TR SERIES

ASSEMBLY NO.	GEAR RATIO
<input type="checkbox"/> 6442542-01	24.6
<input type="checkbox"/> 6442542-02	30.2
<input type="checkbox"/> 6442542-03	61.3
<input type="checkbox"/> 6442542-04	75.2

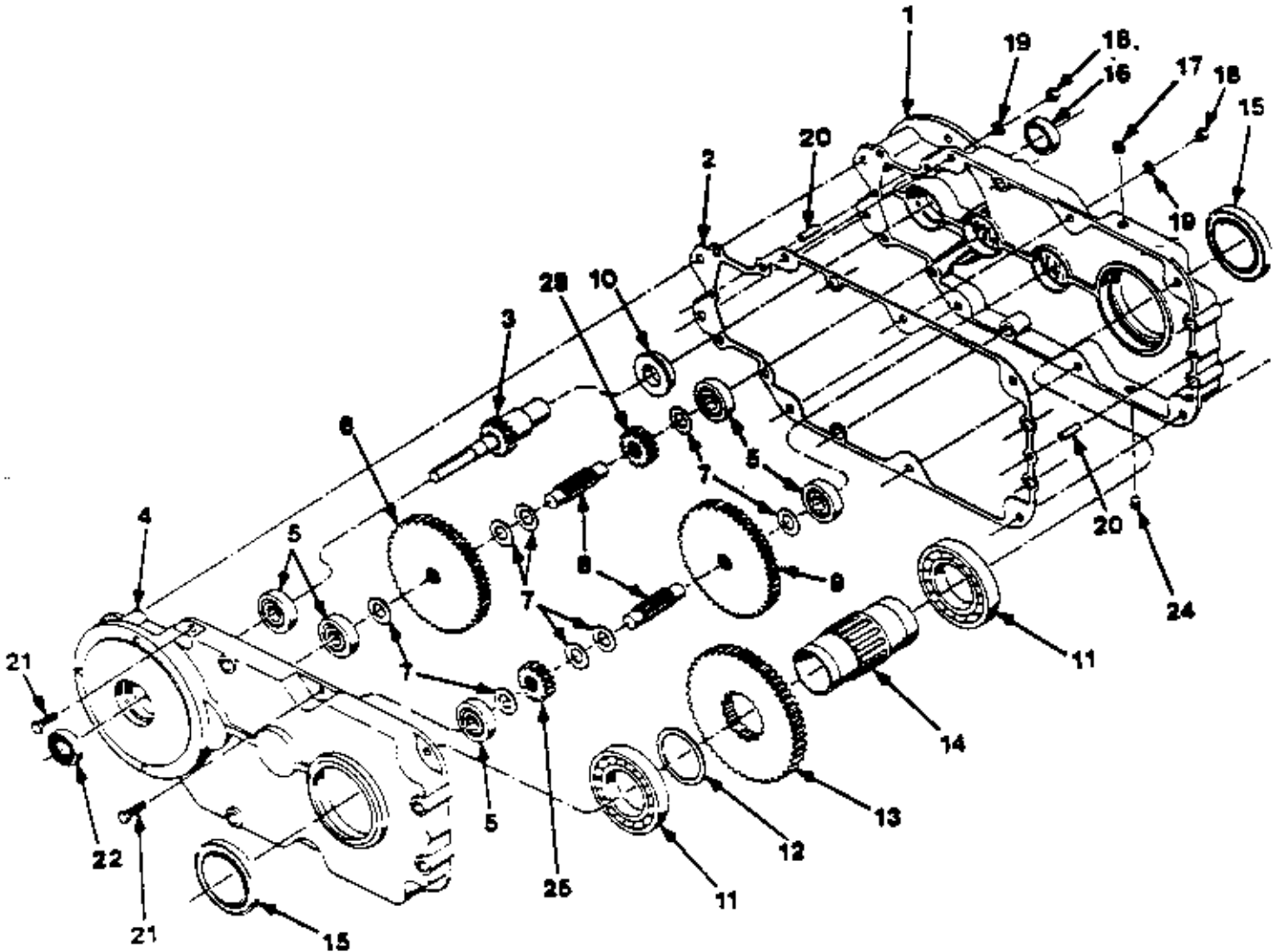

FORM NO. 165-912-107

**When Replacement Parts Are Needed, Order Only Yale® Factory Engineered Parts**

DEC. 91

TR SERIES

**DRIVE UNITS PARTS  
TR SERIES**

**Section 5325**

ITEM	PART NO.	DESCRIPTION	QTY.
1	6470471-00	GEARCASE (MOTOR SIDE) .....	1
2	6470551-00	GASKET .....	1
3	SEE TABLE	INPUT PINION ASSEMBLY .....	1
4	6470481-00	GEARCASE (BRAKE SIDE) .....	1
5	6433178-00	BALL BEARING .....	5
6	SEE TABLE	HIGH SPEED GEAR .....	1
7	6419381-00	SPACER .....	8
8	6470431-00	SHAFT .....	2
9	SEE TABLE	INTERMEDIATE GEAR .....	1
10	6470421-00	BUSHING .....	1
11	5005059-05	BEARING .....	2
12	6470501-01	SPACER .....	1
13	6470461-00	OUTPUT GEAR .....	1
14	6470491-00	OUTPUT SHAFT .....	1
15	6470591-00	SEAL (OUTPUT SHAFT) .....	2
16	0277732-00	SEAL (MOTOR SIDE) .....	1
17	6472111-00	VENT PLUG .....	1
18	0149369-00	HEX NUT (3/8 - 16) .....	8
19	0150264-00	LOCKWASHER (3/8 MED.) .....	8
20	0238068-00	DOWEL PIN .....	2
21	0570482-00	SCREW (3/8 - 16) .....	8
22	6470581-00	SEAL (BRAKE SIDE) .....	1
23	SEE TABLE	INTERMEDIATE GEAR .....	1
24	5021179-03	DRAIN PLUG .....	3
25	6470451-01	INTERMEDIATE PINION .....	1

**GEARING TABLE - TR DRIVE UNITS**

TOTAL GEAR RATIO	DRIVE PINION (ITEM 3)	HIGH SPEED GEAR (ITEM 6)	INTERM. PINION (ITEM 23)	INTERM. GEAR (ITEM 9)
24.6	6485041-02 34 Teeth	6470441-02 70 Teeth	6470451-02 21 Teeth	6470451-03 58 Teeth
30.2	6485041-02 34 Teeth	6470441-02 70 Teeth	6470451-01 18 Teeth	6470451-04 61 Teeth
61.3	6485041-01 17 Teeth	6470441-01 87 Teeth	6470451-02 21 Teeth	6470451-03 58 Teeth
75.2	6485041-01 17 Teeth	6470441-01 87 Teeth	6470451-01 18 Teeth	6470451-04 61 Teeth

FORM NO. 185-912-107

**When Replacement Parts Are Needed, Order Only Yale® Factory Engineered Parts**  
TR SERIES

# Yale Hoisting Equipment

## TROLLEY ASSEMBLY PARTS

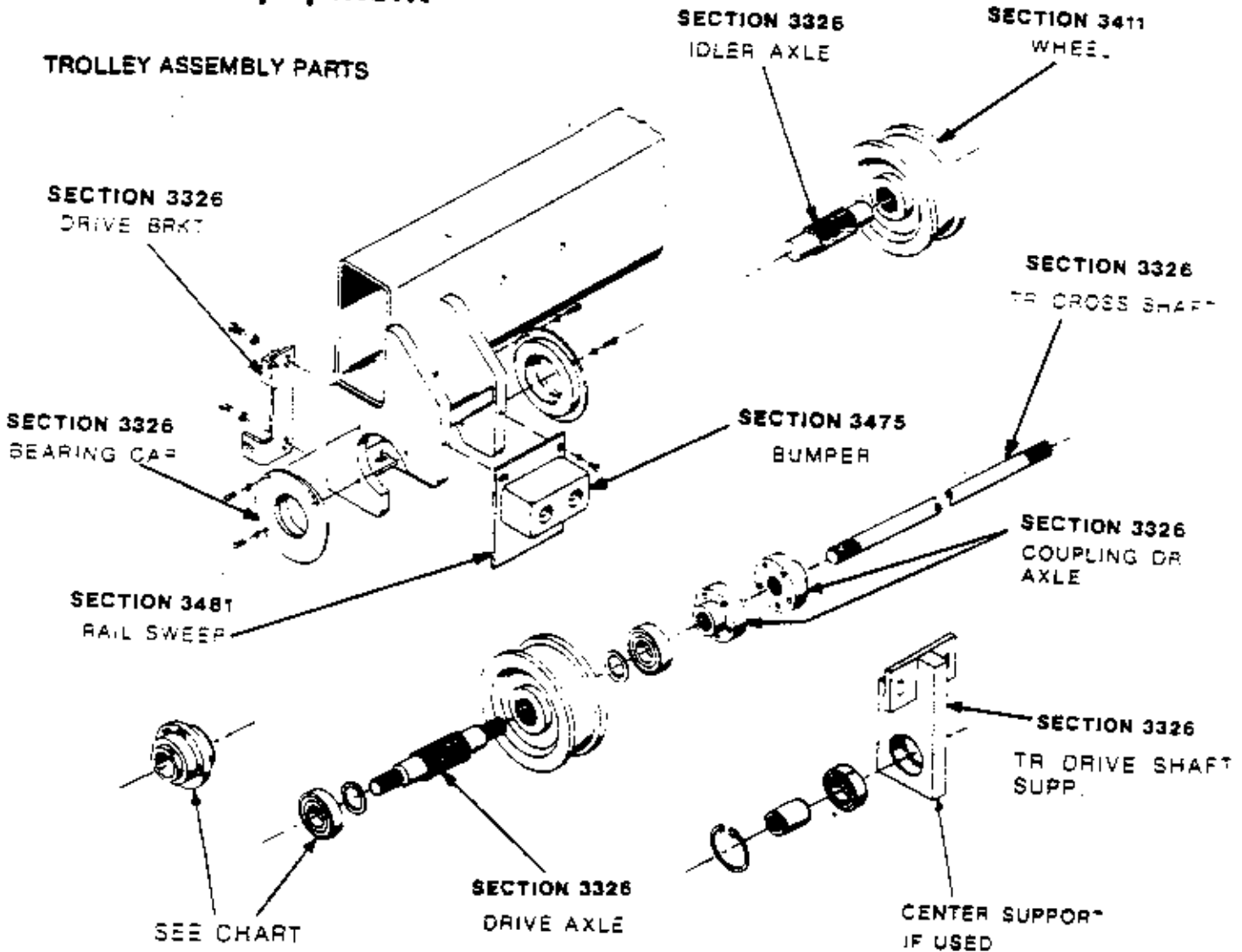

WHEEL SIZE	PART NUMBER		
	TR	TE	
	BEARING	PILOTED BRG	RETAINER RING
6"	N/A	6462204-06	0159164-00
8"	6471861-00	6459734-00	0624890-00
10"	6423461-00	6459734-00	0624890-00
12"	6474111-00	6459734-00	0624890-00

When Replacement Parts Are Needed, Order Only Yale<sup>®</sup> Factory Engineered Parts

FEBRUARY 1989

# Duff-Norton Yale® Hoists

SECTION 3326/3411

## TROLLEY ASSEMBLY PARTS

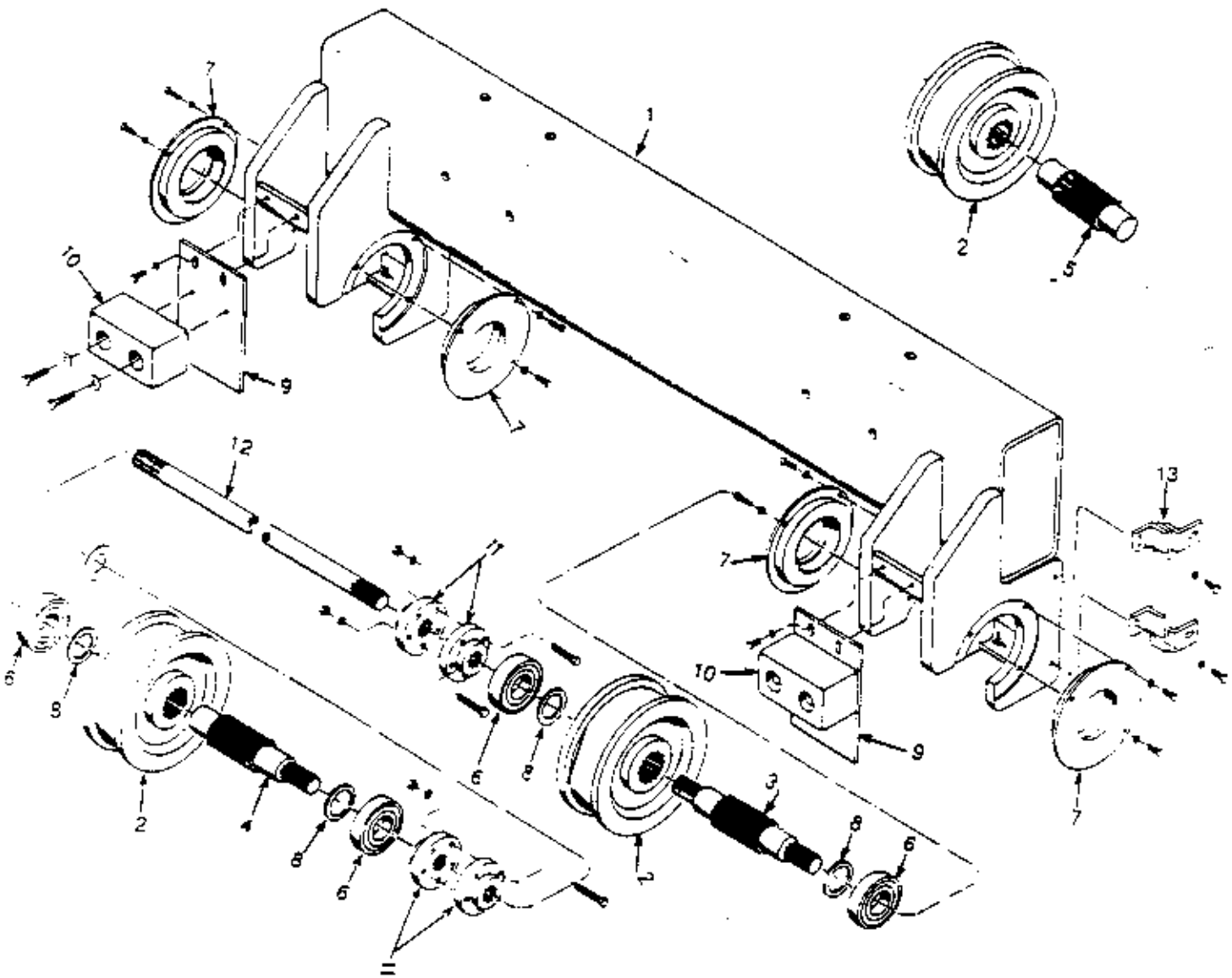

**When Replacement Parts Are Needed, Order Only Yale® Factory Engineered Parts**

DEC. 91

2

TR SERIES



**TROLLEY ASSEMBLY PARTS  
TR SERIES**

SECTION 3326/3410

ITEM	PART NO.	DESCRIPTION	QTY.
1	AS REQ'D.	WHEEL CARRIER	2
2	6472041-00	WHEEL 8 IN. 40 LB. MAX. RAIL	4
	6461293-00	BRONZE	4
	6463521-00	WHEEL 10 IN. 75 LB. MAX. RAIL	4
	6463561-00	BRONZE	4
	6490741-00	WHEEL 12 IN. 75 LB. MAX. RAIL	
	6491741-01	BRONZE	
	6474331-00	WHEEL 12 IN. 100 LB. MAX. RAIL	4
3	6472121-00	DRIVE AXLE 8 IN.	1
	6470171-00	DRIVE AXLE 10 IN.	1
	6474261-00	DRIVE AXLE 12 IN.	1
4	6472131-00	SHORT DRIVE AXLE 8 IN.	1
	6463481-00	SHORT DRIVE AXLE 10 IN.	1
	6474171-00	SHORT DRIVE AXLE 12 IN.	1
5	6472151-00	IDLER AXLE 8 IN.	1
	6463531-00	IDLER AXLE 10 IN.	2
	6474201-00	IDLER AXLE 12 IN.	2
6	6471861-00	WHEEL BEARING 8 IN.	2
	6423461-00	WHEEL BEARING 10 IN.	8
	6474111-00	WHEEL BEARING 12 IN.	8
7	6477651-00	BEARING CAP 8 IN.	8
	6477731-00	BEARING CAP 10 IN.	8
	6477641-00	BEARING CAP 12 IN.	8
8	6447913-04	WHEEL SPACER 8 IN. SHIM (NOT SHOWN)	8
	6431778-01	WHEEL SPACER 10 IN. SHIM (NOT SHOWN)	8
	6447913-05	WHEEL SPACER 12 IN. SHIM (NOT SHOWN)	8
9	6472171-00	RAIL SWEEP 8 IN. 40 LB. MAX. RAIL	4
	6471581-00	RAIL SWEEP 10 IN. 75 LB. MAX. RAIL	4
	6490591-00	RAIL SWEEP 12 IN. 75 LB. MAX. RAIL	4
	6474151-00	RAIL SWEEP 12 IN. 100 LB. MAX. RAIL	4
10	6424281-00	BUMPER	4
11	6490441-00	COUPLING	4
12	6421701-	CROSS SHAFT (AS REQ'D.)	4
13	6472161-00	DRIVE MTG. BRKT. 8 IN.	1
	6469481-00	DRIVE MTG. BRKT. 10 IN.	1
	6474091-00	DRIVE MTG. BRKT. 12 IN.	1
NS	6442582-00	CENTER SUPPORT KIT 8 IN. (AS REQ'D.)	1
	6442592-00	CENTER SUPPORT KIT 10 IN. (AS REQ'D.)	
	6442602-00	CENTER SUPPORT KIT 12 IN. (AS REQ'D.)	

When Replacement Parts Are Needed, Order Only Yale Factory Engineered Parts

DEC. 91

3

TR SERIES

EW / AW SERIES GT - GEARED TROLLEY  
4 7/8" & 6" TREAD DIAMETER WHEELS

**IMPORTANT**  
SELECT COMPONENT ASSEMBLY  
NUMBER FROM PARTS LIST IN FRONT  
COVER BEFORE SELECTING  
REPLACEMENT ITEM NUMBER

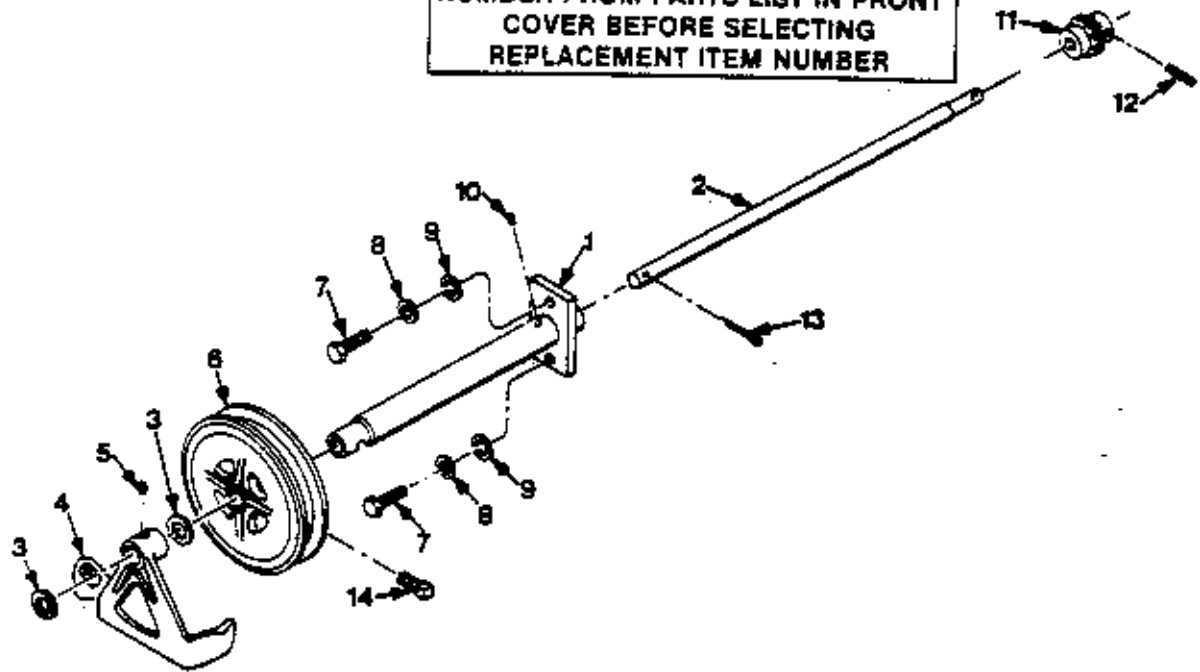

TABLE

4 7/8" TREAD DIAMETER WHEELS				
ASSEMBLY NUMBER	ITEM 1 EXTENSION	ITEM 2 SHAFT	ITEM 11 PINION	ITEM 12 ROLL PIN
6434722-01	0664454-00	6456491-01	0250202-00	0230207-00
6434722-02	6437154-00	6456491-02	↓	↓
6434722-03	6439061-00	6456491-03	↓	↓
6434722-04	6452881-01	6456491-04	↓	↓
6434722-05	6452881-02	6456491-05	↓	↓
6434722-06	6442576-00	6456491-06	↓	↓
6434722-07	6452881-03	6456491-07	0250202-00	0230207-00

6" TREAD DIAMETER WHEELS				
ASSEMBLY NUMBER	ITEM 1 EXTENSION	ITEM 2 SHAFT	ITEM 11 PINION	ITEM 12 ROLL PIN
6434732-01	0664454-00	0664456-00	0588168-00	0559292-00
6434732-02	6437154-00	6430283-00	↓	↓
6434732-03	6439061-00	6439051-00	↓	↓
6434732-04	6452881-01	6452891-01	↓	↓
6434732-05	6452881-02	6452881-02	↓	↓
6434732-06	6442576-00	6446733-00	↓	↓
6434732-07	6452881-03	6452891-03	0588168-00	0559292-00

ITEM NUMBER	PART NUMBER	DESCRIPTION	QTY
3	0250668-00	WASHER	2
4	0588165-00	GUIDE	1
5	0185584-00	FITTING	1
6	0111132-00	HANDWHEEL	1
7	0554850-00	1/2-13 X 1 1/4 HEX HEAD SCREW	2
8	0142209-00	WASHER	2
9	0150268-00	LOCKWASHER	2
10	0227845-00	FITTING	1
11	SEE TABLE	PINION	1
12	SEE TABLE	ROLL PIN	1
13	0381400-00	COTTER PIN	1
14	0388054-00	7/16-14X1 SQUARE HEAD SCREW	1
15	0033730-00	HAND CHAIN (NOT SHOWN) SPECIFY LENGTH	1

165-912-070

**When Replacement Parts Are Needed, Order Only Yale Factory Engineered Parts.**

SECTION 3330

TROLLEY HANDWHEEL GROUP

EW / AW SERIES GT - GEARED TROLLEY  
8 & 10" TREAD DIAMETER WHEELS

**IMPORTANT**  
SELECT COMPONENT ASSEMBLY  
NUMBER FROM PARTS LIST IN FRONT  
COVER BEFORE SELECTING  
REPLACEMENT ITEM NUMBER

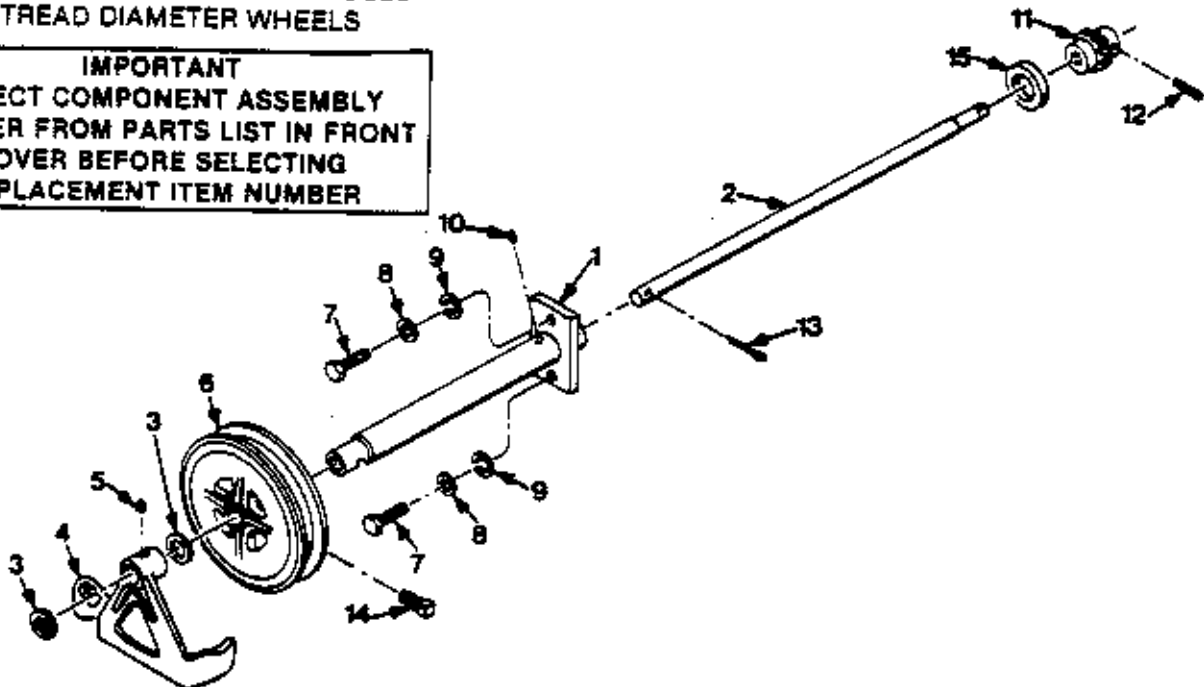

TABLE

ASSEMBLY NUMBER	ITEM 1 EXTENSION	ITEM 2 SHAFT	LIFT
6434742-01	6445804-01	8436753-00	2
6434742-02	0664820-00	0665191-00	3
6434742-03	6443384-00	6419981-06	4
6434742-04	6420554-00	6410351-00	5
6434742-05	6444194-01	6419981-03	6
6434742-06	6444194-02	6419981-04	7
			8

ITEM NUMBER	PART NUMBER	DESCRIPTION	QTY.
1	SEE TABLE	EXTENSION ITEM 1	1
2	SEE TABLE	SHAFT ITEM 2	1
3	0250664-00	WASHER	3
4	0591410-00	GUIDE	1
5	0185584-00	FITTING	1
6	0535795-00	HANDWHEEL	1
7	0596946-00	1/2-13 X 1 1/2 HEX HEAD SCREW	2
8	0142209-00	WASHER	2
9	0150266-00	LOCKWASHER	2
10	0227845-00	FITTING	1
11	0589890-00	PINION	1
12	0230236-00	ROLL PIN	1
13	0154214-00	COTTER PIN	1
14	0388010-00	1/2-13 SQUARE HEAD SCREW	1
15	0665193-00	SPACER	1
16	0033730-00	HAND CHAIN (NOT SHOWN) SPECIFY LENGTH	1

When Replacement Parts Are Needed, Order Only Yale Factory Engineered Parts. 165-912-073

JUNE 1983

EW / AW SERIES

## DOUBLE C FACE BRAKES

## TROLLEY MOTOR BRAKE

**Maintenance****Caution**

**BEFORE ATTEMPTING TO SERVICE OR REPAIR, MAKE CERTAIN THAT POWER IS DISCONNECTED AND LOAD IS REMOVED OR BLOCKED TO PREVENT INJURY OR PROPERTY DAMAGE.**

**Brake Installation**

**IMPORTANT:** Brake should be properly adjusted according to service portion of parts manual at this time. Hub should be installed in brake to align disc. Do not operate manual release or energize brake coil before installation in order to preserve alignment of rotating disc for ease of installation.

**Manual Release**

To manually release the brake, turn the release knob (15) clockwise to STOP position to release the brake. The brake will remain released until the knob is turned counterclockwise approximately 65, or until the brake coil is energized, automatically resetting the brake.

**Wear Adjustment**

Before air gap (A) reaches .100", adjustment is required. Any delay in adjusting the magnet air gap will result in eventual loss of torque.

To adjust, remove cover (9) to expose adjusting screws (25M) and magnet air gap (A). Turn two square head setscrews (25M) until air gap (A) measures .045/.050 for 1 disc models, .050/.055 for 2 disc models and .060/.065 for 3 disc models. Air gap should be the same on both sides.

**Torque Adjustment**

The magnetic disc brake is factory set for rated static torque. The brake can be adjusted to reduce torque which increases stopping time. Do not attempt to adjust brake for a higher torque, as this will cause premature coil burnout.

To adjust, remove cover (9) to expose torque locknuts (25U), which are above torque spring (25G). To increase stopping time and reduce torque, turn two lock nuts (25U) counterclockwise, increasing spring length. Each full turn reduces torque 7% to 10%.

**Friction Disc Replacement**

When total wear on a rotating friction disc (10) reaches 1/16", replace disc.

To replace friction disc, remove adapter housing (7) which includes snail (8) by removing nuts (30) and lockwasher (29). Remove operator assembly (25) by removing screws (11) and pivot stud (19). Item (19) has a hex socket in the end of stud for removal.

**NOTE:** Do not loosen nuts (6) on pivot stud (19), or pivot stud adjustment to quite the brake will have to be made.

Remove worn rotating disc (10) and stationary disc (2). Install new disc in the same order. Install stabilizer clip (23), if furnished on rotating disc prior to installing.

**Re-assembly of Operator Assembly**

Turn two screws (25M) counterclockwise five turns. Place operator assembly onto brake bracket (1) and install two screws (11). Replace compression spring (3), bushing (5), washer (4) and pivot stud (19) which has the two nuts (6) in place. Tighten firmly.

Readjust magnet air gap (A) as described under "Wear Adjustment". Check manual release operation before completing installation. Adjust per manual release adjustment if required.

**Magnet Assembly Replacement**

Remove adapter assembly as described under friction disc replacement. Remove two capscrews (25D), wire clamps (25E), magnet assembly (25A) and shock mount (25C).

Replace shock mount and magnet, feeding coil wires through hole in back of bracket (25B). Tighten mounting screws with 55 to 60 lbs. in. torque. Reassemble as described under friction disc replacement.

**Manual Release Adjustment**

To adjust, remove adapter housing (7) and adjust air gap (A). If brake does not release, turn adjusting screw (17) counterclockwise 1/4 turn and try again. If the release knob (15) does not return to normal position automatically, turn screw (17) clockwise 1/4 turn and try again. Keep repeating until the release works properly.

It is important that the release knob returns to its normal position automatically when power is applied to the magnet.

**NOTE:** For end mounted brakes, see Section 1351.

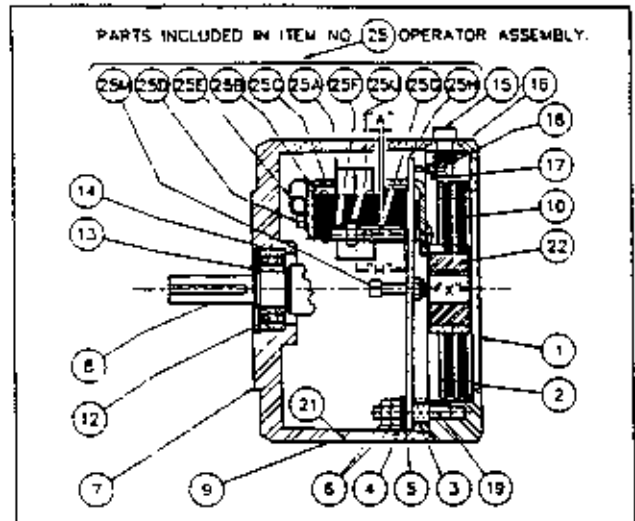
**YALE INTERNATIONAL INC.****Yale® Hoists**

3105 N. Washington  
P.O. Box 1000  
Forrest City, AR 72335  
Phone 800-999-6318 Fax 800-766-0223

**When Replacement Parts Are Needed, Order Only Yale Factory Engineered Parts**

REVISED October 1996

DINGS 60 SERIES  
REPLACEMENT PARTS ILLUSTRATION

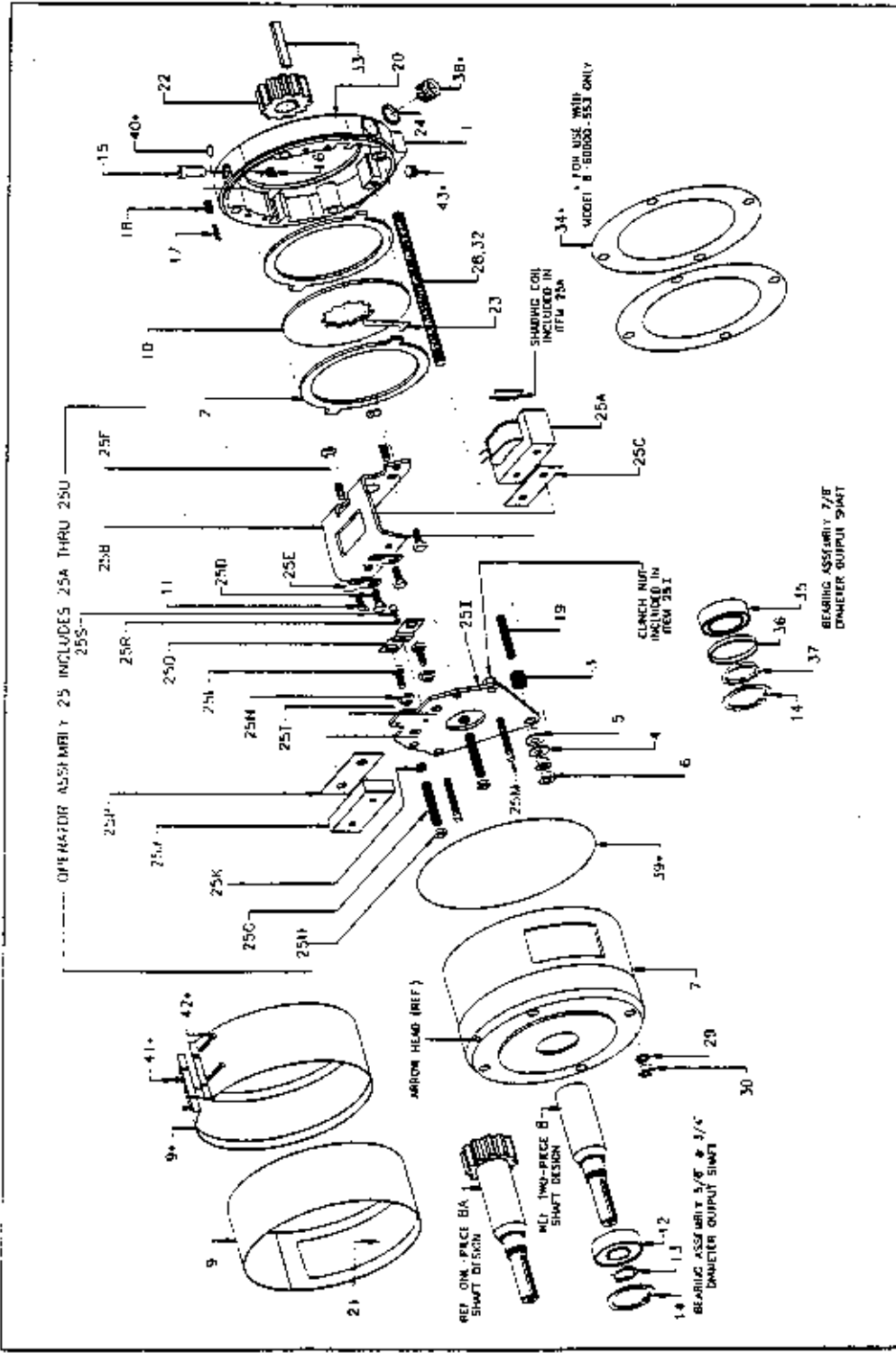

Wiring Diagrams

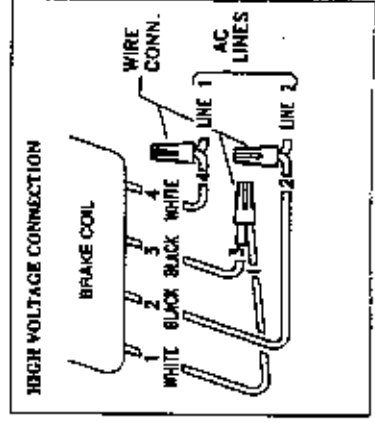
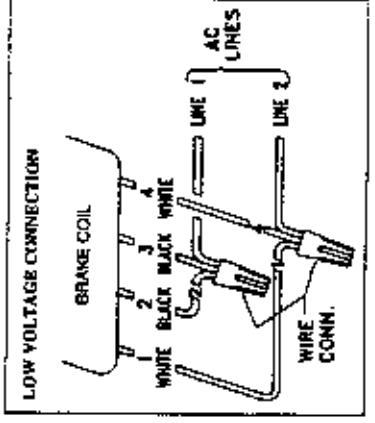

NOTE: For End-Mounted Brakes  
see Section 1351.

**DING'S 60 SERIES BRAKE****SECTION 3351  
REPAIR PARTS**

ITEM NO.	DESCRIPTION	QTY
1	Bracket 1 & 2 disc	1
1	Bracket 3 disc	1
2	Stationary disc	*
3	Compression spring for all except 20 lb. ft.	1
3	Compression spring, 20 lb. ft.	1
4	Plain brass washer	1
5	Nylon bushing	1
6	Hex nut 5/16-18 thread	2
7	Adapter housing	1
8	Two-piece shaft design	1
8A	One-piece shaft hub design	1
9	Wrap-around cover	1
10	Splined rotating friction disc	*
11	Hex. Hd. capscrew 1/4-20 x 1/2 Lg.	2
12	Double seal ball bearing, 5/8 or 3/4 output shaft	1
13	Truarc retaining ring, 5/8 or 3/4 output shaft	1
14	Truarc retaining ring, all models	1
15	Release knob	1
16	Release return spring	1
17	Release adjustment screw	1
18	Release adjustment lock spring	1
19	Pivot stud	1
20	Nameplate	1
21	Instruction label, 2-piece shaft design	1
21	Instruction label, 1-piece shaft design	1
22	Splined hub for use with item 8	1
23	Stabilizer clip, rotating friction disc	*
24	Wire outlet cap plug	1
25	Operator assembly: includes "A" through "U" (not shown as an assem.)	1
25A	Magnet assembly	1
25B	Magnet mounting bracket	1
25C	Magnet shock mount	1
25D	Hex. Hd. capscrew 1/4-20 x 5/8 Lg. Grade 5	2
25E	Cable clamp	2
25F	Carriage bolts 1/4-20	2

ITEM NO.	DESCRIPTION	QTY
25G	Torque spring (blue) 1.5 lb. ft.	2
25G	Torque spring (silver) 3 & 6 lb. ft.	2
25G	Torque spring (bronze) 10 & 15 lb. ft.	2
25G	Torque spring (green) 20 lb. ft.	2
25H	Armature plate assembly: includes "I" through "T" (not shown as an assem.)	1
25I	Armature plate	1
25J	Armature lamination assembly	1
25K	Nyliner bushing	2
25L	Hex. Hd. capscrew 1/4-20 x 5/8 Lg.	2
25M	Wear adjustment screw sq. hd. 1/4-20 x 1-1/2" Lg.	2
25N	Armature spacer	2
25P	Armature shock mount	1
25Q	Locking plate	1
25R	Split spring lockwasher #8	1
25S	Soc. Hd. capscrew #8-32 x 1/4" Lg.	1
25T	Roll pin 5/32" dia. x 3/8" Lg.	1
25U	Locknut 1/4-20	2
28	Mounting stud, 3/8-16 x 6-7/16 Lg. 1 & 2 disc only	4
29	3/8 split spring lockwasher	4
30	Hex nut 3/8-16	4
32	Mounting stud 3/8-16 x 6-13/16 Lg.	1
33	Key 3/16 square x 1-13/16 Lg.	4
34	Mounting face gasket	1
35	Double seal ball bearing, 7/8 output shaft	2
36	Bearing spacer	1
37	Truarc retaining ring, 7/8 output shaft	1
38	Pipe Plug 1/2"	1
39	"O" ring adapter, housing to bracket	1
40	"O" ring release rod #010	1
41	Rd. Hd. screws #10/32 x 1-1/4 long	1
42	Locknut #10-32	2
43	1/8" hex. soc. pipe plug	2

\* Number of rotating discs is shown in the brake model number. Example - 6-62006-551 has two rotating discs. The number of stationary discs is one more than the number of rotating discs.

\*\* Part number is determined by one or more of the following: model number, voltage, motor shaft diameter and keyway size.

**WHEN REPLACEMENT PARTS ARE NEEDED, ORDER ONLY YALE FACTORY ENGINEERED PARTS  
REVISED OCTOBER 1996**

# Yale Hoisting Equipment

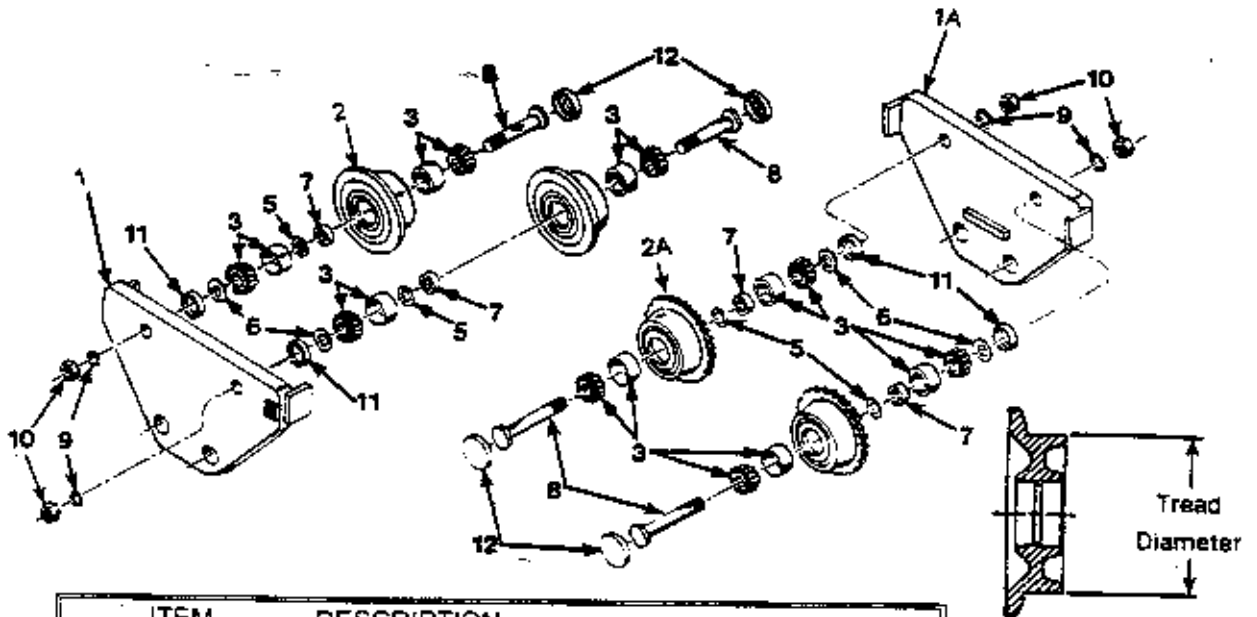

ITEM	DESCRIPTION
1	SIDEPLATE PLAIN
1A	SIDEPLATE GEARED
2	WHEEL PLAIN
2A	WHEEL GEARED
3	BEARING
4	AXLE GROUP INC. ITEMS 3,5,6,7,8,9,10,11,12
5	BEARING SHIM
6	BEARING SPACER
7	WHEEL SPACER
8	AXLE
9	LOCKWASHER
10	AXLE NUT
11	DUST COVER INSIDE (8 & 10 IN TD ONLY)
12	DUST COVER OUTSIDE (8 & 10 IN TD ONLY)

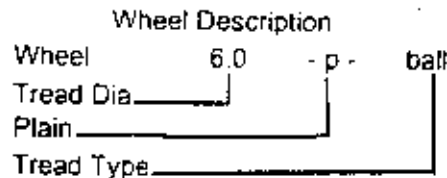

**NOTE:** THE TROLLEY ILLUSTRATED ABOVE MAY NOT EXACTLY REPRESENT THE ACTUAL APPEARANCE OF YOUR TROLLEY HOWEVER, IT IS TYPICAL.

**NOTE:** FOR REPAIR PARTS, REFER TO PARTS LIST IN FRONT OF THE PARTS MANUAL.

When Replacement Parts Are Needed, Order Only Yale<sup>®</sup> Factory Engineered Parts.

**SECTION 3475  
TROLLEY GUIDE ROLLER**

**IMPORTANT  
SELECT COMPONENT ASSEMBLY  
NUMBER FROM PARTS LIST  
BEFORE SELECTING  
REPLACEMENT ITEM NUMBER**

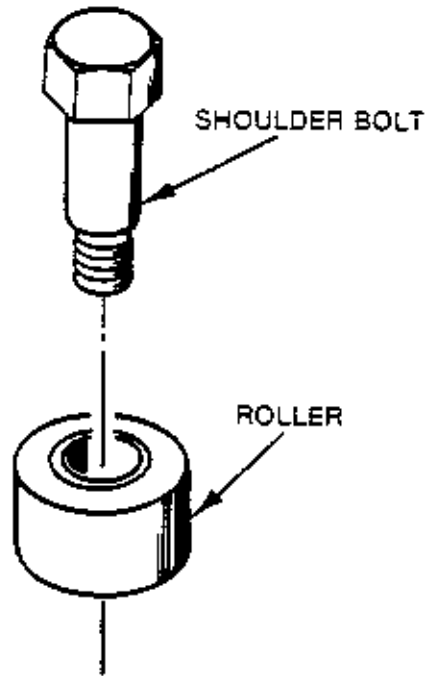

COMPONENT NUMBER	ROLLER DIAMETER	MATERIAL	ROLLER PART NUMBER	SHOULDER BOLT PART NO.
6446012-01	2	STANDARD	6481681-01	6481371-00
6446012-02	1 3/4	STANDARD	6481681-02	6481371-00
6452562-01	2	BRONZE	6491571-01	6481371-00
6452562-02	1 3/4	BRONZE	6491571-02	6481371-00

FORM NO. 185-912-116

**When Replacement Parts Are Needed, Order Only Yale® Factory Engineered Parts**

JULY 1983

EW SERIES



# POWERED HOIST INSPECTION CHECK LIST

SEE PREVENTIVE MAINTENANCE SECTION OF INSTRUCTION MANUAL FOR DETAILS.

CHECK ONLY COMPONENTS APPLICABLE FOR SPECIFIC EQUIPMENT AND INSPECTION TYPE.

HOIST MODEL \_\_\_\_\_

HOIST S/N \_\_\_\_\_

HOOKS		YES	NO	CABLE		YES	NO	CHAINS		YES	NO
HARDWARE LOOSE	<input type="checkbox"/>	<input type="checkbox"/>	BROKEN WIRES AT ENDS	<input type="checkbox"/>	<input type="checkbox"/>	BINDING	<input type="checkbox"/>	<input type="checkbox"/>	<input type="checkbox"/>	<input type="checkbox"/>	
CRACKS	<input type="checkbox"/>	<input type="checkbox"/>	BROKEN WIRES EXCESSIVE	<input type="checkbox"/>	<input type="checkbox"/>	CRACKED	<input type="checkbox"/>	<input type="checkbox"/>	<input type="checkbox"/>	<input type="checkbox"/>	
EXCESSIVE WEAR	<input type="checkbox"/>	<input type="checkbox"/>	EXCESSIVE WEAR	<input type="checkbox"/>	<input type="checkbox"/>	TWISTED	<input type="checkbox"/>	<input type="checkbox"/>	<input type="checkbox"/>	<input type="checkbox"/>	
BENT	<input type="checkbox"/>	<input type="checkbox"/>	KINKED OR DISTORTED	<input type="checkbox"/>	<input type="checkbox"/>	DISTORTED	<input type="checkbox"/>	<input type="checkbox"/>	<input type="checkbox"/>	<input type="checkbox"/>	
SPREADING	<input type="checkbox"/>	<input type="checkbox"/>	CORROSION	<input type="checkbox"/>	<input type="checkbox"/>	CORRODED	<input type="checkbox"/>	<input type="checkbox"/>	<input type="checkbox"/>	<input type="checkbox"/>	
FREELY ROTATE	<input type="checkbox"/>	<input type="checkbox"/>	HEAT DAMAGED	<input type="checkbox"/>	<input type="checkbox"/>	EXCESSIVE WEAR	<input type="checkbox"/>	<input type="checkbox"/>	<input type="checkbox"/>	<input type="checkbox"/>	
LATCH DAMAGED	<input type="checkbox"/>	<input type="checkbox"/>				WORN CHAIN GUIDES	<input type="checkbox"/>	<input type="checkbox"/>	<input type="checkbox"/>	<input type="checkbox"/>	
						POCKET WHEELS WORN	<input type="checkbox"/>	<input type="checkbox"/>	<input type="checkbox"/>	<input type="checkbox"/>	
BRAKES		YES	NO	WIRING		YES	NO	DRUM & SHEAVES		YES	NO
MOTOR BRAKE WORN OR NOT OPERATING	<input type="checkbox"/>	<input type="checkbox"/>	LOOSE CONNECTIONS	<input type="checkbox"/>	<input type="checkbox"/>	WORN EXCESSIVELY	<input type="checkbox"/>	<input type="checkbox"/>	<input type="checkbox"/>	<input type="checkbox"/>	
EXCESSIVE LOADBRAKE DRIFT OR BLACKLASH	<input type="checkbox"/>	<input type="checkbox"/>	FRAYED	<input type="checkbox"/>	<input type="checkbox"/>	CRACKED OR SCORED	<input type="checkbox"/>	<input type="checkbox"/>	<input type="checkbox"/>	<input type="checkbox"/>	
EXCESSIVE DISC WEAR	<input type="checkbox"/>	<input type="checkbox"/>	DAMAGED	<input type="checkbox"/>	<input type="checkbox"/>						
			PROPER GROUNDING	<input type="checkbox"/>	<input type="checkbox"/>						
LIMIT SWITCHES		YES	NO	LOAD LIMITING DEVICE		YES	NO	COLLECTORS		YES	NO
OPERATING PROPERLY	<input type="checkbox"/>	<input type="checkbox"/>	OPERATING PROPERLY	<input type="checkbox"/>	<input type="checkbox"/>	BINDING	<input type="checkbox"/>	<input type="checkbox"/>	<input type="checkbox"/>	<input type="checkbox"/>	
						EXCESSIVE WEAR	<input type="checkbox"/>	<input type="checkbox"/>	<input type="checkbox"/>	<input type="checkbox"/>	
HOUSING		YES	NO	OPERATION CONTROLS		YES	NO	LUBRICATION		YES	NO
DISTORTED	<input type="checkbox"/>	<input type="checkbox"/>	CONTACTOR PITTING	<input type="checkbox"/>	<input type="checkbox"/>	ALL POINTS LUBRICATED AS GIVEN IN LUB CHART	<input type="checkbox"/>	<input type="checkbox"/>	<input type="checkbox"/>	<input type="checkbox"/>	
CRACKS	<input type="checkbox"/>	<input type="checkbox"/>	OPERATING PROPERLY	<input type="checkbox"/>	<input type="checkbox"/>	OIL DARK OR LOW	<input type="checkbox"/>	<input type="checkbox"/>	<input type="checkbox"/>	<input type="checkbox"/>	
LOOSE HARDWARE	<input type="checkbox"/>	<input type="checkbox"/>	DAMAGED PUSH BUTTON	<input type="checkbox"/>	<input type="checkbox"/>	OIL LEAKS	<input type="checkbox"/>	<input type="checkbox"/>	<input type="checkbox"/>	<input type="checkbox"/>	
BEARING NOISE	<input type="checkbox"/>	<input type="checkbox"/>	HOUSING	<input type="checkbox"/>	<input type="checkbox"/>						
SUPPORTING STRUCTURE		YES	NO	AIR SYSTEM		YES	NO	WARNING LABELS		YES	NO
CONTINUED ABILITY TO SUPPORT IMPOSED LOADS	<input type="checkbox"/>	<input type="checkbox"/>	LEAKING	<input type="checkbox"/>	<input type="checkbox"/>	MISSING	<input type="checkbox"/>	<input type="checkbox"/>	<input type="checkbox"/>	<input type="checkbox"/>	
WORN OR DISTORTED TROLLEY PARTS	<input type="checkbox"/>	<input type="checkbox"/>	LOOSE CONNECTIONS	<input type="checkbox"/>	<input type="checkbox"/>	ILLEGIBLE	<input type="checkbox"/>	<input type="checkbox"/>	<input type="checkbox"/>	<input type="checkbox"/>	
			BROKEN CONTROL PENDANT	<input type="checkbox"/>	<input type="checkbox"/>						

NOTE IF ANY (X) IS CHECKED DO NOT OPERATE THE HOIST UNTIL REPAIRS HAVE BEEN MADE.

REMARKS AND REPAIRS MADE \_\_\_\_\_  
 \_\_\_\_\_  
 \_\_\_\_\_  
 \_\_\_\_\_  
 \_\_\_\_\_  
 \_\_\_\_\_  
 \_\_\_\_\_  
 \_\_\_\_\_

SIGNATURE \_\_\_\_\_ DATE \_\_\_\_\_ CLOCK NUMBER \_\_\_\_\_

POWERED HOIST INSPECTION CHECK LIST

SEE PREVENTIVE MAINTENANCE SECTION OF INSTRUCTION MANUAL FOR DETAILS.

CHECK ONLY COMPONENTS APPLICABLE FOR SPECIFIC EQUIPMENT AND INSPECTION TYPE.

HOIST MODEL \_\_\_\_\_

HOIST S/N \_\_\_\_\_

HOOKS		YES	NO	CABLE		YES	NO	CHAINS		YES	NO
HARDWARE LOOSE	<input type="checkbox"/>	<input type="checkbox"/>	<input type="checkbox"/>	BROKEN WIRES AT ENDS	<input type="checkbox"/>	<input type="checkbox"/>	<input type="checkbox"/>	BINDING	<input type="checkbox"/>	<input type="checkbox"/>	<input type="checkbox"/>
CRACKS	<input type="checkbox"/>	<input type="checkbox"/>	<input type="checkbox"/>	BROKEN WIRES EXCESSIVE	<input type="checkbox"/>	<input type="checkbox"/>	<input type="checkbox"/>	CRACKED	<input type="checkbox"/>	<input type="checkbox"/>	<input type="checkbox"/>
EXCESSIVE WEAR	<input type="checkbox"/>	<input type="checkbox"/>	<input type="checkbox"/>	EXCESSIVE WEAR	<input type="checkbox"/>	<input type="checkbox"/>	<input type="checkbox"/>	TWISTED	<input type="checkbox"/>	<input type="checkbox"/>	<input type="checkbox"/>
BENT	<input type="checkbox"/>	<input type="checkbox"/>	<input type="checkbox"/>	KINKED OR DISTORTED	<input type="checkbox"/>	<input type="checkbox"/>	<input type="checkbox"/>	DISTORTED	<input type="checkbox"/>	<input type="checkbox"/>	<input type="checkbox"/>
SPREADING	<input type="checkbox"/>	<input type="checkbox"/>	<input type="checkbox"/>	CORROSION	<input type="checkbox"/>	<input type="checkbox"/>	<input type="checkbox"/>	CORRODED	<input type="checkbox"/>	<input type="checkbox"/>	<input type="checkbox"/>
FREELY ROTATE	<input type="checkbox"/>	<input type="checkbox"/>	<input type="checkbox"/>	HEAT DAMAGED	<input type="checkbox"/>	<input type="checkbox"/>	<input type="checkbox"/>	EXCESSIVE WEAR	<input type="checkbox"/>	<input type="checkbox"/>	<input type="checkbox"/>
LATCH DAMAGED	<input type="checkbox"/>	<input type="checkbox"/>	<input type="checkbox"/>					WORN CHAIN GUIDES	<input type="checkbox"/>	<input type="checkbox"/>	<input type="checkbox"/>
								POCKET WHEELS WORN	<input type="checkbox"/>	<input type="checkbox"/>	<input type="checkbox"/>
BRAKES		YES	NO	WIRING		YES	NO	DRUM & SHEAVES		YES	NO
MOTOR BRAKE WORN OR NOT OPERATING	<input type="checkbox"/>	<input type="checkbox"/>	<input type="checkbox"/>	LOOSE CONNECTIONS	<input type="checkbox"/>	<input type="checkbox"/>	<input type="checkbox"/>	WORN EXCESSIVELY	<input type="checkbox"/>	<input type="checkbox"/>	<input type="checkbox"/>
EXCESSIVE LOADBRAKE DRIFT OR BLACKLASH	<input type="checkbox"/>	<input type="checkbox"/>	<input type="checkbox"/>	FRAYED	<input type="checkbox"/>	<input type="checkbox"/>	<input type="checkbox"/>	CRACKED OR SCORED	<input type="checkbox"/>	<input type="checkbox"/>	<input type="checkbox"/>
EXCESSIVE DISC WEAR	<input type="checkbox"/>	<input type="checkbox"/>	<input type="checkbox"/>	DAMAGED	<input type="checkbox"/>	<input type="checkbox"/>	<input type="checkbox"/>				
				PROPER GROUNDING	<input type="checkbox"/>	<input type="checkbox"/>	<input type="checkbox"/>				
LIMIT SWITCHES		YES	NO	LOAD LIMITING DEVICE		YES	NO	COLLECTORS		YES	NO
OPERATING PROPERLY	<input type="checkbox"/>	<input type="checkbox"/>	<input type="checkbox"/>	OPERATING PROPERLY	<input type="checkbox"/>	<input type="checkbox"/>	<input type="checkbox"/>	BINDING	<input type="checkbox"/>	<input type="checkbox"/>	<input type="checkbox"/>
								EXCESSIVE WEAR	<input type="checkbox"/>	<input type="checkbox"/>	<input type="checkbox"/>
HOUSING		YES	NO	OPERATION CONTROLS		YES	NO	LUBRICATION		YES	NO
DISTORTED	<input type="checkbox"/>	<input type="checkbox"/>	<input type="checkbox"/>	CONTACTOR PITTING	<input type="checkbox"/>	<input type="checkbox"/>	<input type="checkbox"/>	ALL POINTS LUBRICATED AS GIVEN IN LUB CHART	<input type="checkbox"/>	<input type="checkbox"/>	<input type="checkbox"/>
CRACKS	<input type="checkbox"/>	<input type="checkbox"/>	<input type="checkbox"/>	OPERATING PROPERLY	<input type="checkbox"/>	<input type="checkbox"/>	<input type="checkbox"/>	OIL DARK OR LOW	<input type="checkbox"/>	<input type="checkbox"/>	<input type="checkbox"/>
LOOSE HARDWARE	<input type="checkbox"/>	<input type="checkbox"/>	<input type="checkbox"/>	DAMAGED PUSH BUTTON	<input type="checkbox"/>	<input type="checkbox"/>	<input type="checkbox"/>	OIL LEAKS	<input type="checkbox"/>	<input type="checkbox"/>	<input type="checkbox"/>
BEARING NOISE	<input type="checkbox"/>	<input type="checkbox"/>	<input type="checkbox"/>	HOUSING	<input type="checkbox"/>	<input type="checkbox"/>	<input type="checkbox"/>				
SUPPORTING STRUCTURE		YES	NO	AIR SYSTEM		YES	NO	WARNING LABELS		YES	NO
CONTINUED ABILITY TO SUPPORT IMPOSED LOADS	<input type="checkbox"/>	<input type="checkbox"/>	<input type="checkbox"/>	LEAKING	<input type="checkbox"/>	<input type="checkbox"/>	<input type="checkbox"/>	MISSING	<input type="checkbox"/>	<input type="checkbox"/>	<input type="checkbox"/>
WORN OR DISTORTED TROLLEY PARTS	<input type="checkbox"/>	<input type="checkbox"/>	<input type="checkbox"/>	LOOSE CONNECTIONS	<input type="checkbox"/>	<input type="checkbox"/>	<input type="checkbox"/>	ILLEGIBLE	<input type="checkbox"/>	<input type="checkbox"/>	<input type="checkbox"/>
				BROKEN CONTROL PENDANT	<input type="checkbox"/>	<input type="checkbox"/>	<input type="checkbox"/>				

NOTE: IF ANY ( ) IS CHECKED DO NOT OPERATE THE HOIST UNTIL REPAIRS HAVE BEEN MADE.

REMARKS AND REPAIRS MADE \_\_\_\_\_  
 \_\_\_\_\_  
 \_\_\_\_\_  
 \_\_\_\_\_  
 \_\_\_\_\_  
 \_\_\_\_\_  
 \_\_\_\_\_  
 \_\_\_\_\_

SIGNATURE \_\_\_\_\_ DATE \_\_\_\_\_ CLOCK NUMBER \_\_\_\_\_